

***apC/8X***

---

**Technical Manual**

C●CURE®, and apC® are registered trademarks of Sensormatic Access Control Division (ACD).

Document Number: UM-010-C

Print Date: A p r i l , 2001

This manual is proprietary information of Sensormatic ACD. Unauthorized reproduction of any portion of this manual is prohibited. The material in this manual is for informational purposes only. It is subject to change without notice. Software House assumes no responsibility for incorrect information this manual may contain.

© 1997-2000 by Sensormatic ACD

70 Westview Street

Lexington, MA 02421-3108

All rights reserved.

# Table of Contents

## Before You Begin

Installation Overview . . . . .	x
How to Use this Manual . . . . .	xi
UL Listing . . . . .	xiii
FCC Class A Digital Device Limitations . . . . .	xiii
FCC Class B Notes . . . . .	xiii
Canadian Radio Emissions Requirements . . . . .	xiv
CE Compliance . . . . .	xv
Conventions . . . . .	xv
Important Safety Information . . . . .	xv

## Chapter 1

### Overview

apC/8X Basics . . . . .	1-2
Software-Controlled Options	1-2
apC/8X Optional Modules	1-2
Battery Backup	1-5
Card Readers . . . . .	1-6
Magnetic Stripe Readers	1-6
Wiegand Readers	1-6

The Auxiliary Relay Module 1-7

Paired Readers 1-7

## **Chapter 2 apC/8X Physical Requirements**

External Devices and the apC/8X.....	2-2
Equipment Wiring Requirements .....	2-4
Cabling 2-7	
apC/8X Event and Card Storage.....	2-8
Calculating apC/8X Memory Requirements 2-9	
apC/8X Power Supply Limitations.....	2-11
Power Supply Limits 2-12	
Connecting the apC/8X to a Host .....	2-14
Configuring apC/8X Jumpers 2-15	
RS-232C Connection 2-15	
RS-485 Connection 2-16	
RS-232C to RS-485 Converter 2-16	
Line Drivers for directly connected apC/8Xs 2-17	
Modems for dialup mode apC/8Xs 2-18	
Replacing the apC/8X EPROMs .....	2-19

## **Chapter 3 Identifying Hardware and Mounting the apC/8X**

apC/8X Hardware Components .....	3-2
Mounting the apC/8X Cabinet .....	3-3
Connecting the apC/8X Input Voltage.....	3-5
Connecting a Power Failure Input .....	3-5
Connecting the Advanced Power System (apS) .....	3-5

## **Chapter 4 Wiring Card Readers**

Card Reader Configurations .....	4-2
Wiring Configurations 4-4	
Reader Wiring Configurations .....	4-9
Setting Up a Reader .....	4-15

	Setting Reader Type for an RM-4 Personality Module	4-15
	Setting the Reader Address for RM-4 Personality Modules	4-17
	Installing the Auxiliary Relay Module (ARM-1)	4-18
	Wiring for Relay Outputs	4-22
	Determining the Relay Locations for RM Readers	4-24
	Wiring Inputs to the RM	4-25
	RM-4 Personality Module with Third Party Reader	4-30
	The RM-4 Personality Module	4-30
	Installing the RM1 or RM2 Reader Assembly	4-33
	Installing the RM-4 Personality Module	4-35
	Optional Heater Kit	4-36
<b>Chapter 5</b>	<b>Input and Output Modules</b>	
	Overview	5-2
	Installing the Star or Mini Star Couplers	5-3
	Installing the Wiegand/Proximity Star Coupler (WPSC)	5-5
	Installing the apC-I/32 Supervised Input Module	5-7
	Removing a Supervised Input module	5-10
	Installing the apC-R/48 Relay Module	5-11
	Setting Up Relays	5-14
	R/48 Relays	5-15
	The RM Optional Modules	5-19
	I8 Input Module	5-19
	apC-R8 Output Bus Module	5-21
	Installing Optional Modules	5-22
	Output Board Installation	5-25
	Setting Up RM Module Addresses	5-27
<b>Chapter 6</b>	<b>apC/8X Panel Setup</b>	
	Setting Up the Main Panel	6-2

	Setting the apC/8X Switches	6-4
	Setting the apC/8X Jumpers . . . . .	6-14
	apC/8X LEDs . . . . .	6-17
	Communications LEDs	6-18
	LED Bar	6-20
	LED on the apC/8X cabinet	6-21
<b>Chapter 7</b>	<b>Testing the apC/8X Installation</b>	
	Testing Readers . . . . .	7-2
	Magnetic Stripe Readers	7-2
	RM LEDs	7-4
	Non-Sensormatic Readers	7-5
	Testing the apC/8X Main Circuit Board . . . . .	7-5
	The apCTest Program . . . . .	7-6
<b>Appendix A</b>	<b>Equipment Specifications</b>	
	Operating Environment . . . . .	A-2
	Equipment Dimensions and Weights . . . . .	A-3
	RM Series Card Reader Configurations . . . . .	A-5
	Environmental Specifications	A-6
<b>Appendix B</b>	<b>Calculating Maximum Wiring Lengths</b>	
	Using the Worksheet . . . . .	B-3
	Sample Calculation Using the Worksheet	B-5
<b>Appendix C</b>	<b>Packing and Shipping the apC/8X</b>	
<b>Appendix D</b>	<b>Modem Settings</b>	
	Dialup Modem Settings . . . . .	D-1
	Configuring Modems for Use with Dialup Line Configuration	D-3
	Configuring Modems for Use with Leased Line Configuration	D-4
	OEM HyperTerminal Edits for 4-Wire Leased Lines	D-7
	Panel to Modem Connection Diagram	D-9

	OEM to Host Computer Cable Connection	D-9
	Configuring Modems with Software	D-9
<b>Appendix E</b>	<b>Templates and Technical Drawings</b>	
<b>Appendix F</b>	<b>System Specific Information</b>	
	apC/8X Input/Output Specifications	F-2
	apC/8X Number System Specifications	F-8
	Setting Software Switches	F-15
	C•CURE 1 Plus Ultra	F-15
<b>Index</b>		





# Before You Begin

This *apC/8X Technical Manual* is for experienced technicians who need to install or configure the apC/8X hardware. This manual describes the following procedures.

- Configuring and installing card readers
- Installing the apC/8X and optional modules
- Wiring equipment to the apC/8X
- Setting apC/8X switches
- Testing the installation

The manual assumes that you are familiar with the apC/8X and its operation. This introduction provides the following information:

- A description of the individual chapters in this manual
- A guide to where you can find additional information about the apC/8X
- A list of the conventions used in this manual

## Installation Overview

While you do not have to perform apC/8X installation in any particular order, the following checklist gives a logical order for the steps necessary to install your apC/8X.

- Check the apC/8X physical requirements (Chapter 2)
- Check the apC/8X hardware to make sure nothing is missing (Chapter 3)
- Check the dimensions for mounting the apC/8X with the cabinet and mounted the apC/8X (Chapter 3)
- Wire the readers and optional equipment to the apC/8X (Chapter 4)
- Configure any input and output boards (Chapter 5)
- Set up the apC/8X panel (Chapter 6)
- Tested your installation (Chapter 7)



### **IMPORTANT**

Before handling and installing any component, follow these precautions:

- Discharge your body's static electricity charge by touching a grounded surface.
- Wear a grounding strap and work on a grounded static protection mat.
- Do not slide a component over any surface.
- Limit your movements during the installing process to reduce static electricity.

# How to Use this Manual

This manual has seven chapters and six appendices. Turn to the chapter or appendix in this manual that contains the information you need.

## **Chapter 1: Overview**

Gives an overview of the apC/8X panel and explains the optional modules and card readers.

## **Chapter 2: apC/8X Physical Requirements**

Gives an overview of the minimum requirements for the apC/8X, including power supply limitations, apC/8X event storage, and how to connect relay outputs. The chapter also describes how to connect the apC/8X to the host computer.

## **Chapter 3: Identifying Hardware and Mounting the apC/8X**

Lists the hardware supplied with the apC/8X and describes how to mount the unit.

## **Chapter 4: Wiring Card Readers**

Provides information on card reader wiring configurations, wiring equipment to the apC/8X, and installing optional keypads and heaters.

## **Chapter 5: Input and Output Modules**

Describes the optional modules the apC/8X supports and how to install them.

## **Chapter 6: apC/8X Panel Setup**

Gives instructions for setting up the apC/8X panel, including switch and jumper settings.

## **Chapter 7: Testing the apC/8X Installation**

Explains how to test the apC/8X installation, including the readers and the apC/8X main board.

## **Appendix A: Equipment Specifications**

Lists the apC/8X operating specifications, and dimension and weight specifications.

**Appendix B: Calculating Maximum Wire Lengths**

Contains the procedures for calculating maximum wire lengths for the apC/8X installation.

**Appendix C: Packing and Shipping the apC/8X**

Describes what to do if your apC/8X needs to be returned or repaired.

**Appendix D: Modem Settings**

Contains information about configuring apC/8X modem connections.

**Appendix E: Templates and Technical Drawings**

Contains the template for the apC/8X main board and other optional boards. These templates show the locations of jumpers, switches, and major components.

**Appendix F: System Specific Information**

Lists apC/8X switches that are set according to the C•CURE system you are using.

## UL Listing

The apC/8X is UL 294 and UL 1076 listed. This unit is inherently power limited so no additional overcurrent protection is needed. This unit must be installed in a secure location.

## FCC Class A Digital Device Limitations

The apC/8X has been tested and found to comply with the limits for a Class A digital device, pursuant to Part 15 of the FCC Rules. These limits are designed to provide reasonable protection against harmful interference when the device is operated in a commercial environment. This equipment generates, uses, and can radiate radio frequency energy and, if not installed and used in accordance with the instruction manual, may cause harmful interference to radio communications. Operation of this equipment in a residential area is likely to cause harmful interference in which case the user will be required to correct the interference at his own expense.



### CAUTION

Equipment changes or modifications not expressly approved by Sensormatic Electronics Corporation, the party responsible for FCC compliance, could void the user's authority to operate the equipment, and could create a hazardous condition.

## FCC Class B Notes

When using properly grounded and shielded cabling for monitor point and control point wiring, the apC/8X meets the requirements for an FCC Class B device, and the following notice applies:

---

**Note** This equipment has been tested and found to comply with the limits for a Class B digital device, pursuant to Part 15 of the FCC rules. These limits are designed to provide reasonable protection against harmful interference in a residential installation. The equipment generates, uses and can radiate radio frequency energy and, if not installed and used in accordance with the instructions, may cause harmful interference to radio communications. However, there is no guarantee that interference will not occur in a particular installation. If this equipment does cause harmful interference to radio or television reception, which can be determined by turning the equipment off and on, the user is encouraged to try to correct the interference by one of more of the following measures:

---

- Reorient or relocate the receiving antenna.
- Increase the separation between the equipment and receiver.
- Connect the equipment into an outlet on a circuit different from that to which the receiver is connected.
- Consult the dealer or an experienced radio/TV technician for help.

## Canadian Radio Emissions Requirements

This digital apparatus does not exceed the Class A limits for radio noise emissions from digital apparatus set out in the Radio Interference Regulations of the Canadian Department of Communications.



Le present appareil numerique n'emet pas de bruits radioelectriques depassant les limites applicables aux appareils numeriques de la class A prescrites dans le Reglement sur le brouillage radioelectrique edicte par le ministere des Communications du Canada.

## CE Compliance

For CE installations, you must have a readily accessible disconnect device incorporated in the fixed power wiring to the apC/8X.

## Conventions

This manual uses the following text formats, and symbols.

Convention	Meaning
<i>Regular italic font</i>	Indicates a new term.
<b>Note</b>	Indicates a note. Notes call attention to any information that may be of special importance.
	Indicates an important note. Important notes contain information essential to proper operation of the system.
	Indicates a caution. A caution contains information essential to avoid damage to the system. A caution can pertain to hardware or software.

## Important Safety Information

Operating problems are often caused by failure to ground system components properly. Be sure to follow all instructions for grounding described in this manual.

**IMPORTANT**

Changes to the apC/8X not expressly approved by the party responsible for compliance could void your authority to operate the equipment.

The following precautions apply to all procedures described in this manual.

1. To meet life safety requirements, a fail-safe mechanism override must be installed at each card reader exit to allow people to leave the secure area in case of electro-mechanical device failure.
2. The apC/8X device described in this manual could cause electrical shock. Installation and maintenance should be performed only by qualified personnel. Make sure power is removed before the system is installed.
3. The apC/8X and printed circuit boards in the reader devices are susceptible to damage by static electricity. When handling these devices:
  - Make sure your work area is safeguarded
  - Transport all components in static-shielded containers
4. On the apC/8X, star coupler, and Wiegand/proximity star coupler, power wiring to RMs/readers is power limited through PTC protection devices.



## C H A P T E R 1

# 1

## Overview

The Sensormatic *apC/8X advanced processing Controller* is an intelligent access control field panel that serves as the basic building block for Sensormatic C•CURE Systems. Depending on the C•CURE system you are using, the apC/8X can function as the central processor or an access control decision maker for the host computer.

Each apC/8X supports Wiegand, proximity, or magnetic stripe card technologies.

### In This Chapter

---

- apC/8X Basics 1-2
- Card Readers 1-6

## apC/8X Basics

The apC/8X is housed in a 16 AWG metal wall-mounted cabinet which has tamper switches on the front and rear and can be used in a wide variety of configurations. The standard apC/8X has eight inputs, eight outputs, and one RS-485 reader port, capable of handling a maximum of eight readers.

In the basic configuration, the apC/8X's eight card readers are wired in a multi-drop configuration. With the Star Coupler or Mini Star Coupler installed, you can wire the apC/8X's eight card readers to star, multidrop, or a combination of configurations.

---

**Note** As many as 16 apC/8X units can be connected per communications chain. However, for optimum results, the recommended maximum number of apC/8X units per chain is 9, and on a network connection, no more than 6..

---

The panel's static RAM consumes minimal power for storing memory and data. The panel is capable of serial RS232 bus/multidrop RS 485 or dual line communications with an optional board. (Optional boards are described in "Optional Modules for the apC/8X" later in this chapter.)

The apC/8X is also compatible with Sensormatic ACD systems, including the C•CURE 1 Plus, the C•CURE 750, and the C•CURE 800 systems.

### Software-Controlled Options

The apC/8X offers software-controlled features such as timed activation/deactivation commands, 32-bit card numbers, elevator access, dialup mode operation, and anti-passback control. A single apC/8X can use multiple card technologies, site codes, and company codes. The apC/8X's full-year real time calendar/clock allows activation and deactivation of cards on specified days.

### apC/8X Optional Modules

All apC/8X models have supervised inputs. A *supervised* input reports on the status of the wiring between the apC/8X and the alarm device. If that wiring is cut, the system reports an open circuit. If someone tries to jumper across the wiring (prevent the device from reporting), the system

reports a shorted circuit. Supervised inputs can report a total of five conditions to the apC/8X:

- Short
- Open Loop
- Normal
- Alert
- Line Fault (C•CURE 750 and C•CURE 800 systems)

---

**Note** An *unsupervised* input does not monitor the wiring. Unsupervised inputs can report only two conditions to the apC/8X: Normal or Alert. With a star coupler, the apC/8X has eight unsupervised inputs available.

---

The apC/8X also supports the following optional boards:

- apC-I/32 Supervised Input Module
- apC-I/8 Input Bus Module
- apC-R/8 Output Bus Module
- apC-R/48 Relay Expander (1 or 2 modules)
- Standard star coupler
- Mini star coupler
- Wiegand/proximity star coupler

**apC-I/32 Supervised Input Module** The Supervised Input Module (part #132-521) is a separate board, usually mounted directly on the apC/8X motherboard. If one or two apC-R/48 modules are also used, then the apC-I/32 mounts on the outermost apC-R/48.

The apC-I/32 adds 32 supervised Class A two-wire inputs to an apC/8X. A 1 K ohm resistor is factory-installed on all inputs. These resistors must be cut off when you use the associated input. Tolerance on states is  $\pm 5\%$ . The apC-I/32 does not function until the host computer configures the apC/8X.

**apC-I/8 Input Bus Module** The apC-I/8 Input Module (part #AS0073-00) provides eight additional supervised alarm inputs. You can

install up to eight Input Modules on an apC/8X, anywhere along the RM Reader Bus to provide up to 64 additional inputs.

**apC-R/8 Output Bus Module** The R/8 Output Module (part #AS0074-000) connects to the apC/8X reader bus. The Output Module provides eight auxiliary relay outputs. You can connect a total of eight Output Modules to the apC/8X anywhere along the RM reader bus to provide up to 64 auxiliary relay outputs.

**apC-R/48 Relay Module** The R/48 Relay Module (part #132-429) provides 48 additional outputs for elevator, lights, apC/8XTest, HVAC, or control of other security related devices such as closed circuit TV switches and alarm dialers. You can install two R/48 Modules on one apC/8X.

**Standard Star Coupler** The standard star coupler provides another way to connect readers to the apC/8X, since the main apC/8X board has one port for connecting readers. Star couplers let you wire readers in a star (each reader is individually wired to the apC/8X) or daisy-chain configuration. The apC/8X still controls a maximum of only eight readers. You can configure one star coupler per apC/8X, with inputs and outputs numbered from 9 through 16.

**Mini Star Coupler** The mini star coupler gives you an economical way to wire readers. However, the module contains no additional inputs or outputs.

**Wiegand/Proximity Star Coupler** The Wiegand/Proximity star coupler (WSPC) is a two board set that lets you connect Wiegand, Wiegand-compatible, and proximity readers with Wiegand output directly to the apC/8X without using RMs. Both boards in the set provide four reader connections and four inputs for a total of eight reader connections and eight inputs.

---

**Note** If you are using a WSPC, you can only use seven readers, disabling the eighth reader when using R/8 Input or R/8 Output boards.

---

## Battery Backup

The apC/8X has two types of battery backup: onboard memory and operational power. The operational power battery backup, known as the Advanced Power System (apS), gives the apC/8X internal powerfail capability. Some versions of the apS also have a powerfail input available. Contact Sensormatic for further information about these versions.

## Card Readers

A card reader is made up of a read head or reader electronics and a small circuit board, called a *personality board* or *module*. These boards fit into the reader housing and contain the electronics for accepting magnetic stripe and Wiegand card technologies. By setting a switch or jumper on the board, you can determine the type of cards a reader will accept.

The apC/8X uses the following personality module:

- RM Series, including the RM-4.

The RM module is approximately 4.5" by 3.5" (11.8 by 9 cm) and can be installed in the polycarbonate reader housing or in a 6" x 4" (minimum) junction box. Each reader that contains an RM module is easily configured with a six position DIP switch. A 0-F rotary switch defines the address and an onboard tamper switch protects the electronics.

Each RM reader provides two class A supervised inputs on the module and two outputs for an ARM module (Part #131-912). See "Setting Up a Reader" on page 4-15 for further information on card readers.

### Magnetic Stripe Readers

The magnetic stripe reader is enclosed in an all weather housing with a slot through which a magnetically coded card is passed, or "swiped." The RM-4 personality module decodes the data on the card and transmits it to the apC/8X for processing.

### Wiegand Readers

There are three types of Wiegand card readers:

- Swipe reader, through which a card is passed
- Insertion reader, into which a card is inserted and removed
- Key reader, into which a key shaped card is inserted and removed

A sensing coil inside a Wiegand reader creates a magnetic field. When the wires inside the card interact with the magnetic field, they create low voltage impulses in the coil. Depending on the arrangement of the wires in the card, the voltage is either positive or negative. The module translates the impulses and transmits the information to the apC/8X for processing.

Most swipe, insertion, and key Wiegand Readers have a single red LED which indicates the status of the door. Some models are available with a bi-color LED to allow greater flexibility in reporting the door status. Sensormatic RM Wiegand readers have a three-LED display.

Appendix A contains a table listing the different types of Wiegand readers and their part numbers.

**Proximity Readers** The proximity reader transmits a radio frequency signal. A proximity card is a radio frequency transponder, or tag, which consists of an antenna coil, and an integrated circuit chip encoded with a unique identification number. When a card is passed near the reader, it energizes the card's antenna, causing it to send its identification number to the reader. The card and reader do not make physical contact. LED indicators for proximity readers vary according to manufacturer.

See Appendix A for a listing of the proximity reader options.

## The Auxiliary Relay Module

The Auxiliary Relay Module, or ARM-1 (part # 131-912), is an optional relay board that takes a logic-driven signal from the reader and drives or switches a 12/24V relay for the door strike or for other use. The ARM-1 is 1.7" by 0.75" (4.3 by 1.91 cm) in size. It is mounted inside the protected area no more than 25 feet (7.6 m) from the RM reader. The ARM-1 contains 1 Form C relay capable of driving a 30V, 2A non-inductive or 1A inductive load.

---

**Note** You can connect two ARM-1 modules to each RM-4 module.

---

## Paired Readers

You can pair any two readers if they are configured with the same door contact at the host computer. Paired readers coordinate door strike control and door contact shunting between themselves. Note that request-to-exit does not function if a door is configured with two readers.





## CHAPTER 2

# 2

## apC/8X Physical Requirements

This chapter describes physical requirements for the apC/8X, and describes how to replace EPROMs.

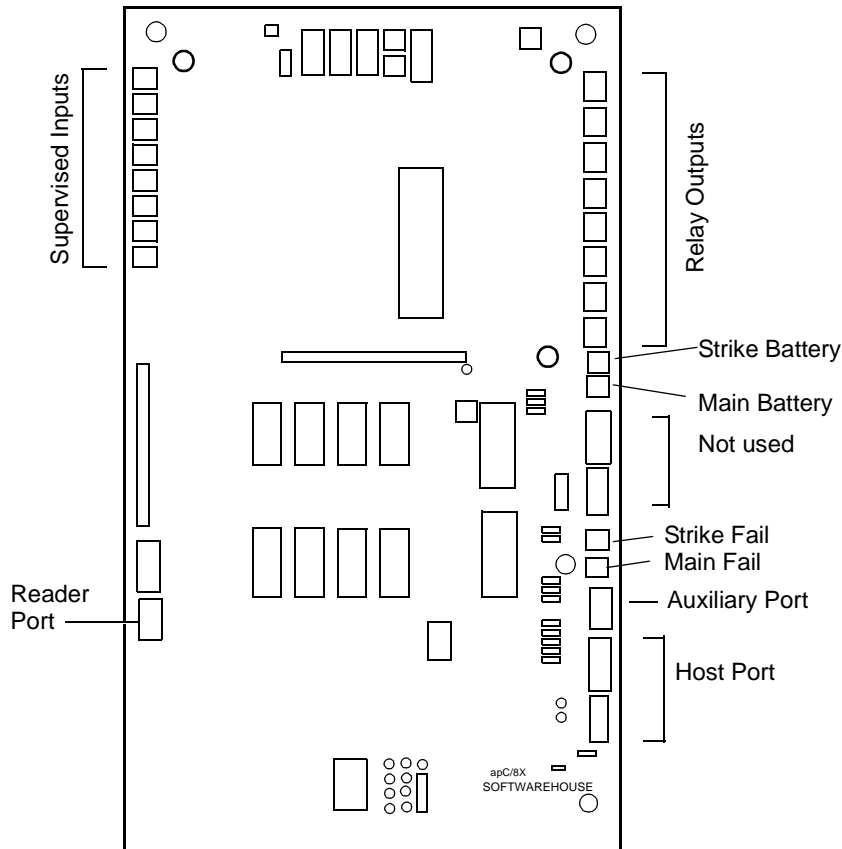
### In This Chapter

---

- External Devices and the apC/8X 2-2
- Equipment Wiring Requirements 2-4
- apC/8X Event and Card Storage 2-8
- apC/8X Power Supply Limitations 2-11
- Connecting the apC/8X to a Host 2-14
- Replacing the apC/8X EPROMs 2-19

## External Devices and the apC/8X

External devices connect to the apC/8X via numbered ports located on the left and right sides of the board. Groups of ports are reserved for connecting specified types of devices. See Figure 2.1. Connectors and device types are listed in Table 2.1.



**Figure 2.1 External Device Connections to apC/8X Ports**

**Table 2.1 External Device Connectors**

<b>Device(s)</b>	<b>Connector</b>
Inputs (2 pins per input)	P9-P16
Card readers (four pins per reader)	P43
Relay outputs (3 pins per output)	P1-P8
Power failure input (2 pins per input)	P21
Aux port (5 pins)	P36
Host computer (5 pins)	P30 or P32
Not used	P26 or P31
Strike Power Fail (2) *	P23
Main Battery Low (2 pins) *	P27
Strike Battery Low (2 pins) *	P28
*Contact factory for support information	

## Equipment Wiring Requirements

Table 2.2 lists the wiring requirements for the apC/8X and its components. Consult the Belden specifications for information on capacitance and resistance.

**Table 2.2 Equipment Wiring Specifications**

Signal	From	To	Belden #	Gauge	# Prs.	Shielded?	Max Length
RS-232 Comm	Host	apC	9855	22	2	Yes	50 ft.
RS-232 Comm, 5-wire	Host	apC	8303	22	3	Yes	50 ft
RS-485 Comm	Host	apC	9842*	24	2	Yes	4000 ft.
Comm	apC	RM/MRM Input/Output Modules	9841*	24	1	Yes	4000 ft.
Power	apC	RM/MRM Input/Output Modules	8442/8461	22/18	1	No	Appendix B
Control	apC/ ARM	Strike	8461	18	1	No	Appendix B
Supervised Unsupervised Input	apC/I/32	Input	8442/8461	22/18	1	No	2000 ft.
Request-to-exit	RM-4 MRM	Switch	8442/8461	22/18	1	No	2000 ft.

\* For plenum or underground applications, use Manhattan M63995 for 2 pair only, 150 ohm, 8.8 pf/ft or Belden 89182 for 1 pair 22 AWG, 100 ohm 12.95 pf/ft. Control, Supervised and Unsupervised Input cables must be shielded for FCC Class B operation.

**Table 2.2 Equipment Wiring Specifications (continued)**

<b>Signal</b>	<b>From</b>	<b>To</b>	<b>Belden #</b>	<b>Gauge</b>	<b># Prs.</b>	<b>Shielded?</b>
Door contact	RM-4/ MRM	Contact	8442/8461	22/18	1	No
Relay	RM-4/ MRM	ARM-1	9462	22	1	Yes
Reader	RM-4/ MRM	Wiegand/ Prox. Read Head	9536	22	3	Yes
Reader	Wiegand Prox Star Coupler	Wiegand/Prox reader				
		Indala	9536/9537	24	3	Yes
		Sensor	9941	22	5-wire	Yes
		Hughes/ IDI	8723	22	2	Yes

## Cabling

You can substitute the following plenum-rated cables for the cables referenced in this manual for host-to-apC/8X or apC/8X to RM:

- Use Manhattan (PN#M63995) for 2-pair only, 24 AWG, 120 ohm, 12.5 pf/ft, with foil shield. For the apC/8X-to-RM connection, use only one of the pairs.
- Use Belden 89729 for 2-pair, 24 AWG, 150 ohm, 8.8 pf/ft. Use Belden 89182 for 1-pair 22 AWG, 100 ohm, 12.95 pf/ft., with foil shield. These two cables are also rated for underground burial.

## apC/8X Event and Card Storage

Event storage space in the apC/8X's memory is automatically adjusted according to the space required for storing cardholder information. Increasing the number of records stored decreases the number of events (transactions) that the memory can hold. Adding optional software features, such as elevator control (10 bytes), anti-passback (4 bytes) activation and expiration dates (4 bytes each), and 32-bit card records reduces cardholder counts and event storage space. Use the following formula to estimate the number of cards that can be supported for a given memory size.

$$\text{number of cards} = \frac{(\text{memory\_size} - 64) \times 1024 - (\text{events} \times 10)}{\text{card\_record\_size}}$$

where:

Memory\_size is the total APC RAM in kbytes.

Card\_record\_size is the number of bytes comprising a record. A typical card\_record\_size for an 800 system can be estimated as follows:

Item	Bytes
Card number	4
Issue + PIN	4
Activation date	4
Expiration date	4
Clearances	10
<b>TOTAL</b>	<b>26</b>

Events are the average number of events that an apC must store between uploads to the host. A typical value is 1000.



Table 2.3 lists the apC/8X memory requirements according to the number of cardholder records supported.

**Note** The values in this table are approximate. Your exact memory requirements depend on the number of cards and optional features in your system. The calculations assume an event record memory of 10k bytes, or 1000 events. The more options you add, the fewer the number of cards the apC/8X can support.

**Table 2.3 apC/8X Memory Requirements**

If SRAM Is	Number of Cardholder Records with No Elevator	Number of Cardholder Records with One Elevator
256K	7,177	5,184
512K	17,260	12,465
1M	37,425	27,029
2M	77,754	56,156
4M	158,414	114,410

## Calculating apC/8X Memory Requirements

Use the following formula to determine the exact memory requirements in kilobytes for a given number of cardholder records and events if the data from the above table is not sufficient

$$\text{memory\_size} = 64 + \frac{\text{card\_record\_size} \times \text{num\_cards} + (\text{events} \times 10)}{1024}$$

**Sample Calculation**

Suppose your site had the following requirements:

- 5,000 26-byte cardholder records must be maintained in memory
- The apC/8X must buffer 1,000 offline events
- The apC/8X is configured for local anti-passback and elevator control

Substituting these values in the formula :

$$\text{memory\_size} = 64 + \frac{26 \times 5000 + (1000 \times 10)}{1024}$$

The result from the above calculation is 200.718, so you would need to purchase an apC/8X with 256K of memory.

## apC/8X Power Supply Limitations

The apC/8X is rated for a maximum continuous load at 12 VDC of 3.3 A. However, Sensormatic recommends that you do not exceed a total current load of 2.8. The apC/8X voltage tolerance is +5V +/-5%, - +12V +/-15%.

Table 2.4 lists typical currents for the apC/8X and its components.

**Table 2.4 Current Drawn By apC/8X and Components**

Component	Current in Milliamperes
apC/8X main board	175mA
RM-4 personality board	75mA
Star coupler	60mA (+ relay)
Mini star coupler	40mA
apC R/48 option board	60mA (+ relays)
apC I/32 option board	310mA
apC/I32 LED	140mA
Active relay (any board)	20mA
Wiegand/proximity star coupler (lower board)	60mA
Wiegand/proximity star coupler (upper board)	70mA
R/8 option board	100mA (+ relays)
I/8 option board	120mA
Active Relay	25mA

## Power Supply Limits

### Sample Calculation

Suppose you are powering eight readers on an apC/8X using a star coupler. The reader you are using requires 180mA of current. Use the following formula to calculate the maximum current draw.

$$(8 \times 180) + 175 + 60 = 1.7A$$

↑     ↑     ↑  
RM   apC/8X   Star Coupler

If your combination of apC/8X accessories requires more current than the recommended maximum, you must power some of your readers locally. Software House recommends that you use linear supplies for this auxiliary reader power.

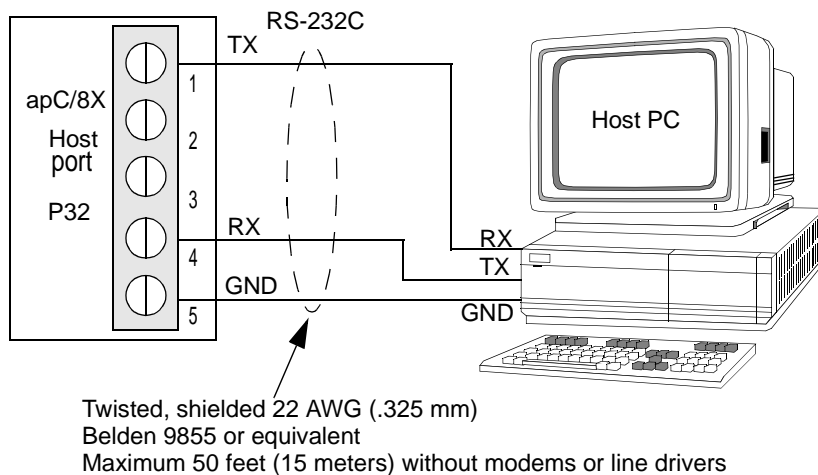
When you use the apC/8X internal power supply to power readers, observe the limitations listed in Table 2.5.

**Table 2.5 Power Supply Limitations**

<b>Reader Type</b>	<b>Part Number</b>	<b>Current Required</b>
Indala	ASR-110, ASR-112	150 mA
	ASR-103, ASR-105	150 mA
	ASR-101	150 mA
	PR-10, PR-12, PR-5	130 mA
	ASR-120, ASR-122	350 mA
	PR-20, PR-22	350 mA
Sensor Eng.	WR1 or WR2	30 mA
Hughes	MiniProx	60 mA
	ProxPro	100 mA
	MaxiProx	200 mA

## Connecting the apC/8X to a Host

The host port **P32** connects the apC/8X to a host computer (see Figure 2.2). A single apC/8X can connect to the host via RS-232C format. Multiple apC/8Xs communicate via an RS-485 chain, but the apC/8X chain must communicate with the host through an RS-232 to RS-485 converter.



**Figure 2.2 RS-232C Three-wire Connection between apC/8X and Host**

You can use modems, line drivers, or other communications devices to increase the distance between the host and the apC/8X. The next four sections describe these connections:

- RS-232C
- RS-485
- Modems for directly connected apC/8Xs
- Modems for dialup apC/8Xs

## Configuring apC/8X Jumpers

Configure apC/8X jumpers W8 and W11 through W15 for the host communications format you are using. For host communication using the RS-232C communication protocol, set the jumpers to the **B** position. For host communication using the RS-485 communication protocol, set the jumpers to the **A** position.

See Chapter 6 for additional jumper definitions and settings.

## RS-232C Connection

1. Use twisted, shielded 22 AWG (0.325 mm) cable, Belden type 9855 or equivalent.
2. Connect the cable shield to the apC/8X chassis ground.

The apC/8X can be no further than 50 ft. (15 m) from the host, unless you extend this distance with a modem, line driver, or other communications device. Table 2.6 shows how to connect the apC/8X directly to the host.

**Table 2.6 apC/8X Connection to Host PC**

apC/8X		Host		
Pin	Signal	DB-25 Pin	DB-9 Pin	Signal
P32-1	Data transmit (TX)	3	2	Data receive (RX)
P32-4	Data receive (RX)	2	3	Data transmit (TX)
P32-5	Ground	7	5	Ground (GND)

## RS-485 Connection

Use RS-485 transmission to connect apC/8Xs in a chain.



### In a multidrop configuration:

1. Open W9 and W10 on all apC/8X panels except the last one in the chain.
2. Use twisted, shielded 24 AWG (0.288 mm) cable, Belden type 9842 or equivalent between the apC/8Xs.
3. Tie the shield wires together where the two cables meet, but do not connect the shield at the apC/8X.
4. Ground the shield wires at the converter board. A converter board is a small circuit board with attached connectors into which you plug the connectors from the host and the apC/8X chain.

If your converter does not have an available point to connect the shield to chassis ground, connect the shield at the chassis ground connection on **one** apC/8X only. A multidrop line can have a total length of 4,000 ft. (1,219 m).

## RS-232C to RS-485 Converter

You must use an RS-232C to RS-485 converter to convert the chain to RS-232C at the host. Sensormatic recommends a Black Box model IC108A or equivalent. More information on the converter can be found on the manufacturer's web site, <http://www.blackbox.com/>

Plug connectors from the apC/8X and the host into the converter. The pin connections for the apC/8X, converter, and host are listed in Table 2.7 and Table 2.8.

**Table 2.7 apC/8X Pin to Converter Pin Connections**

apC/8X P32		RS-485 Converter	
Signal	Pin #	Signal	Pin#
TX-	1	RX-	6
TX+	2	RX+	24



**Table 2.7 apC/8X Pin to Converter Pin Connections**

apC/8X P32		RS-485 Converter	
Signal	Pin #	Signal	Pin#
RX+	3	TX+	22
RX-	4	TX-	4
GND	5		

**Table 2.8 Converter to Host Connections**

Converter	RS-232	Host	RS-232	
Signal	Pin #	Signal	Pin#	
Connector Type	DB-25		DB-25	DB-9
RX	2	TX	2	3
TX	3	RX	3	2
GND	7	GND	7	5

### Line Drivers for directly connected apC/8Xs

You can use a short haul modem or line driver to extend the distance the apC/8X can be located from the host. Communication between the modem and the apC/8X adds two additional signals to the three required for communication between the apC/8X and the host. For information about connecting a modem to the host, see the appropriate documentation for your host.

## Modems for dialup mode apC/8Xs

Use dialup mode to connect an host to apC/8Xs at a remote location using standard, voice-grade telephone lines instead of hardwired or leased telephone lines. For many of your applications, dialup mode can be more convenient and cheaper than other communications modes.

In dialup mode, the apC/8X modem must use DTR. Connect modems using standard straight through cables with DB-25 connectors.



### CAUTION

Connect DTR to the apC only if you are connecting the apC/8X to a modem. Using DTR with an apC/8X connected directly to the host can result in hardware damage.

The pins used for dialup are listed in Table 2-10. See “Dialup Modem Setting D-1” for information about DIP switch settings.

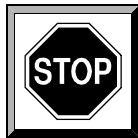
**Table 2.9 apC/8X to Dialup Modem Connections**

apC/8X		Modem
P10 Pin #	DB-25 Pin #	Signal
1	2	Data transmit (TX)
2	20	DTR (connected for dialup only)
(3)	(5)	Required for some modems, close SW1:3 for 5-wire connection.
4	3	Data receive (RX)
5	7	Ground (GND)

## Replacing the apC/8X EPROMs

When Sensormatic updates an apC/8X EPROM, you may need to replace the EPROM at your site. If your panel is equipped with flash EPROMs and the host supports flash downloading, firmware updates and enhancements are made through the host. You do not need to replace flash EPROMs.

For Flash EPROMs, follow the instructions provided with the software. For non-flash EPROMs, proceed as follows



### CAUTION

EPROMs are sensitive to electrostatic discharge. Change the EPROMs only when wearing a grounding wrist strap.



#### To replace the apC/8X EPROMs:

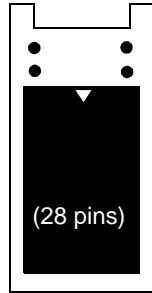
1. Remove power from the apC/8X.
2. Using a removal tool, carefully remove the EPROMs from sockets U42 and U43.
3. Place the new EPROMs in the appropriate sockets.
4. Carefully check the orientation of the EPROMs. The notch on the EPROM should be placed toward the top of the apC/8X module. Ensure that all legs fit into the socket correctly.

---

**Note** EPROMs fit into the socket differently, depending on the size of the EPROM. The legs of EPROM 27C512 do not fill every hole in the socket. Leave the top two rows of holes open. The legs of EPROM 27C1024 fill the entire socket. Figure 2.3 shows this difference.

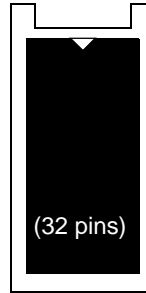
---

Leave top 2 rows  
of holes open



EPROM 27C512

EPROM legs  
fill all holes



EPROM 27C1024

**Figure 2.3 Replacing EPROMs on the apC/8X**

A large, white, stylized number '3' is centered within a dark gray square. The square is set against a lighter gray background. The number '3' has a thick, bold appearance with a slight shadow effect.

# Identifying Hardware and Mounting the apC/8X

This chapter describes the apC/8X hardware components checklist, how to mount the apC/8X cabinet, how to connect a relay output for monitoring the primary AC line and how to connect the Advanced Power System.

## In This Chapter

---

- apC/8X Hardware Components 3-2
- Mounting the apC/8X Cabinet 3-3
- Connecting the apC/8X Input Voltage 3-5
- Connecting a Power Failure Input 3-5
- Connecting the Advanced Power System (apS) 3-5

## apC/8X Hardware Components

The apC/8X is shipped with the following components.

Qty	Description
1	PCB, door illuminator (pre-installed)
7	cable tie mounts (pre-installed)
7	cable ties (pre-installed)
1	6-32 X 1/4 nut (pre-installed)
8	starwashers, #6 external (pre-installed)
2	pushbutton switches (pre-installed)
4	4-40 x 1/4 screws (pre-installed)
4	4-40 x 1/4 nuts (pre-installed)
1	power supply assembly (optional)
1	chassis ground cable assembly (pre-installed)
1	door illuminator cable assembly (pre-installed)
1	apC/8X cabinet enclosure
6	6-32 x 3/8 screws (pre-installed)
1	PCB (pre-installed)
1	18 gauge solid 1" long wire (pre-installed)
1	installation map label (pre installed on apC/8X cabinet door)
1	apC/8X label (pre-installed)
1	Sensormatic label (pre-installed)
1	power limit label (pre-installed)
2	foam end caps (pre-installed)

Qty	Description
1	FCC/UL/CE label (pre-installed)



### IMPORTANT

Before handling and installing any component, follow these precautions:

- Discharge your body's static electricity charge by touching a grounded surface
- Wear a grounding strap and work on a grounded static protection mat.
- Do not slide a component over any surface.
- Limit your movements during the installing process to reduce static electricity.

## Mounting the apC/8X Cabinet

Before you begin any installation, make sure the installation locations provide enough space for the apC/8X, the card readers, and the necessary electrical conduit. Appendix A lists the hardware dimensions for the apC/8X, boards, and readers.

Figure 3.1 gives the dimensions for mounting the apC/8X cabinet with board.

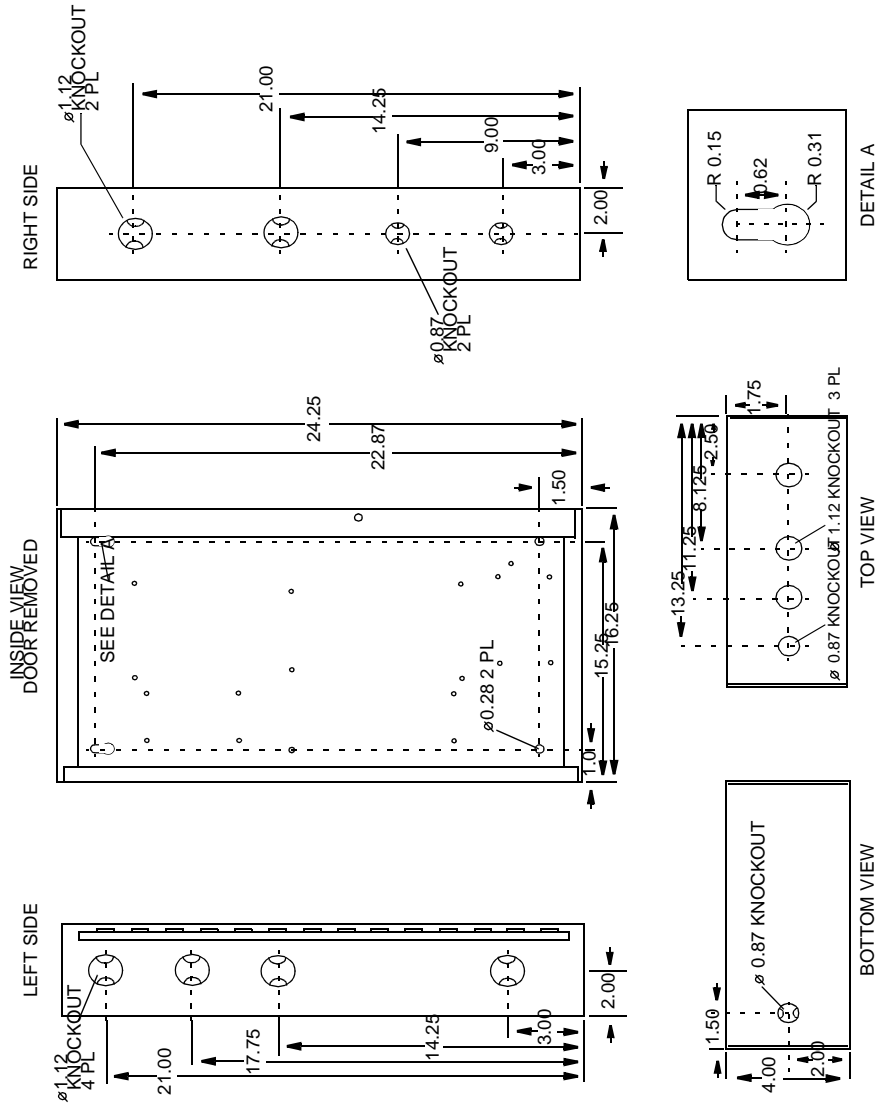


Figure 3.1 apC/8X Mounting Specifications



## Connecting the apC/8X Input Voltage

The power supply for the apC/8X is already installed in the cabinet when shipped. It automatically accepts input voltage range from 90 to 260 VAC, 47 to 440 Hz. If you need to replace the apC/8X power supply fuse, use a 2A, 5TT fuse (Bus 6MA 2A/250V).



### Connecting the apC/8X:

1. Connect the apC/8X panel to a fused or similarly protected AC main.
2. Connect the earth ground from the AC main to the ground stud at the right of the power supply. The earth ground should be the first wire attached to the stud.
3. Secure the earth ground with the supplied lock washer and nut.

You can place other existing connections on top of this nut.

## Connecting a Power Failure Input

Many uninterruptible and battery backup power supplies provide a relay output for monitoring the primary AC line. The UPS connector P21 provides a normally-closed power failure input.

If you use a UPS or battery backup power supply with the apC/8X, connect the relay common and normally closed outputs to P21. This input reports all AC faults to the host computer; you do not have to configure it to do so. To bypass the UPS input, place a piece of hookup wire or a wire jumper across its terminals.

---

**Note** On new modules, the hookup wire may already be in place.

---

## Connecting the Advanced Power System (apS)

The apS is an optional power supply unit, providing uninterrupted power backup for the apC/8X. It has knockouts that line up directly to those on

the apC/8X, and compatible terminal blocks and cable harnesses that keep wiring to a minimum. (See Figure 3.2).

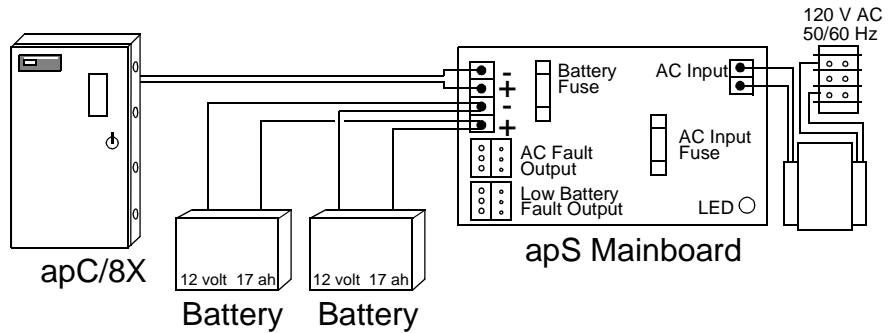


Figure 3.2 apS Connection to apC/8X

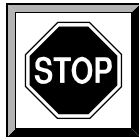
The apS provides two relay outputs for connecting inputs to the apC/8X. One relay is connected to the powerfail input on the apC/8X and indicates when AC power is lost. The second output is connected to a general purpose apC/8X input. It indicates low battery voltage or impending loss of backup power. LEDs on the cabinet door of the apS indicate AC power loss and the state of the battery charge as relative battery voltage level.

The apS low battery fault and power fault outputs can be looped together and attached to the apS fail on the apC/8X or tied to separate monitor points on the apC/8X.

The apS comes with 17 Amp hours of backup capacity; you can order an additional battery to increase this capacity to 34 Amp hours. The length of time that the apS can power an apC/8X and readers depends on several factors:

- the configuration you are using
- the number of card readers connected to the apC/8X panels
- the number of batteries in the apS

See Appendix E for further information about the apS.



## **CAUTION**

You must remove the power supply from within the apC/8X before attaching the apS.



## CHAPTER 4

# 4

# Wiring Card Readers

This chapter gives detailed information for mounting, wiring and installing a card reader with an RM personality board. The chapter also describes how to install the Auxiliary Relay Module (ARM-1).

### In This Chapter

---

- Card Reader Configurations 4-2
- Reader Wiring Configurations 4-9
- Setting Up a Reader 4-15
- Installing the Auxiliary Relay Module (ARM-1) 4-18
- Wiring for Relay Outputs 4-22
- Wiring Inputs to the RM 4-25
- RM-4 Personality Module with Third Party Reader 4-30
- Optional Heater Kit 4-36

The only special tool required for wiring is a security screwdriver (part #132-183), used to install the security screws in the RM series reader.

---

**Note** An RM reader must be wall mounted. The mounting plate for RM readers is designed to mount on a standard doublegang switch box.

---



### **IMPORTANT**

Before you begin installation, read all the instructions in this chapter. Be sure to follow these precautions when handling any equipment:

Discharge your body's static electricity charge by touching a grounded surface.

Wear a grounding wrist strap and work on a grounded static protection mat.

Do not slide a component over any surface.

Limit your movements during the installation process to reduce static electricity.

## **Card Reader Configurations**

The apC/8X supports several types of card readers. The following readers connect to the apC/8X reader ports via the RM personality board.

- Devices that produce Wiegand output, including:
  - Wiegand card readers
  - Biometric devices
  - Bar code readers
- Proximity readers that produce Wiegand output, including:
  - Indala one and two-stage
  - HID
  - Newmark Cryptag

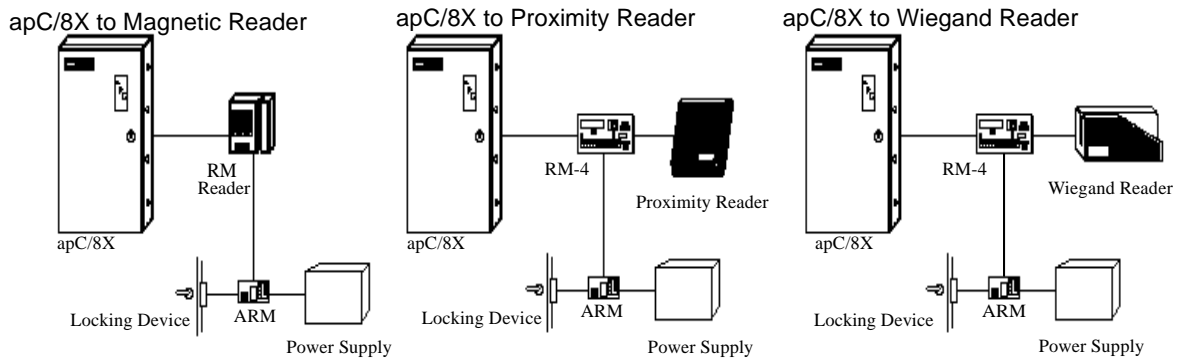
- Standard magnetic stripe readers
- Magnetic stripe Mullion readers

For a standard apC/8X, readers are connected in multidrop configuration only. For an apC/8X with a star or mini star coupler, readers can be connected in three configurations:

- Multidrop
- Star
- Multidrop Star Combination

Before you install your readers, be sure to plan their configuration exactly.

Figure 4.1 shows sample wiring configurations for magnetic, proximity, and Wiegand card readers.



**Figure 4.1 Wiring Configurations with Personality Modules for Some Reader Types**

## Wiring Configurations

You can wire RM readers in a multidrop or star configuration. A multidrop line uses an RS-485 bus to connect up to two readers and up to four I8 Input Modules and up to four R8 Output Modules to the apC/8X reader port. See Figure 4.2 for an illustration.

The star configuration is the simplest way to connect readers to an apC/8X. A two-wire, RS-485 communications line connects each single reader to its own port on the apC/L.

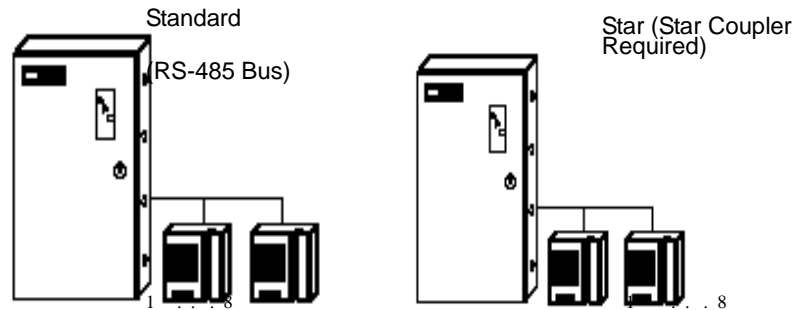
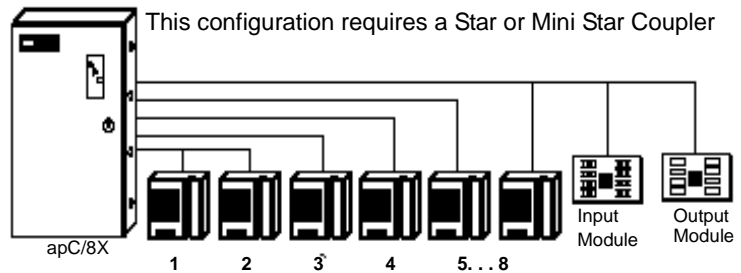


Figure 4.2 Multidrop and Star Configurations



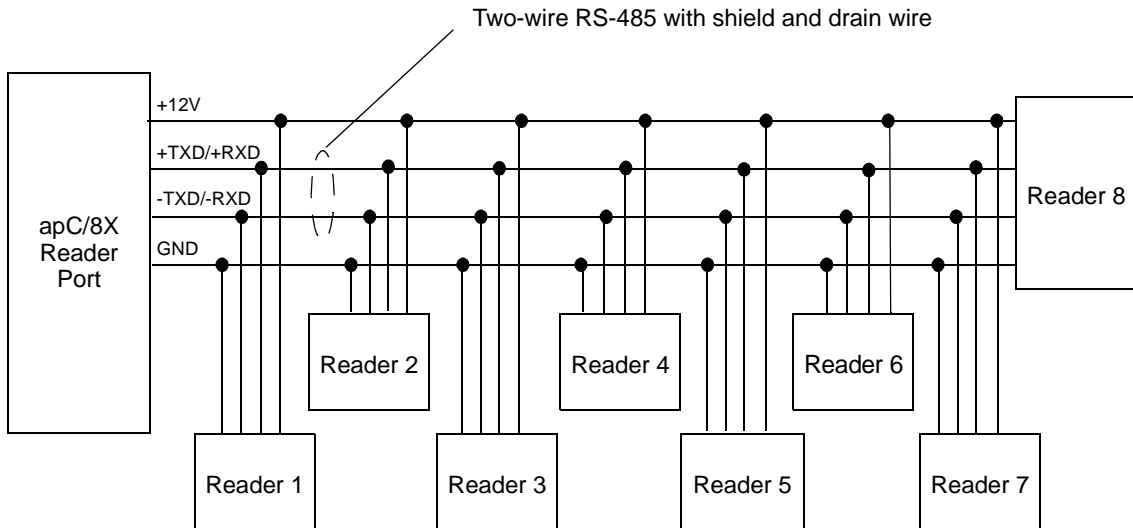
The multidrop/star combination is useful in a system that spans several buildings hundreds of feet apart. Figure 4.3 illustrates the multidrop/star combination.



**Figure 4.3 Multidrop/Star Combination Configuration**

**Connecting Multidrop Line** When setting up a multidrop configuration, locate readers no more than 3 ft. (0.91 m) from the multidrop line. See Appendix B for information about calculating the maximum distance a reader can be from an apC/8X.

See Figure 4.4 for information on connecting the readers and apC/8X in a multidrop configuration.



**Figure 4.4 Connecting the apC/8X and Readers in a Multidrop Configuration**

---

**Note** The last reader in the chain is the one located electrically farthest from the apC/8X. In Figure 4.4, the last reader in the chain is Reader 7.

---

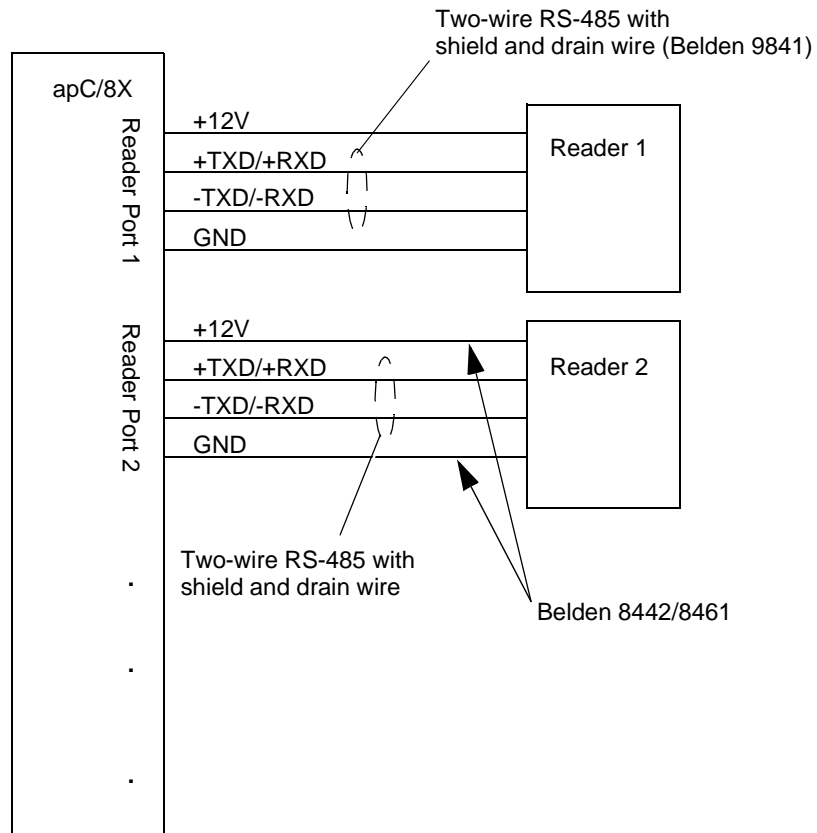
*For each RM:* Make sure switch SW3-5 is Open.

Ground each RM separately. Connect drain wires together at each reader and ground the wires to the apC/8X cabinet. Do not connect the + drain wire to an RM.

See "Templates and Technical Drawings" in Appendix E for detailed wiring diagrams.

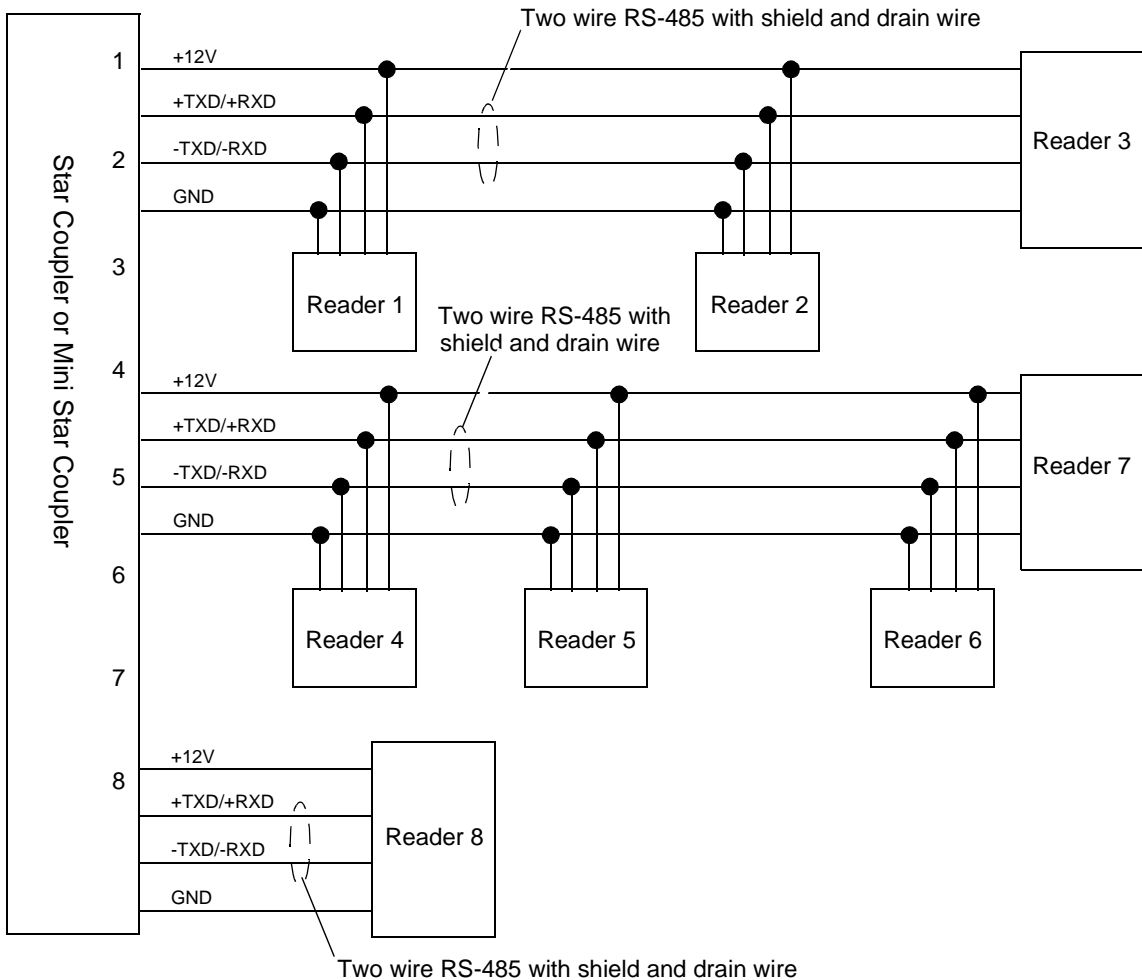
**Star Configuration** Figure 4.5 illustrates an apC/8X with two readers connected in a star configuration. This configuration is only for apC/8Xs using a star or mini star coupler. Connect the drain wire to the apC/8X cabinet, leaving it floating at the reader.

*For an RM:* Terminate with SW3-5 Closed.



**Figure 4.5 Connecting the apC/8X and Readers in a Star Configuration**

**Multidrop Star Configuration** When connecting readers in a multidrop configuration, locate them no more than 3 ft. (0.91 m) from the multidrop line. Figure 4.6 illustrates how to connect the apC/8X in a multidrop star configuration.



**Figure 4.6** Connecting the apC/8X and Readers in a Multidrop/Star Configuration

# Reader Wiring Configurations

This section describes how to connect readers to the apC/8X reader ports in one of three ways:

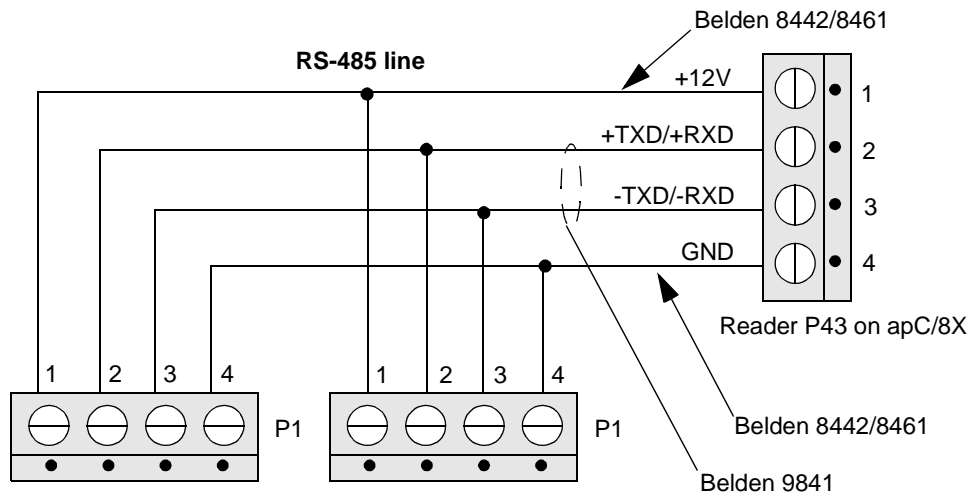
- To the apC/8X in a multidrop configuration
- To the standard star coupler
- To the Wiegand/proximity star coupler

**Multidrop Configuration** You can connect readers to the apC/8X in a multidrop configuration.



### Connecting a multidrop:

1. Use an RS-485 line to connect the P1:1 connector of each reader in the line to Pin 1 of the apC/8X's P43.
2. Connect the remaining pins in sequence. Figure 4.7 shows the connections for a multidrop line configuration.

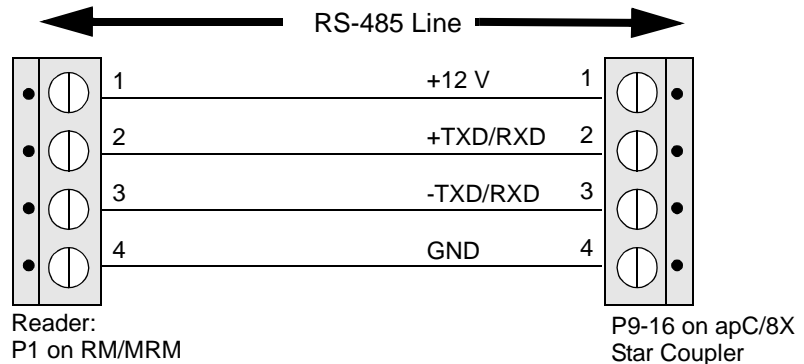


**Figure 4.7** Connecting Devices to the apC/8X in a Multidrop Configuration

3. Ground data wire shields at the host (not at the reader).

**Standard Star Coupler** Each reader port on the star coupler is a group of four pins labelled P16 through P9. The four wires from each reader connect to an apC/8X star coupler via the supplied connector.

Figure 4.8 indicates the pin and contact numbers for connecting readers in a star configuration.



**Figure 4.8 Connecting Devices to apC/8X Star Coupler in a Star Configuration**

---

**Note** Ground data wire shields at the host, not at the reader.

---

For star configurations, the apC/8X reader port number does not have to match the reader address. For multidrop configurations, you can use any star coupler reader port.

**Wiegand/Proximity Star Coupler (WPSC)** An eight-position DIP switch located on the lower Wiegand/proximity star coupler board lets you enable or disable individual readers on both boards. You should enable only those readers connected to the WPSC and disable any reader ports not physically wired to readers. This speeds operation, since the system polls all reader chips that are switched ON.

When you test your configurations, you can take any reader off-line by moving the appropriate switch to the OFF position and leaving the power on. To ensure that the reader is reported on-line when you return the switch to ON, do one of the following.

- Reset the WPSC using the reset switch (SW2) on the lower board  
or
- Reset the apC/8X using the reset switch (SW7) on the apC

**Reader Power Selection** The WPSC can provide 12 VDC or 5 V DC to readers. Set the W3 jumper to indicate the power requirements for the readers (see Table 4.1). All three power sources are protected from externally caused shorts to GND by a varistor.

Jumper W3 sets a single voltage, available for readers powered from the apC. If you must use readers with different voltage requirements, use local power for those readers. All readers that use separate power supplies must have a common ground to the WPSC ground (P9-1 or any reader port pin #6).

**Table 4.1 Power Settings for Readers**

Required Power	Reader Type	W3 Setting
+5V	Sensor	C position
+12V	Indala	A position
External power supply connected to P9: P9-1 is GND, P9-2 is positive power.	Any	B position

**Note** To supply external power or for additional power, use the P9 connector. P9 supplies power to all readers connected to the WPSC. Use P9 only when reader power requirements exceed or differ from the apC/8X power supply and use the W3 jumper in position B only.

**IMPORTANT**

To avoid damage to connected readers, make sure that the P3 power jumper is set correctly for your reader voltage before you apply power to the apC/8X.

**Using Readers with a Wiegand/Proximity Star Coupler** You can use RM readers with Wiegand/Proximity Star Coupler (WPSC) readers by connecting the reader to the apC/8X reader port P43. You must disable the corresponding reader address on the WPSC.

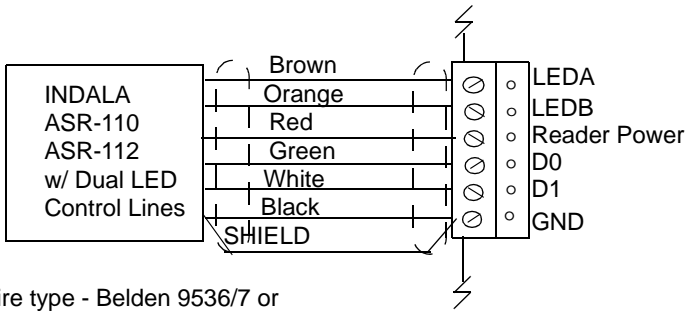
---

**Note** You cannot use a star configuration of RMs on an apC/8X that also uses a WPSC. You must connect the RMs to the apC/8X in a multidrop configuration on the main apC/8X board.

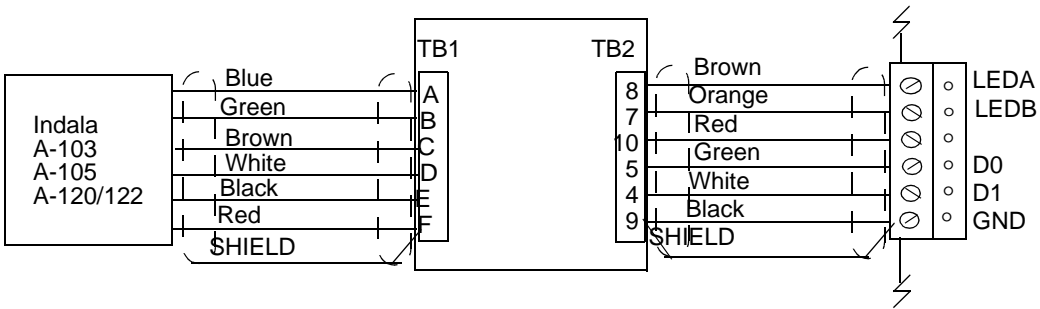
---

Figure 4.9 shows the reader port connections and wiring for the Wiegand/proximity Star Coupler.





Wire type - Belden 9536/7 or equivalent, 24 AWG  
6/7 Conductor 500' Max



Wire type - Belden 9536/7 or equiv. 75' max.

Wiegand/Prox Star Setup  
W2 - Out  
W2 - A

Figure 4.9 Wiegand/Proximity Star Coupler Reader Port Connections

**LED Control** The WPSC supports bicolor LED control, using either dual or single wire. To use two wire control for all readers, remove the jumper from W2. See "Templates and Technical Drawings" in Appendix E for a schematic drawing.

For single wire control for all readers, place a jumper on W2. See "Templates and Technical Drawings" in Appendix E for a schematic drawing.

## Setting Up a Reader

### Setting Reader Type for an RM-4 Personality Module

Set the reader type using DIP switch SW3-1 on the RM-4. If you are setting up a magstripe reader, set SW3-1 to the Open (Off) position. If you are connecting a Wiegand or proximity reader, set SW3-1 to Closed (On). If you are setting up the last reader on a multidrop line, set SW3-5 to On.

Use the information in the following table to set the reader type.

Reader Description	Switch Number	Switch Setting
Magnetic Stripe	SW3-1	Open (OFF)
Wiegand/Proximity	SW3-1	Closed (ON)

There are five other reader configuration switches. Table 4.2 indicates what each switch controls and how to set them for your site.

---

**Note** The RM must be powered off then back on for changes to take effect.

---

Table 4.2 Reader Configuration Switch Settings

This Switch..	Controls...	When Open... (Switch OFF)	When Closed... (Switch ON)
SW3-1	Reader type	Magnetic stripe	Wiegand/proximity
SW3-2*	LCD	Present (RM2L only)	You do not have an LCD display
SW3-3: Set this switch ON when using external reader heads which have bi-colored LED's. Wire the green control wire to the green LED (J4-4) and the red control to the red LED (J4-2).	LED option	Normal	External bi-color
SW3-4	Tamper Switch	Enabled	Disabled
SW3-5	End of line terminator	Not last	Last unit in line
SW3-6: Set this switch ON when mixing RM personality modules with the older MRM personality modules (typically retrofit installations). This provides for uniform LED operation throughout the installation as MRM's do not directly support external bi-color LED's. SW3-3 should be OFF when using this switch.	LED option	Normal	J4-3 pulses low when either the red or green LED is activated.

\*The improper setting of this switch may cause the reader to behave erratically.

## Setting the Reader Address for RM-4 Personality Modules

The SW1 switch determines the communication address for the readers.

---

**Note** On the RM personality module it is a 16-position rotary switch.

---

Each reader connected to an apC/8X must use 1 through 8 as its address. If SW1 is set to 0 or if SW1 is set between two address numbers, the red LED on the reader flashes rapidly when the reader is turned on.

Setting SW1 to 9 starts a test program when the reader is turned on. This test is explained in Chapter 7.

Each reader must have a unique address on each apC/8X. Assign address numbers to the readers using any convenient sequence, such as the order in which the readers are wired to the apC. For example, set the reader connected to the first apC/8X port (or the first reader on the first multidrop line) to address 1, the reader connected to the second port (or the next reader on the multidrop line) to address 2.

Use a screwdriver to turn the arrow on the switch to the desired address. The system reads the address switch setting after several seconds.

## Installing the Auxiliary Relay Module (ARM-1)

If you are not installing the ARM-1, continue to the next section, “Wiring Inputs to the RM” on page 4-25.

---

**Note** All strike relays **MUST** have a diode or MOV connected as described in this section. Figure 4.7 shows the diode used for a DC door strike, and Figure 4.8 shows the MOV used for an AC door strike. **Do not exceed the contact ratings of the relay!**

---



---

**Note** The ARM-1 (#131-912) uses a logic-driven signal from the RM-4 to drive a 12/24V relay for the door strike.

---



### To install an ARM-1:

---

**Note** To comply with UL294 requirements, the ARM-1 must be installed within a protected area.

---

1. The ARM-1 is 1.7” by 0.75” (4.3 by 1.91 cm) in size. It is mounted inside the protected area no more than 25 ft. (7.6 m) from the RM.
2. Pull in a twisted, shielded pair of 22 AWG (0.357 mm) Belden #9462 between the ARM-1 and the reader personality board. The maximum length for this cable is 25 ft. (7.6 m).
3. Pull in a twisted pair of wires between the ARM-1 and the associated relay controlled device.
4. With the shielded wire, connect Pin 1 of P5 on the RM-4 module to Pin 1 of P2 on the ARM-1. Then connect Pin 2 of P5 on the RM-4 module to pin 2 of P2 on the ARM1.

If you are using a second ARM with your RM, then connect P5-1 on the RM module to P2-1 of the ARM, and P5-3 to P2-2 of the second ARM (Figure 4.10). See Figure 4.12 for the layout of connector P5.

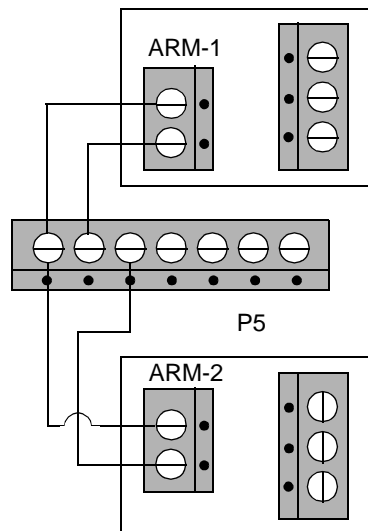
- Wire the ARM-1 to the RM-4 as follows:

ARM #1 - P2-1 to P5-1

P2-2 to P5-2

ARM #2 - P2-1 to P5-1

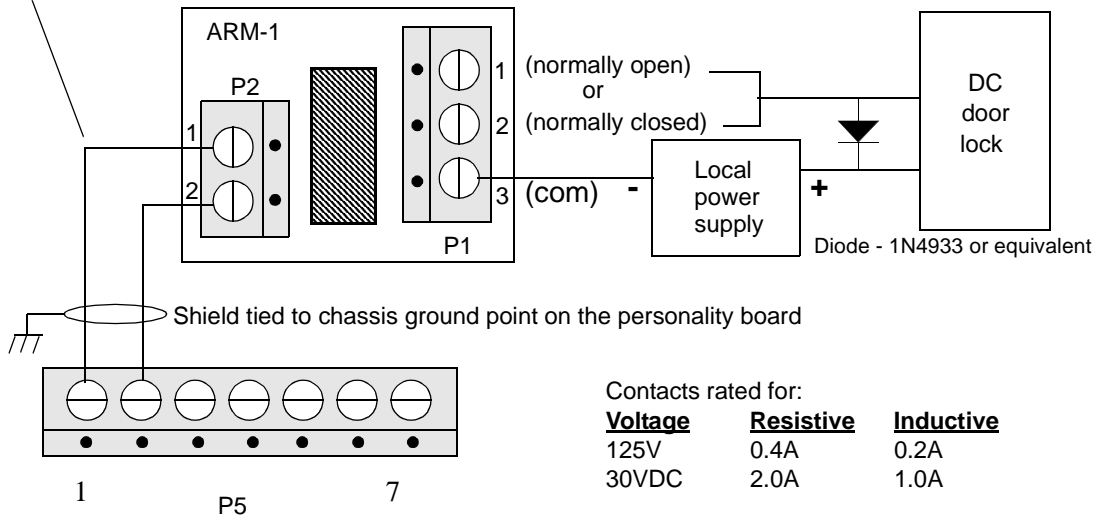
P2-2 to P5-3



**Figure 4.10 Connecting Two ARMs to an RM-4**

5. Connect the second twisted pair to the relay contact terminal connector (C and NO or NC) as required for the controlled device. Connect the other end of the cable to the controlled device itself.
6. If your power supply is DC, install a diode (Motorola or other manufacturer part #1N4933) across the door lock to suppress noise. The cathode must be on the positive side of the strike. The ARM-1 wiring for an installation with DC power is shown in Figure 4.11.

Twisted, shielded 22 AWG (.357mm) Belden #9462, Maximum distance: 25 ft. (7.6 meters)



**Figure 4.11 ARM-1 Wiring for DC Door Lock**

---

**Note** On an RM-4, the pins on P5 are numbered 1- 7.

---



If your power supply is AC, install a varistor (World Products, Inc. part #SNR-D56K2 or equivalent) across the door strike to suppress noise. Figure 4.12 shows the ARM-1 wiring for an installation with AC power.

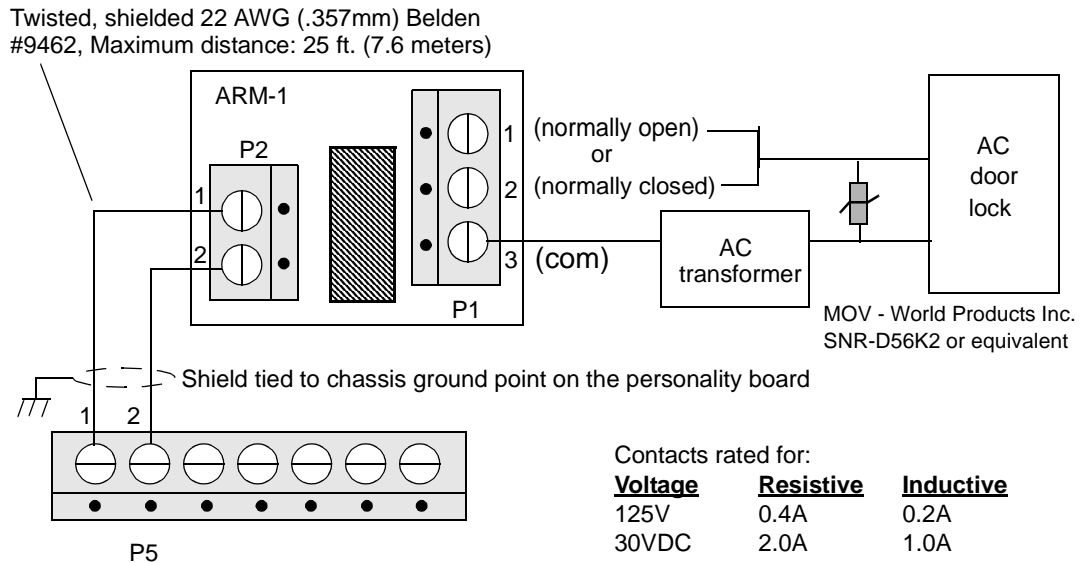


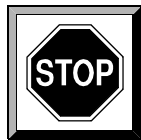
Figure 4.12 ARM-1 Wiring for AC Door Lock

## Wiring for Relay Outputs

To the apC/8X an output is a virtual concept; that is, an output does not have to actually exist, but must be defined to the apC/8X. Relays on the apC/8X are a physical representation of an output.

Pins for eight apC/8X relays are arranged in groups of three on the right side of the main board. On the standard star coupler, the eight relays are organized along the left side and the top. The Wiegand/proximity star coupler and the Mini Star Coupler do not include outputs.

Relay pins are on both the left and right sides of the apC-R/48. The pin orientations differ depending on which side of the board the relay is on. The pins are labelled COM, NC, and NO for common, normally closed, and normally open. They are arranged so you can move a relay connector from one side of the board to the other without rewiring the connector. Use twisted, 18 AWG (0.902 mm) Belden #8461 or twisted 22 AWG (0.357 mm) Belden #8442 for wiring of all relay outputs. For FCC Class B installations, you must use shielded wiring for relay outputs.



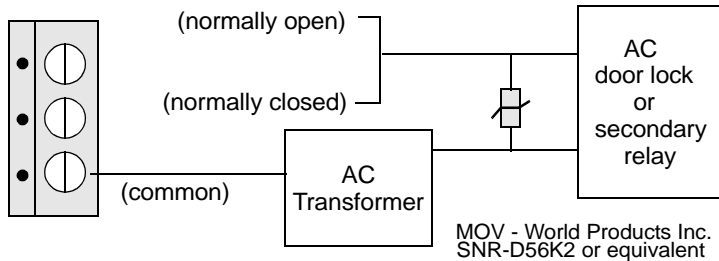
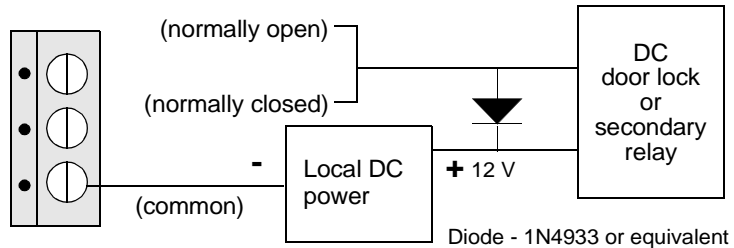
### CAUTION

Do not use apC/8X relays to switch power for a magnetic lock, which exceeds the ratings of the relay contacts shown in Figure 4.13. Use a secondary switching relay instead. All door lock relays must have a diode or MOV connected.

If you are using a relay for a DC locking mechanism or for driving a secondary relay, you must install a diode (Motorola diode type #1N4933 or equivalent) across the lock or relay to suppress noise.

When using a relay for an AC door lock or for driving a secondary relay, you must install a MOV (World Products, Inc. part #SNR-D56K2 or equivalent) across the strike or relay to suppress noise. Figure 4.13 illustrates the diode and MOV installations for door locks.

Relays 1 through 8 are on the main board; 9 through 16 are on the star coupler. Relays 17 through 24 are on the MRM; the card readers activate these relays. See Figure 4.13 for details of wiring the relay outputs.



**Legend**

**All relays except those on the apC/8X motherboard:**

Contacts rated for:

<u>Voltage</u>	<u>Resistive</u>	<u>Inductive</u>
125V	0.4A	0.2A
30VDC	2.0A	1.0A

**Relays on the apC/8X motherboard:**

Contacts rated for:

<u>Voltage</u>	<u>Resistive</u>	<u>Inductive</u>
30VDC/AC*	5A	2.5A

\*The output contacts are protected by 36V MOVs, limiting the connected voltage to 30V.

**Figure 4.13 Connecting the Door Locking Mechanism to a Relay**

**Note** Typically, normally closed = fail-safe strike and normally open = fail-secure strike.

## Determining the Relay Locations for RM Readers

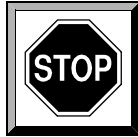
Table 4.3 lists the location and connector number for the relays on RM readers.

**Table 4.3 Relay Location for RM Readers**

Relay #	Location	Connector
17, 121	RM-1	P5-1, P5-2/P5-1, P5-3
18, 122	RM-2	P5-1, P5-2/P5-1, P5-3
19, 123	RM-3	P5-1, P5-2/P5-1, P5-3
20, 124	RM-4	P5-1, P5-2/P5-1, P5-3
21, 125	RM-5	P5-1, P5-2/P5-1, P5-3
22, 126	RM-6	P5-1, P5-2/P5-1, P5-3
23, 127	RM-7	P5-1, P5-2/P5-1, P5-3
24, 128*	RM-8	P5-1, P5-2/P5-1, P5-3

\* This is only for the C•CURE 750.

## Wiring Inputs to the RM



### CAUTION

Improper grounding can result in reader failure or equipment damage. Follow all instructions for grounding to ensure successful operation of your readers.

All input switches can be located up to 2,000 ft. (609.6 m) from the main apC/L module.

Supervised inputs can be either normally open or normally closed. Figure 4.14 shows the wiring for supervised inputs.

Use twisted, 18 AWG (0.902 mm) Belden #8461 or twisted 22 AWG (0.357 mm) Belden #8442 to connect the input switches to the input pins. Place a piece of wire across the screw terminals of any unused active unsupervised inputs.

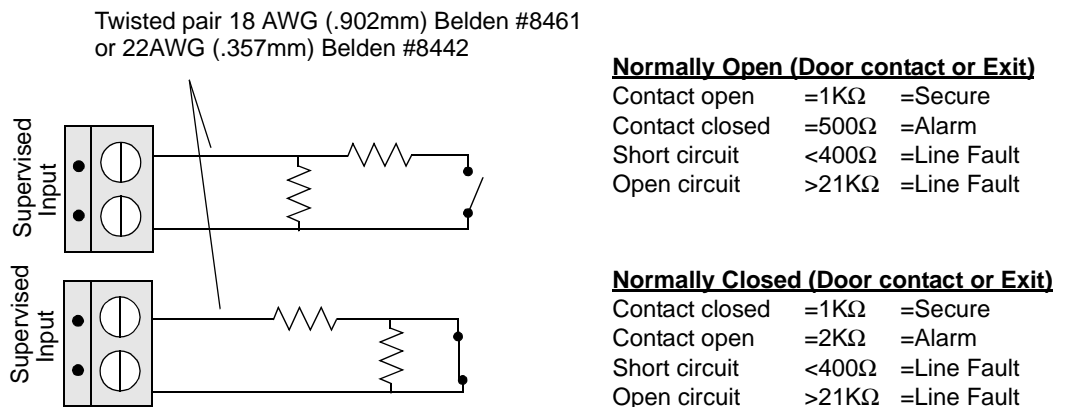


Figure 4.14 Wiring for Supervised Inputs

Other types of inputs are:

- Unsupervised inputs, which are normally closed
- AC power fail input, which is normally closed
- Front and rear tamper switches, which are normally closed

Every input device, including door contacts, exit request inputs, or standard monitoring equipment, has a unique input number determined by the apC/8X pins to which it connects. Input pins are located on the card reader personality modules, the apC I/32 optional module, and the RM Input Module.

---

**Note** FCC Class B Installations require shielded wire.

---

All supervised inputs on the input modules are terminated with on-board 1 K ohm resistors. These resistors stand off the module approximately 0.5". The resistor should be clipped completely out of the module before you use the associated input. Unlike the supervised inputs on the apC, the unsupervised inputs on the standard star coupler have no terminating resistors.

**apC Inputs** IN1 through IN8, corresponding to P9 through P16, are eight supervised inputs (with resistors). The star coupler adds unsupervised inputs IN9 through IN16. The apC/8X supports inputs 17-32 on the personality boards.

Each of the two Wiegand/proximity star coupler modules supplies one supervised input for each reader. Using these eight supervised inputs along with the eight supervised inputs on the apC/8X main board provides a total of two supervised inputs for each reader. Output relays are not provided on the WPSC module set. Instead, use the eight on-board apC/8X relays.

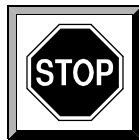
Do not enable inputs 18, 20, 22, 24, 26, 28, 30, and 32 at the host. When enabled, these inputs mirror the input numbered one lower. For instance, a change at input 17 would also be reported as a change at input 18, and a change at input 25 would also be reported as a change on input 26.

**Star Coupler Relays** See System Specific Information F-1 for a list of the input specifications for the apC/8X on the standard star coupler.



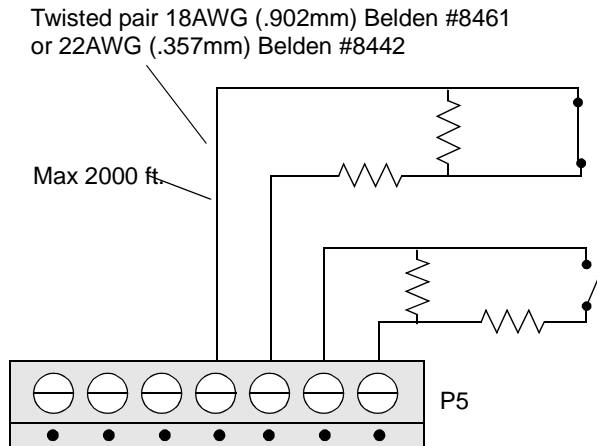
**To wire the RM to the apC/8X:**

1. From the exit push-button and door monitor, pull in a twisted pair, 18AWG (0.902 mm) Belden #8461 or 22AWG (0.357 mm) Belden #8442.



**CAUTION**

See Appendix B of this manual to determine the maximum wire length for readers without an independent power source.



**Normally Closed (Door contact or Exit)**

Contact closed	=1K $\Omega$	=Secure
Contact open	=2K $\Omega$	=Alarm
Short circuit	<400 $\Omega$	=Line Fault
Open circuit	>21K $\Omega$	=Line Fault

**Normally Open (Door contact or Exit)**

Contact open	=1K $\Omega$	=Secure
Contact closed	=500 $\Omega$	=Alarm
Short circuit	<400 $\Omega$	=Line Fault
Open circuit	>21K $\Omega$	=Line Fault

**Note:** If the exit button or door contact is not used, place a 1K ohm resistor across the inputs.

**Figure 4.15 Request to Exit and Door Contact Wiring**

2. If ARMs are used, pull the positive and negative terminal wires. Each should be a shielded twisted pair Belden #9462 with a maximum length of 25 ft. (7.6 m).

### 3. Wiring standard Sensormatic readers.

Remove the reader backplate and feed the wires through the hole in the backplate.

#### Wiring Mullion and Non-Sensormatic Readers

*On the RM:* Plug the reader's sensor wire connector into J3.

These wires may be no longer than 25 ft. for magnetic and 500 ft. for Wiegand readers. Do not run these lines near high voltage lines or motorized equipment (such as elevators or compressors).

---

**Note** Reader data lines and power lines must be separate pairs. Tie the drain wire for the data pair to the earth ground at the apC/8X end only.

---

### 4. Connect the data wires to the pins on the personality board as follows:

- Connect the apC +TXD/+RXD data wire to pin 2 of P1
- Connect the apC -TXD/-RXD data wire to pin 3 of P1
- Do not connect the drain wire at the RM

### 5. Connect the power wires to the pins on the personality board as follows. See Appendix B for information about calculating maximum wire lengths.

- Connect the +12V power line to pin 1 of P1.
- Connect the ground wire to pin 4 of P1.

### 6. If the *door monitor* input is not used, place a 1K ohm resistor across the unused contacts. To use the *door monitor* input, connect the door monitor wires to the pins on the personality board as shown in Figure 4.15.

*For an RM:*

- Connect one lead to pin 4 of P5.
- Connect the other lead to pin 5 of P5



7. If you are not using the *exit push-button* input, place a 1K ohm resistor across the unused contacts. To use the *door monitor* input, connect the exit push-button wires to the pins on the personality board as shown in Figure 4.15.

*For an RM:*

- Connect one lead to pin 6 of P5.
  - Connect the other lead to pin 7 of P5.
8. Connect the reader leads as follows

*For an RM:*

Connect the keypad leads to pins 1-8 of J2. Not all readers use the keypad (J2) terminal

Connect the data leads to pins 1-6 of J3

Connect the LED leads to pins 1-4 of J4. Not all readers use the LED (J4) terminals.

## RM-4 Personality Module with Third Party Reader



### IMPORTANT

All circuit boards are sensitive to electrostatic discharge (ESD). Be careful when installing any board and use the appropriate precautions.

### The RM-4 Personality Module

The RM-4 personality module sets reader characteristics and provides connections to inputs, door strikes, and the apC/L. (See Figure 4.16.) When used with an ARM-1, card readers with an RM-4 personality module provide two supervised inputs and two outputs.

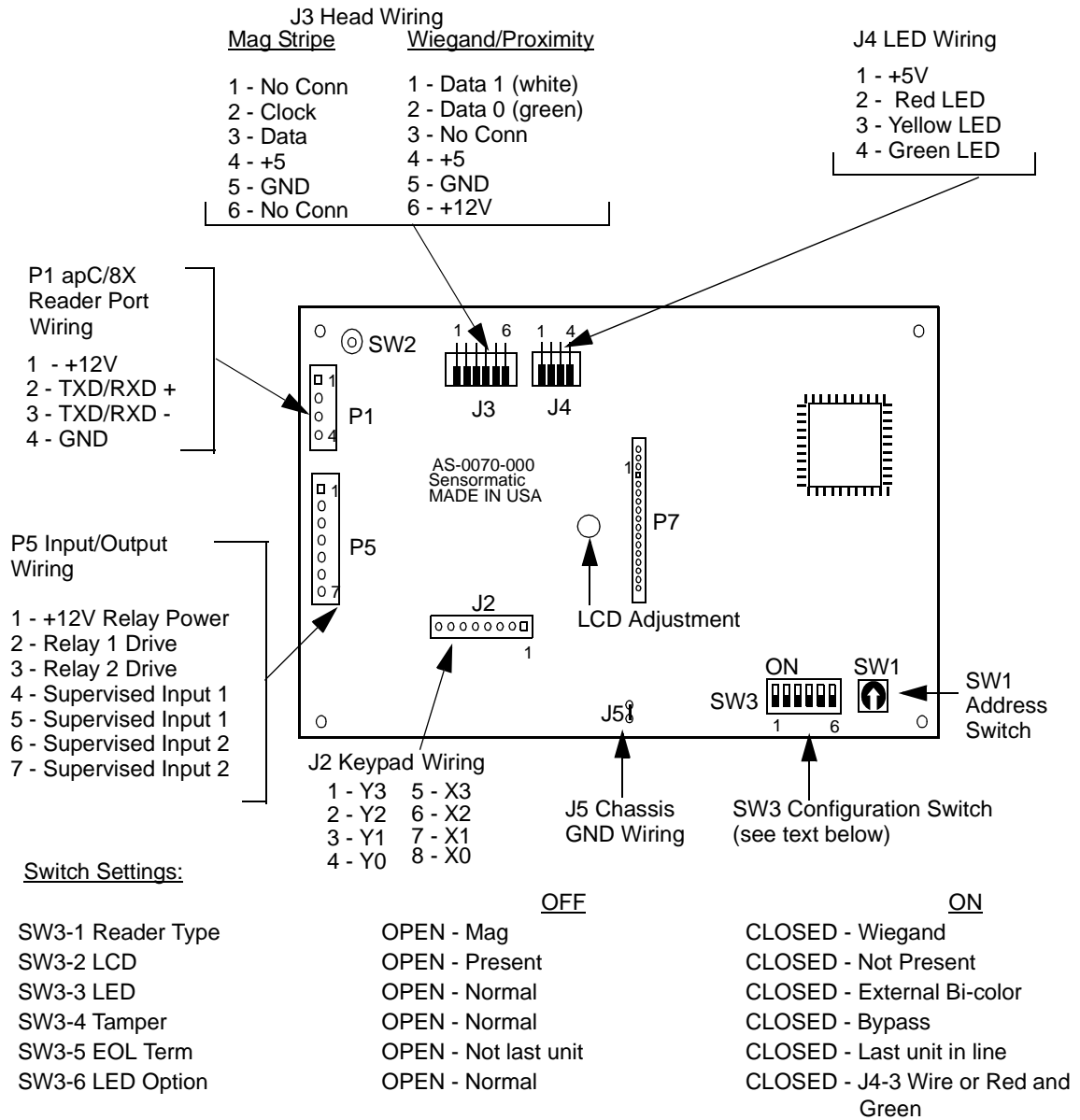
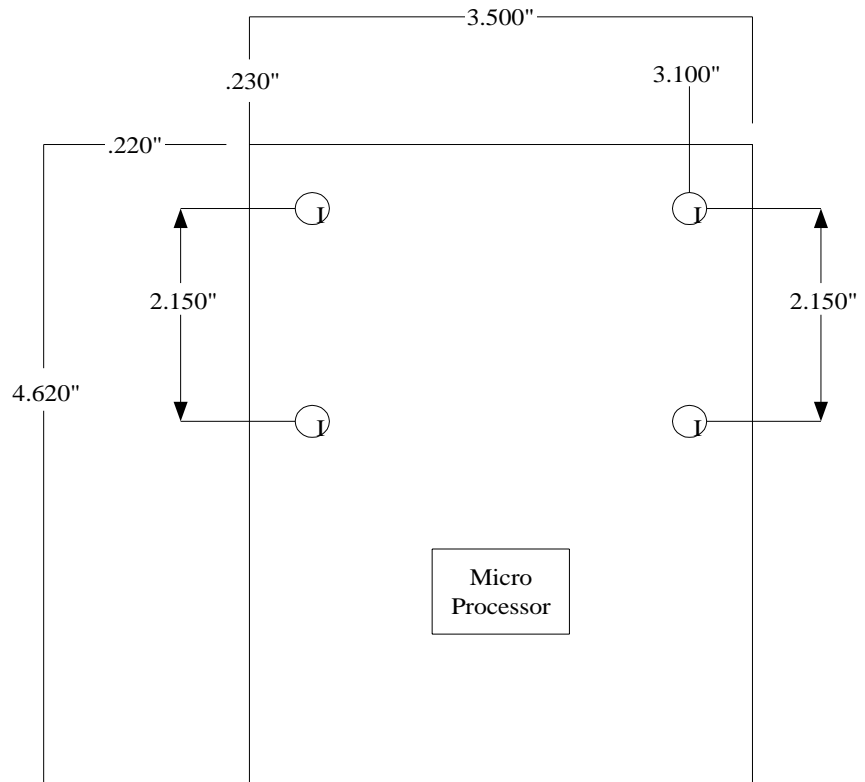


Figure 4.16 RM-4 Personality Module

When you install the RM-4 personality module, make sure it is at least two feet away from any high voltage sources (such as computer monitors or power lines) or motorized equipment (such as elevators or compressors).

Figure 4.17 illustrates mounting specifications in inches for the newest RM-4 personality board.



**Legend - Hole Size**  
I = .125

**Figure 4.17 Mounting Specifications for the RM-4 Personality Module**

**To install the RM-4 module in the junction box:**

1. Insert metal standoffs (not supplied) in the module's screw holes and mount the module to the box.
2. Use 3/16" diameter round M/F 4-40 standoffs, with lengths appropriate to your installation. For example, Globe part #A-6701-440 is an acceptable 1/4" standoff.

---

**Note** Ensure that the mounting hole nearest the grounding lug (J5) of the RM-4 is grounded to a proper earth ground or ground directly to lug J5. See Figure 4.17.

---

**Installing the RM1 or RM2 Reader Assembly**

**Sensormatic readers** The RM-4 is already installed in the reader body of Sensormatic RM-1 and RM-2 readers when they are shipped.

**Non-Sensormatic readers** For non-Sensormatic Wiegand readers such as Sensor Readers, install the RM-4 in a 6" x 4" (minimum) metal, grounded junction box no more than 500 ft. from the read head.

**Magnetic stripe Mullion reader** Install the RM-4 for a magnetic stripe mullion reader RM-3 in a grounded, metal 6" x 4" (minimum) junction box no more than 25 ft. (3.05 m) from the read head.

**CAUTION**

Do not apply power to any equipment while it is being installed. Apply power only after all procedures in this chapter are completed, and the system is ready for testing. Failure to follow this warning could result in damage to equipment, personal injury, or death.



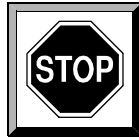
**To install a reader assembly:**

1. Secure the reader backplate and gasket to the junction box with the four mounting screws.

When RM readers are installed outdoors, the foam gasket forms a weather seal.

2. Align all holes in the gasket with the holes in the backplate. Leave an equal amount of gasket overlap on all sides of the plate.

If the reader is located in a high-static area or if it is not connected to a grounded circuit, run a ground strap from the reader backplate to a local AC ground or cold water pipe. Use as short a wire as possible.



**CAUTION**

Outdoor readers **MUST** be installed in a vertical position to allow for proper drainage. Install a fitted gasket between the backing plate of these readers and the wall. Ensure that the “weep” holes in the bottom of the housing are unobstructed.

---

**Note** In outdoor readers exposed to driving rain, the circuit boards must be coated with conformal coating. For this type of application, Sensormatic can provide pre-coated circuit boards. For details and cost, contact Sensormatic.

---

3. Hook the top of the reader over the top of the backplate, and press the reader firmly against it.
4. Use a security screwdriver (part #132-183) to install the two security screws in the bottom of the reader.

## Installing the RM-4 Personality Module



### To install a third-party reader:

1. For non-Sensormatic Wiegand readers such as Sensor Readers, install the RM-4 in a grounded 6" x 4" (minimum) metal junction box no more than 25 ft. from the read head.
2. Remove the knockout plugs from the junction box.
3. Install the box in the desired location, and attach the conduits.
4. Install the RM-4 module using metal standoffs and screws.
5. Earth grounding the board is required to reduce electrical noise in the circuit. To ground the board to the box, either make a connection from lug J5 to earth ground or use a metal standoff and screw in the mounting hole next to C2 and V4 (the voltage regulator).
6. Make sure that the connection is continuous to the box. See Figure 4.16 for the location of the grounding lug J5.



### To install a magnetic stripe Mullion reader:

1. Install the RM-4 for a magnetic stripe Mullion reader RM-3 in a grounded, 6" x 4" (minimum) metal junction box no more than 10 ft. (3.05 m) from the read head.
2. Install the box in the desired location and attach the conduits.

If you must install the board in the door frame instead, cut a hole in the mullion to accommodate the reader wiring, then install the reader backplate over the hole.

3. Mount the RM-4 board with screws and standoffs.
4. To ground the board to the box, either make a connection from lug J5 to earth ground or use a metal standoff and screw in the lower right mounting hole. Make sure that the connection is continuous to the box. See Figure 4.16 for the location of the grounding lug J5.

## Optional Heater Kit

If the reader is installed outdoors, a thermostatically controlled heater (part #130-915 or 130-915A) may be necessary. The 130-915 heater kit is supplied with a 12V AC, 40VA transformer for operation on 110V AC. The heater switches on at 40° F.

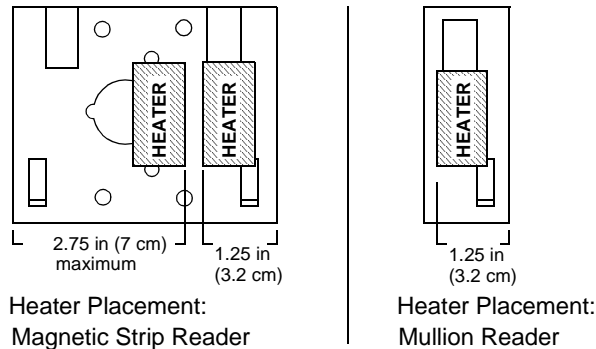


### **IMPORTANT**

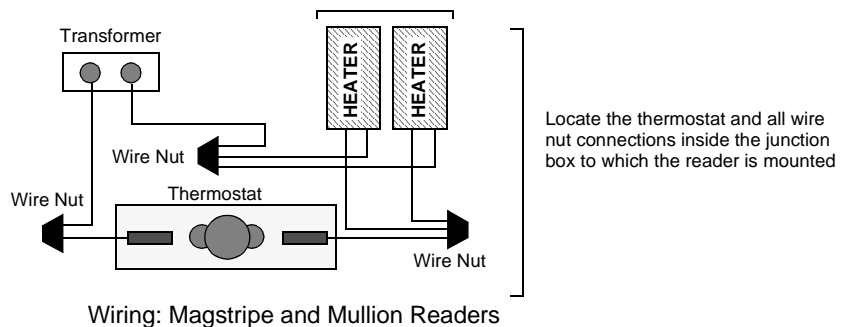
The heater kit requires a separate power supply. Do not use the reader or apC/8X power supply for a heater kit. Use Belden 8442/8462 wire for connecting the transformer to the thermostat/heater strip.



**Standard Magnetic and Mullion Readers** The current draw for each strip is 1.25 A at 12V. Figure 4.18 illustrates heater placement for these readers.



Heater strips: Use 1 strip for Mullion reader.  
Use 2 strips for mag stripe reader.



**Figure 4.18 Heater Installation for Standard Magnetic Stripe and Mullion Reader**



### Installing a thermostatically controlled heater:

1. Remove the backing from the double-sided adhesive tape on the heater strips. Firmly press the strips onto the inside of the backplate (see Figure 4.18).
2. Feed the heater wires through the hole in the backplate.

3. Connect the wires from the 12V transformer and the thermostat using the wrenuts provided.
4. Locate the thermostat in close proximity to the heater strip(s) so that the reader does not overheat.

---

**Note** The thermostat is designed to turn off the heater strip(s) at approximately 60° F. Locating the thermostat anywhere but in the junction box to which the reader is mounted can damage the strips and/or the reader.

---

See "Templates and Technical Drawings" in Appendix E for a diagram.

**Wiegand and proximity readers** Wiegand/proximity read heads attached to RMs require no heater. The manufacturer specifies operating temperatures.

For Sensormatic RM magnetic read heads, heaters are required if the reader is mounted in an area where the ambient temperature falls below 32° F (0° C).

## CHAPTER 5



# Input and Output Modules

This chapter describes the optional modules and how to wire them.

### In This Chapter

---

- Overview 5-2
- Installing the Star or Mini Star Couplers 5-3
- Installing the Wiegand/Proximity Star Coupler (WPSC) 5-5
- Installing the apC-I/32 Supervised Input Module 5-7
- Installing the apC-R/48 Relay Module 5-11
- Setting Up Relays 5-14
- The RM Optional Modules 5-19
- Installing Optional Modules 5-22

## Overview

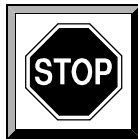
---

**Note** The C•CURE 1 Plus Ultra, C•CURE 750, and C•CURE 800 systems support these modules. Make sure your apC/8X firmware is at Version 8.4F or later.

---

Mount the optional modules as follows:

- R/48 Relay Module - next to the apC/8X.
- R-I/32 Supervised Input Module, standard, mini, and Wiegand/proximity star couplers - on top of the main apC/8X board, using standoffs. These modules connect to the P17 option bus connector on the apC/8X.
- RM Input and Output modules - attach to the reader bus.



### CAUTION

Make sure the power is off before you add or remove any module on the apC/8X.

All circuit boards are sensitive to electrostatic discharge (ESD). Be careful when installing any module and use the appropriate precautions.

# Installing the Star or Mini Star Couplers

Refer to Figure 5.1 to while performing the installation.

Expander Board:

- Star Coupler
- Mini Star Coupler
- Wiegand/Prox. Star Coupler

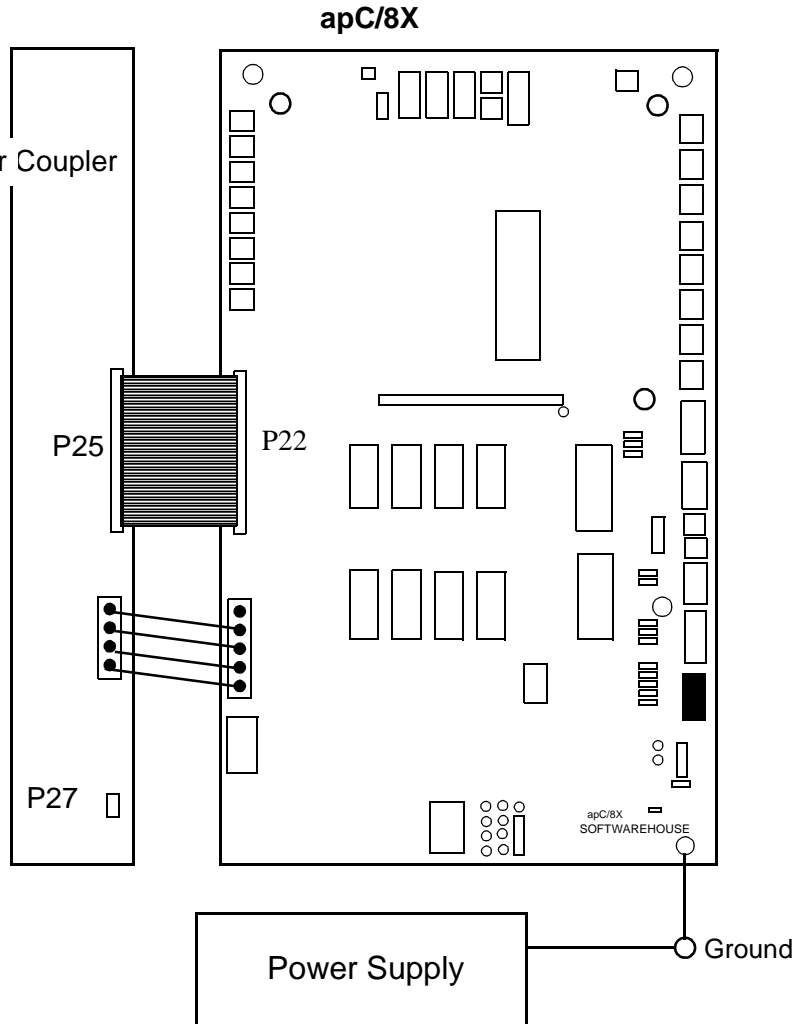
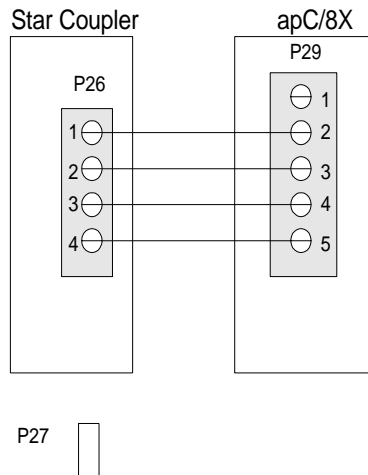


Figure 5.1 Star, Mini Star and WPSC Connections

**Installing a star or mini star coupler:**

1. After removing any power to the apC/8X, place the star coupler over the standoffs in the cabinet. The cable assembly should be facing the main apC/8X board.
2. Using the six screws provided, secure the star coupler in place.
3. Insert the cable connector into P22 of the apC/8X.
4. Attach the power connector provided, using P29 on the apC/8X, pins 1 through 5.
5. Attach one end of the chassis ground wire to the lug at P27 of the star coupler.

**Figure 5.2 Attaching Chassis Ground Wire to Lug at P27**

6. Attach the other end of the chassis ground wire to the chassis ground screw, located on the cabinet to the right of the power supply.

## Installing the Wiegand/Proximity Star Coupler (WPSC)

The Sensormatic Wiegand/Proximity Star Coupler (WPSC) allows direct connection of up to eight Wiegand output card readers. The WPSC module is a two board set that attaches to the same bus connector as the standard star coupler. Thus, you cannot use both a WPSC and standard star coupler on the same apC/8X.

The WPSC lower module (AS-0054-000) supports up to four Wiegand or proximity readers. An optional upper module (AS-0054-001) supports up to four additional readers.

Refer to Figure 5.1 while performing this installation procedure.



### Installing a WSPC module:

1. Attach the lower module to the apC/8X cabinet using six standoffs.
2. Connect the WPSC lower module connectors to the apC/8X connectors as follows.

WPSC Lower module Connector	apC/8X Connector
P12	P22 (64-pin bus connector)
P13	P29
P10	Chassis ground connector

3. Install the optional upper module by using four standoffs to mount it on the top part of the main apC/8X board.

4. Plug P15 of the optional upper module into P11 of the lower WPSC module. (See Figure 5.3).

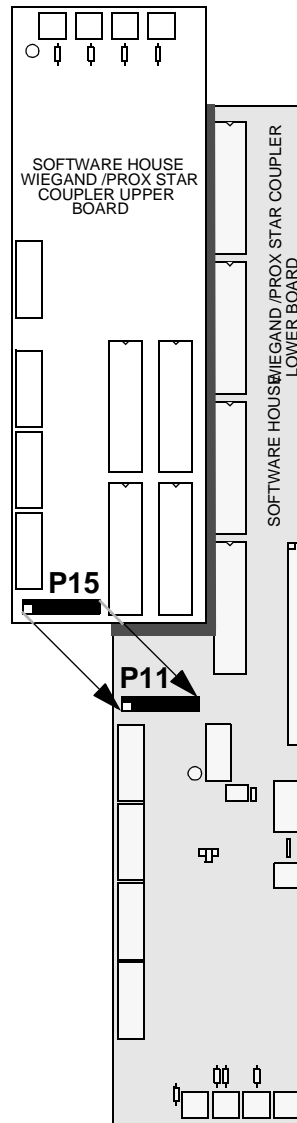


Figure 5.3 Pin Connections for Lower WPSC Board



## Installing the apC-I/32 Supervised Input Module

The apC-I/32 mounts directly on the main apC/8X board through the option bus connector (P17); or, if you have apC-R/48 boards installed, the apC-I/32 mounts on the outermost apC-R/48 through the P49 connector. Each apC-I/32 comes with the following mounting hardware.

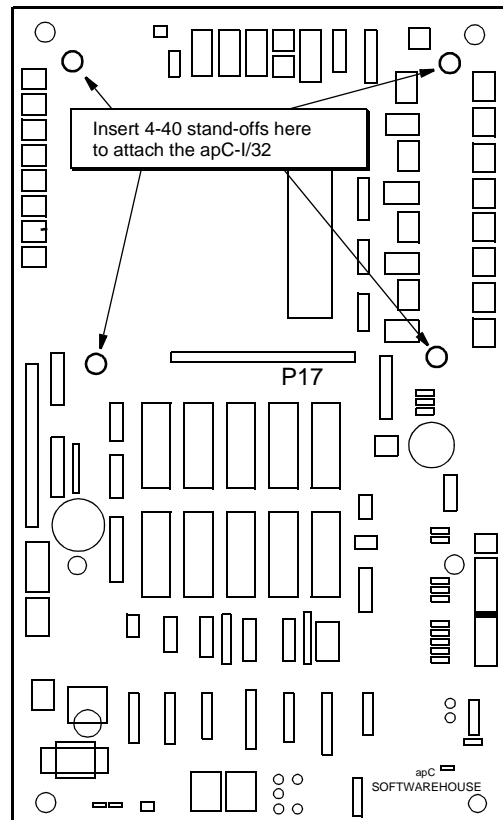
- 4 spacers: M/F 4-40, 1/4 Hex X 3/4
- 4 nuts: 4-40 X 1/4
- 4 screws: 4-40 X/14
- 4 star washers: #4 external

See Figures 5.4 and 5.5 while performing this installation.



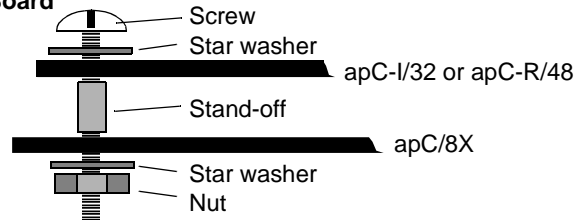
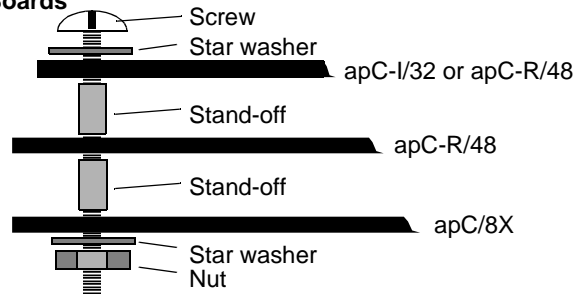
### **Installing an apC-I/32 Input module:**

1. If you are installing the apC-I/32 on a previously installed apC/8X without option boards, unbolt the main apC/8X board from the six standoffs that fasten it to the cabinet.
2. If you are installing the apC-I/32 on an apC/8X with a previously installed apC-R/48 module, you need not remove the main apC/8X board from the cabinet. Rather, remove the top four screws and star washers that fasten the apC/8X board to the cabinet, and replace them with apC-I/32 standoffs.
3. Attach the four standoffs to the apC/8X main board by inserting the threaded end of the standoffs into the holes shown in Figure 5.4.

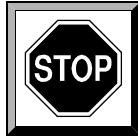


**Figure 5.4 Standoff Locations for Mounting the apC-1/32**

4. Place a star washer over the threaded end of the standoff, and secure the standoff to the module with the 4-40 nut. **Do not overtighten!**
5. Bolt the main apC/8X board to the cabinet with the original screws and standoffs. (See Figure 5.5.)

**Mounting 1 Option Board****Mounting 2 Option Boards****Figure 5.5 Mounting Option Modules With Standoffs**

6. Align the mounting holes and bus connectors on P33 of the apC-I/32 and P17 on the main apC/8X board.
7. Carefully plug the apC-I/32 into the option bus connector (P17) on the main apC/8X board.
8. Finish attaching the apC-I/32 to the standoffs using the star washers and screws provided.
9. Wire the supervised inputs as described in Chapter 4.



## CAUTION

Make sure you mount the module right side up. If correctly mounted, the mounting holes on the modules align and the cutouts along the top of the module allow access to the switches and LED bar of the apC/8X. (See Figure 5.4 for the correct position.)

The connector is preset for the normal position.

Ensure that all pins make contact with the connector before tightening down the apC-I/32 with the star washers and screws.

## Removing a Supervised Input module

If you remove a supervised input module from the apC/8X, external voltages present on the input lines may cause damage to the supervised input module if the ground reference is removed from the module.



### Guarding against damage when you remove a module:

1. Shut down all power from the apC/8X.
2. Unplug all monitor point wiring connectors from the expansion module.
3. Unplug the expansion module from the main board.

## Installing the apC-R/48 Relay Module

You can install two apC-R/48 relay modules on a single apC/8X. The first apC-R/48 mounts directly on the main apC/8X module through the option bus connector, P17. Set jumper W1 on the first apC-R/48 to position A.

If you use a second apC-R/48, mount it on P49 of the first apC-R/48. Set jumper W1 on the second apC-R/48 to position B. Each comes with the following hardware.

- 6 standoffs: M/F 4-40, 1/4 Hex X 3/4
- 2 standoffs: M/F 6-32, 1/4 Hex X 3/4
- 6 nuts: 4-40 X 1/4
- 2 nuts: 6-32 X 1/4
- 6 screws: 4-40 X 1/4
- 2 screws: 6-32 X 1/4
- 6 star washers: #4 external
- 2 star washers: #6 external
- 1 64-pin dual row connector: Installed on the bottom of the R/48



### Installing the R/48 module to the 8 mounting holes on the apC/8X:

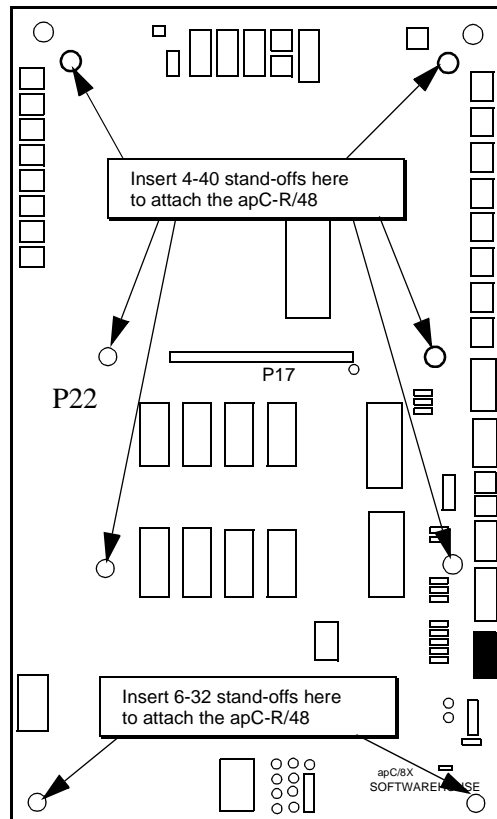
1. If you are installing the apC-R/48 on a previously installed apC/8X without option boards, unbolt the apC/8X main board from the six standoffs that fasten it to the cabinet. See Figure 5.6.
2. If you are installing the apC-R/48 on an apC/8X with a previously installed apC-R/48, you need not remove the apC/8X main board from the cabinet. Rather, remove the top eight screws and star washers holding down the apC-R/48, and replace them with the second apC-R/48's standoffs.

---

**Note** W1 on the apC-R/48 determines whether the module will respond as the first or second apC-R/48. For the first apC-R/48, set jumper W1 to A position. For the second apC-R/48, set jumper W1 to B position.

---

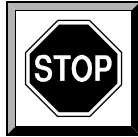
- Attach the six 4-40 standoffs to the main apC/8X board by inserting the threaded end of the standoffs into the holes indicated in Figure 5.6. Place a star washer over the threaded end of the standoff and secure the standoff to the module with the 4-40 nut. **Do not overtighten!**



**Figure 5.6 Standoff Locations for Mounting the apC-R/48**

- Bolt the main apC/8X board to the cabinet with the original screws and standoffs, except for the two bottom mounting holes. In the bottom two holes, screw in the 6-32 standoffs instead of replacing the original screws.
- Align the mounting holes and bus connectors of P49 of the apC-R/48 and P17 of the apC/8X main board.

6. Carefully plug the apC-R/48 into the option bus connector (P17) on the apC/8X main board.
7. Finish attaching the apC-R/48 to the standoffs by using the star washers and screws provided.



## CAUTION

Make sure you mount the module right side up. If correctly mounted, the mounting holes on the modules align and the cutouts along the top of the module allow access to the switches and LED bar of the apC/8X.

The connector is preset for the normal position.

Ensure that all pins make contact with the connector before tightening down the apC-R/48 with the star washers and screws.

## Setting Up Relays

This section contains tables for setting up your relay locations. Table 5.1 lists the relay locations and output numbering for an apC/8X using a standard star or Wiegand/proximity star coupler.

**Table 5.1 Relay Locations and Output Numbering for apC/8X with Standard Star Coupler or Wiegand/Proximity Star Coupler<sup>1</sup>**

Relay #	Location	Connector	Elevator Control?	Relay #	Location	Connector	Elevator Control?
1	apC/8X	P1	Yes	17	Reader 1	P5 (Relay 1)	No
2	apC/8X	P2	Yes	18	Reader 2	P5 (Relay 1)	No
3	apC/8X	P3	Yes	19	Reader 3	P5 (Relay 1)	No
4	apC/8X	P4	Yes	20	Reader 4	P5 (Relay 1)	No
5	apC/8X	P5	Yes	21	Reader 5	P5 (Relay 1)	No
6	apC/8X	P6	Yes	22	Reader 6	P5 (Relay 1)	No
7	apC/8X	P7	Yes	23	Reader 7	P5 (Relay 1)	No
8	apC/8X	P8	Yes	24	Reader 8	P5 (Relay 1)	No
9	Star coupler	P1	Yes				
10	Star coupler	P2	Yes				
11	Star coupler	P3	Yes				
12	Star coupler	P4	Yes				
13	Star coupler	P5	Yes				
14	Star coupler	P6	Yes				
15	Star coupler	P7	Yes				
16	Star coupler	P8	Yes				

<sup>1</sup>Relays 9-24 are unavailable when using a Wiegand/Proximity star coupler.

---

**Note** If you are using the RM Input and Output Modules for elevator control, see Appendix F for information about numbering.

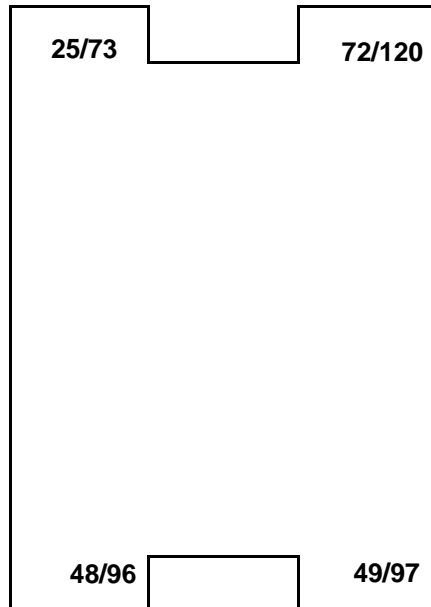
---



## R/48 Relays

Each apC R/48 module installed on the apC/8X adds 48 additional relays. You can have two of these modules. Relays on the first apC R/48 are numbered 25-72. Relays on the second module are numbered 73-120.

You can use all apC R/48 relays for elevator control, in which case relays start at 17. Figure 5.7 show relay locations on the R/48 module.



**Figure 5.7 R/48 Relays**

Table 5.2 indicates the relay number and connector for each output on the module.

**Table 5.2 Relay Specifications for R/48 modules 1 and 2 (Outputs)  
Connecting Inputs**

Relay #	Location	Connector	Relay #	Location	Connector
25	Board #1	P1	47	Board #1	P23
26	Board #1	P2	48	Board #1	P24
27	Board #1	P3	49	Board #1	P25
28	Board #1	P4	50	Board #1	P26
29	Board #1	P5	51	Board #1	P27
30	Board #1	P6	52	Board #1	P28
31	Board #1	P7	53	Board #1	P29
32	Board #1	P8	54	Board #1	P30
33	Board #1	P9	55	Board #1	P31
34	Board #1	P10	56	Board #1	P32
35	Board #1	P11	57	Board #1	P33
36	Board #1	P12	58	Board #1	P34
37	Board #1	P13	59	Board #1	P35
38	Board #1	P14	60	Board #1	P36
39	Board #1	P15	61	Board #1	P37
40	Board #1	P16	62	Board #1	P38
41	Board #1	P17	63	Board #1	P39
42	Board #1	P18	64	Board #1	P40
43	Board #1	P19	65	Board #1	P41
44	Board #1	P20	66	Board #1	P42
45	Board #1	P21	67	Board #1	P43
46	Board #1	P22	68	Board #1	P44

**Table 5.2 Relay Specifications for R/48 modules 1 and 2 (Outputs)  
Connecting Inputs**

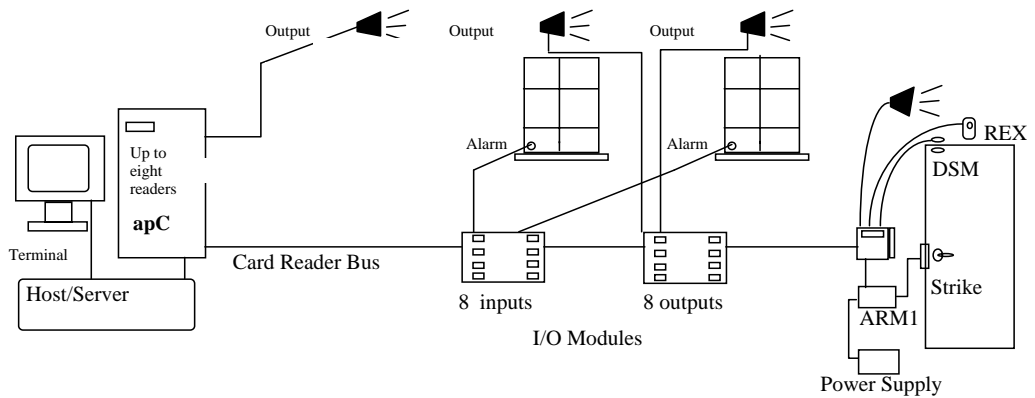
Relay #	Location	Connector	Relay #	Location	Connector
69	Board #1	P45	92	Board #2	P20
70	Board #1	P46	93	Board #2	P21
71	Board #1	P47	94	Board #2	P22
72	Board #1	P48	95	Board #2	P23
73	Board #2	P1	96	Board #2	P24
74	Board #2	P2	97	Board #2	P25
75	Board #2	P3	98	Board #2	P26
76	Board #2	P4	99	Board #2	P27
77	Board #2	P5	100	Board #2	P28
78	Board #2	P6	101	Board #2	P29
79	Board #2	P7	102	Board #2	P30
80	Board #2	P8	103	Board #2	P31
81	Board #2	P9	104	Board #2	P32
82	Board #2	P10	105	Board #2	P33
83	Board #2	P11	106	Board #2	P34
84	Board #2	P12	107	Board #2	P35
85	Board #2	P13	108	Board #2	P36
86	Board #2	P14	109	Board #2	P37
87	Board #2	P15	110	Board #2	P38
88	Board #2	P16	111	Board #2	P39
89	Board #2	P17	112	Board #2	P40
90	Board #2	P18	113	Board #2	P41

**Table 5.2 Relay Specifications for R/48 modules 1 and 2 (Outputs)  
Connecting Inputs**

Relay #	Location	Connector	Relay #	Location	Connector
91	Board #2	P19	114	Board #2	P42
115	Board #2	P43			
116	Board #2	P44			
117	Board #2	P45			
118	Board #2	P46			
119	Board #2	P47			
120	Board #2	P48			

## The RM Optional Modules

Figure 5.8 shows how you might set up and wire your optional modules.

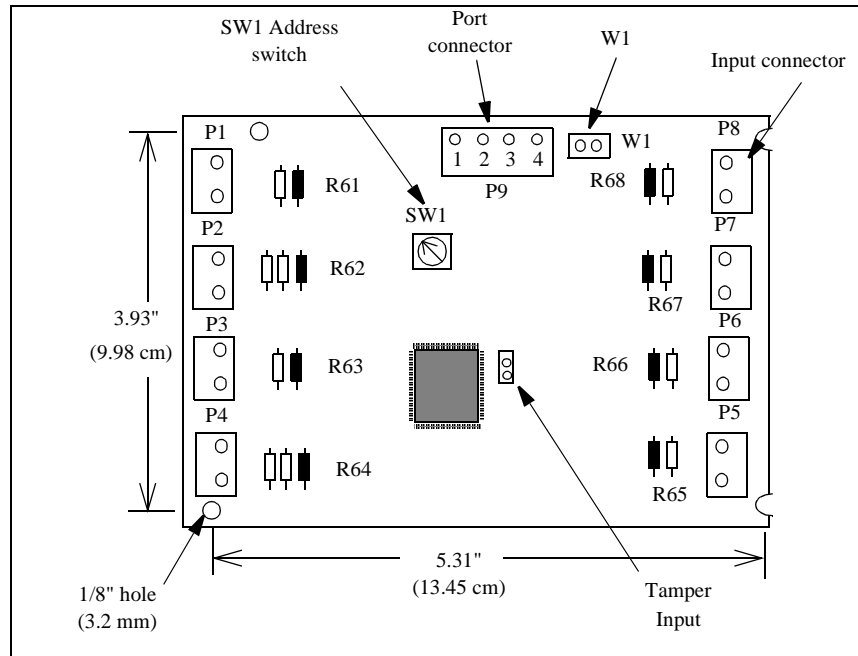


**Figure 5.8 Sample I/O Module Setup**

### I8 Input Module

The apC-I/8 Module (or *RM Input Module*) provides eight Class A supervised inputs. You can connect a total of eight Input Modules to one apC. RM Input Modules connect directly to the RS-485 line for the reader, which reduces wiring.

Figure 5.9 shows the layout of an RM Input Module.



**Figure 5.9 apC/8X Input Module**

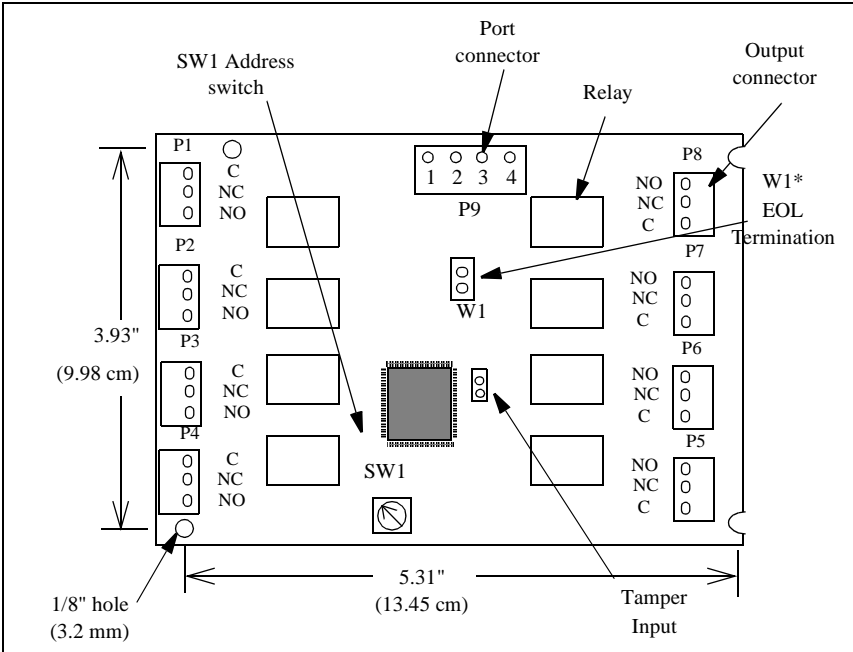
All input switches can be located up to 2,000 ft. (600 m) from the Input Module. Use twisted 18 AWG (0.902 mm) Belden #8461 or twisted 22 AWG (0.357) Belden #8442 to connect the input switches to the input pins.

All supervised inputs on the Input Module are terminated with on-board 1K ohm resistors. These resistors stand off the module approximately 1/4" (6 mm) Before you use the associated input, clip the resistor out completely.

### apC-R8 Output Bus Module

The apC-R/8 Output Bus Module (or *RM Output Module*), provides eight outputs. You can install a total of eight Output Modules on one apC/8X. Like Input Modules, Output Modules connect directly to the RS-485 line for the reader.

Figure 5.10 shows the layout of an Output Module.



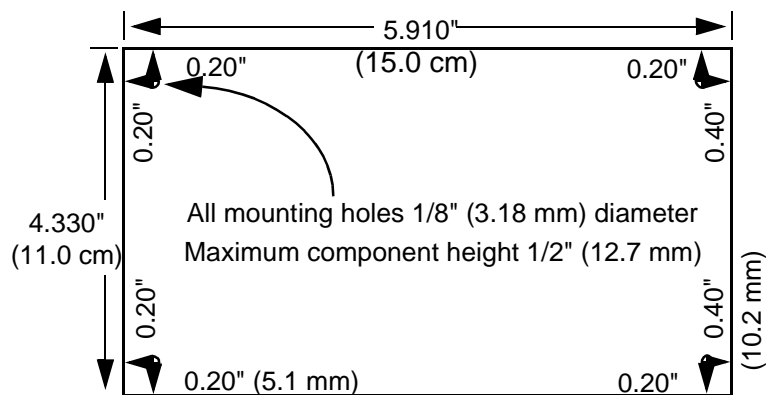
\*W1 should be closed only on the last board of an RS-485 loop. Remove and store the jumper on intermediate boards.

Figure 5.10 apC/8X Output Module

## Installing Optional Modules

You install the optional modules on the reader bus, just as you would install a reader. The mounting slot in each corner serves as a connection for earth ground. Make sure at least one corner is tied to earth ground.

**Input and Output Board Dimensions** Figure 5.11 shows the overall dimensions of the input board. Note that all mounting holes are 1/8" (3.18 mm) in diameter.



**Figure 5.11 Input/Output Module Dimensions**

**Hardware Address** When installing input boards, set the first board to address one, then set the next board(s) addresses in sequence. Do not skip any address switch positions. For example, install the first board with address 1, the second board with address 2, and the third board with address 3.

If you skip addresses, for example using addresses 1, 2, and 5 on an apC/8X configured to have 24 input board monitor points, your system will incorrectly report on the monitor points associated with the boards. In this example, the system will correctly report on points associated with the first 16 monitor points. However, the system will report that the last eight monitor points are always secure, regardless of the actual status of points on the third board (which has address 5.)



To configure monitor points for address 5, you must configure the apC/8X for 40 input board control points.

**Wiring** The wiring for the input board on P9 is the same as for an RM unit:

- Pin 1: +12VDC
- Pin 2: +TXD/RXD
- Pin 3: -TXD/RXD
- Pin 4: GND

If you already use all eight card reader ports, you can bus an input board on an existing run. Be sure to stay within the allowable maximum wire length of 4,000 ft. (1,219.2 m).

Install the end-of-line terminator on the last physical device on the bussed run. For input boards, this is W1.

Connect no more than eight input boards to an apC/8X. Each input board must have a unique address.

**Wire Type and Length** The input board has the same wiring restrictions as RM devices.

**Power Requirements** Each input board has a typical rating of 125mA at 12VDC. You can calculate at what point you need to add external power based on the current draw of other boards in your system and the current available from your power supply. The apC/8X power supply provides 3.3 amperes at 12 VDC.

**Addressing** Each input board has a rotary switch that you set to addresses 1 through 8. These addresses do not interfere with card reader or output board addresses.

**Tamper Switch** You can wire an external switch to the two-pin header labeled TAMPER to provide a tamper indication. The switch should be normally closed when the tamper is secure. Sensormatic delivers the boards with TAMPER jumpered. This default forces a secure condition. You can link TAMPER to a logical monitor point to cause an alarm condition.

**Termination Resistors** Each input board comes with eight 1K termination resistors installed approximately 0.25" above the PC board. Cut these resistors as you wire the individual inputs into your system. The resistors are numbered R61 through R68, corresponding to inputs one through eight respectively.

You must install End-of-Line (EOL) resistors at the sensing device location. See Chapter 4 of this manual for further information.

**Enclosures** Sensormatic has identified two enclosure types (with NEMA/CEMA 4, 4X, 12, and 13 ratings, and IEC 529 rating IP66-11) from the following vendor as compatible with the input board footprints:

Vynckier  
249 McCarty Drive  
Houston, TX 77029  
713-672-2471 Fax 800-444-1261

Model Number	Size in Inches	Size in cm.	Description
14321.000	H = 6.89 W = 6.89 D = 2.95	H = 17.5 W = 17.5 D = 7.5	Clear cover with knockouts
14321.060	H = 6.89 W = 6.89 D = 2.95	H = 17.5 W = 17.5 D = 7.5	Clear cover without knockouts
14321.500	H = 6.89 W = 6.89 D = 2.95	H = 17.5 W = 17.5 D = 7.5	Solid cover with knockouts
14321.560	H = 6.89 W = 6.89 D = 2.95	H = 17.5 W = 17.5 D = 7.5	Solid cover without knockouts
14321.201	H = 6.89 W = 6.89 D = 2.95	H = 17.5 W = 17.5 D = 7.5	Steel backplate for all preceding modules

Model Number	Size in Inches	Size in cm.	Description
3500.00	H = 9.84 W = 6.89 D = 5.91	H = 25 W = 17.5 D = 15	Clear cover with knockouts
3000.000	H = 9.84 W = 6.89 D = 5.91	H = 25 W = 17.5 D = 15	Solid cover with knockouts
3500.201	H = 9.84 W = 6.89 D = 5.91	H = 25 W = 17.5 D = 15	Back panel

## Output Board Installation

**Output Board Dimensions** Figure 5.11 shows the overall dimensions of the output board. Note that all mounting holes are 1/8" (3.175 mm) in diameter.

**Hardware Address** When installing output boards, set the first board to address one, then set the next board(s) addresses in sequence. Do not skip any address switch positions. For example, install the first board with address one, the second board with address two, and the third board with address three.

If you skip output board addresses, for example using addresses one, two, and five on an apC/8X configured to have 24 output board control points, the C•CURE 1 Plus Ultra will disregard control points at address number five. In this example, the system will correctly activate and download the first 16 control points. To configure control points for address number five, you must configure the apC/8X for 40 output board control points.

**Wiring** The wiring for the output board on P9 is identical to an RM:

- Pin 1: +12VDC
- Pin 2: +TXD/RXD
- Pin 3: -TXD/RXD
- Pin 4: GND

If you already use all eight card reader ports, you can bus an output board on an existing run. Be sure to stay within the allowable maximum wire length of 4,000 ft. (1,219.2 m). Install the end-of-line terminator on the last physical device on the bussed run. For output boards, this is W1.

Connect no more than eight output boards to an apC/8X. Each output board must have a unique address.

**Wire Type and Length** The output board has the same wiring restrictions as RM devices.

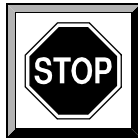
**Power Requirements** Each output board has a typical rating of 125mA at 12VDC, plus another 25 mA for each active relay. You can calculate at what point you need to add external power based on the current draw of other boards in your system and the current available from your power supply. The apC/8X power supply provides 3.3 Amperes at 12 VDC.

**Addressing** Each output board has a rotary switch that you set to addresses one through eight. These addresses do not interfere with card reader or input board addresses.

**Tamper Switch** You can wire an external switch to the two-pin header labeled TAMPER to provide a tamper indication. The switch should be normally closed when the tamper is secure. Sensormatic delivers the boards with TAMPER jumpered. This default forces a secure condition. You can link TAMPER to a logical monitor point to cause an alarm condition.

**Door Strike Relay Ratings** Contact relays for the output boards are rated as follows.

Voltage	Resistive	Inductive
125 V	0.4A	0.2A
30 V DC/AC	2.0 A	1.0 A



### CAUTION

Do not use apC/8X relays to switch power for a magnetic lock exceeding the ratings of the relay contacts shown here. Instead, use an external switching relay.

## Setting Up RM Module Addresses

An apC/8X can support up to eight RMs. You can also have up to eight RM Input Modules and eight RM Output Modules.

Table 5.3 indicates how to set up addresses for the RM input/output modules. Note that each device has a unique address from 1 to 8, and that an RM's address maps to the physical number of the module.

**Table 5.3 Input/Output Addressing**

Device Type	Device Address							
	1	2	3	4	5	6	7	8
Reader	1	2	3	4	5	6	7	8
RM 8 Input	1	2	3	4	5	6	7	8
RM 8 Outputs	1	2	3	4	5	6	7	8



## CHAPTER 6



# apC/8X Panel Setup

### In This Chapter

---

- Setting Up the Main Panel 6-2
- Setting the apC/8X Jumpers 6-14

## Setting Up the Main Panel

Setting up the apC/8X main panel involves setting the panel's jumpers and DIP switches. Figure 6.1 shows these components.



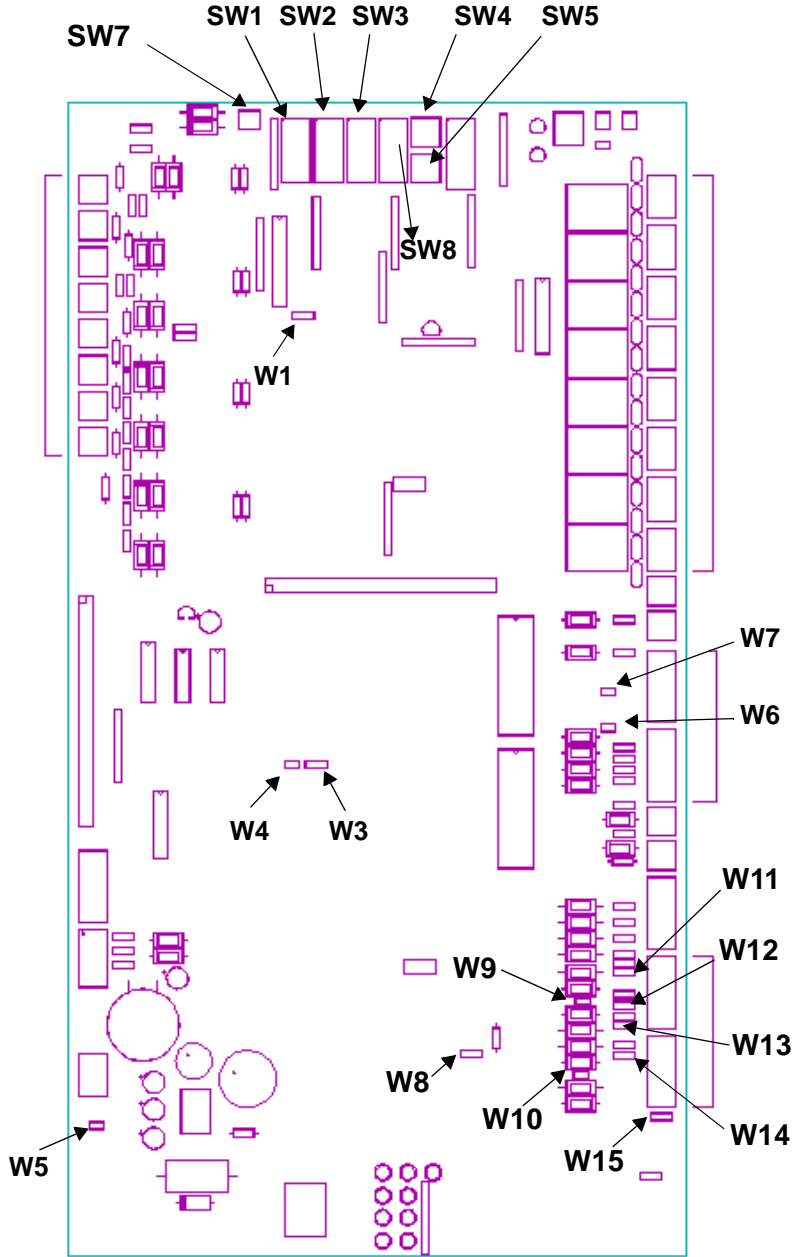


Figure 6.1 apC/8X DIP Switch and Jumper Locations

## Setting the apC/8X Switches

The top of the apC/8X has six switch packages labeled SW1 through SW5 and SW8 (see Figure 6.1).

SW1, SW2, SW3, and SW8 are DIP switch packages, each containing eight switches. This type of switch has two positions: ON (or closed) and OFF (or open). For most common installations, all switches should be in the OFF position.

SW4 and SW5 are rotary switches. To set a rotary switch, use a screwdriver to turn the arrow to the correct number.

Table 6.1 summarizes the apC/8X switch settings. Following sections describe the switch settings and their function in more detail.

**Table 6.1 apC/8X DIP Switch Settings**

Switch	Setting	* = Default	System Feature
SW1:1	ON		Database cleared on power up and/or reset
	OFF	*	Database not cleared on power up and/or reset
SW1:2	ON		No LEDs for online magnetic stripe reader
	OFF	*	Amber LED for online reader
SW1:3	ON		5-wire RS-232 format used for apC/8X
	OFF	*	Normal operation: 3-wire RS-232 or RS-485 format used for apC/8X or 4-wire connection used for dialup mode apC/8X
SW1:4	ON		Dialup mode communication is enabled
	OFF	*	Dialup mode communication is disabled
SW1:5-7	See the description later in this section	*	Set host baud rate 5,6,7 = 0 = 9600 baud

**Table 6.1 apC/8X DIP Switch Settings**

<b>Switch</b>	<b>Setting</b>	<b>* = Default</b>	<b>System Feature</b>
SW1:8	ON		Host parity none, 8 bits, 1 stop bit
	OFF	*	Host parity even, 8 bits, 1 stop bit (normal operation)
SW2:1	ON		Relay link on when door forced open
	OFF	*	No link when door forced open
SW2:2	ON		Relay link on when door held
	OFF	*	No link when door held
SW2:3	ON		Relay link on when apC/8X is offline
	OFF	*	No link when apC/8X is offline
SW2:4-5	See the description later in this section		Inputs for elevator control
SW2:6	ON		Reader keypad for PIN entry, if enabled
	OFF	*	Keypad for elevator floor selection, if enabled
SW2:7	ON		apC/8X ignores card misreads
	OFF	*	apC/8X reports misreads
SW2:8	ON		AUX port for local printout
	OFF	*	AUX port for apC/8X test program

Table 6.1 apC/8X DIP Switch Settings

Switch	Setting	* = Default	System Feature
SW3:1	ON		Card entry through keypad enabled
	OFF	*	Card entry through keypad not enabled
SW3:2	ON		Optional LED access pattern enabled at reader
	OFF	*	Normal LED access pattern enabled at reader
SW3:3	ON		Card numbers less than 65535 (16 bit)
	OFF	*	Card numbers greater than 65535 (32 bit)
SW3:4	ON		Activate/deactivate dates are stored
	OFF	*	Activate/deactivate dates are not stored
SW3:5	ON		Space reserved in card record for local anti-passback
	OFF	*	No space reserved in card record for local anti-passback
SW3:6	ON		Space reserved in card record for elevator control
	OFF	*	No space reserved in card record for local elevator control
SW3:7	ON		Magnetic stripe encryption used
	OFF	*	No Magnetic stripe encryption used
SW3:8	ON		Reverse card swipe signals duress
	OFF	*	Duress alarm disabled
SW7	Push button		Push to reset
SW8:1 through 8:8			Reserved

**SW1:1** IF SW1:1 is set to ON, the database is cleared whenever the apC/8X recovers from power loss. This switch is used only during your initial database setup. For normal operation, set the switch to OFF.

---

**Note** When you are installing a new apC/8X or an apC/8X that has been unused for a some time, power up with SW1:1 ON to clear the apC/8X memory. Then turn SW1:1 OFF.

---

**SW1:2** When SW2:1 is set to ON, an online but inactive magnetic stripe reader has no LEDs lit. Set the switch to OFF to light the amber LED for online readers to distinguish them from offline readers.

**SW1:3** Use the following table to determine the setting for this switch.

apC/8X Comm Format	Setting
RS-485	OFF
Standard, 3-wire RS232	OFF (Normal operation)
Dialup	OFF
4-wire dialup connection	OFF
5-wire RS-232 protocol	ON

**SW1:4** SW1: 4 enables apC/8X dialup communication mode. Set switch 4 to ON to operate in dialup mode. Set it to OFF to disable dialup communication. For dialup operation, switch SW1:3 must be set to OFF.

---

**Note** The system reads SW1:4 only when the apC/8X powers up with SW1:1 set to ON. Any changes you make to this switch do not take effect until the next powerup.

---

**SW1:5-7** Switches 5 through 7 set the baud rate at which the apC/8X communicates to the host computer. Set the baud rate to the highest rate

compatible with the host. If the devices are far apart or if communications errors result, lower the baud rate. All apC/8Xs in a chain must run at the same rate. If you are using a modem, set these switches to match the modem's baud rate. Baud rates and their corresponding switch settings are as follows:

Baud Rate	SW1:5	SW1:6	SW1:7
19200	ON	OFF	OFF
1200	OFF	ON	OFF
2400	ON	ON	OFF
4800	OFF	OFF	ON
9600 (default)	OFF	OFF	OFF
2400 x.25	ON	OFF	ON
4800 x.25	OFF	ON	ON
9600 x.25	ON	ON	ON

**SW1:8** Switch 8 sets the parity for communications with the computer or modem. Set it to ON for no parity; to OFF for even parity. Use even parity (OFF) with directly connected apC/8Xs. For modem communications, including apC/8X dialup mode, match the apC/8X's parity to the host's parity. With either setting, the apC/8X communicates 8-bit characters with one stop bit. Note that the apC/8X and the host will not communicate if the host, the apC/8X, and the modem parity settings are not the same.

**SW2:1** When switch SW2:1 is set to ON, the apC/8X activates Output 16 if any of the apC/8X's doors are forced open. Set the switch OFF to disable this feature.

**SW2:2** When switch SW2:2 is set to ON, the apC/8X activates Output 16 when any of the apC/8X's doors are held open past their unlock time. Set the switch to OFF to disable this feature.

**SW2:3** When switch SW2:3 is set to ON, Output 15 activates when the apC/8X goes offline from the host.

**SW2:4 and SW2:5** If SW3:6 is on, local elevator control is enabled. In this case, switches SW2:4 and SW2:5 indicate the configuration of inputs in an elevator apC/8X, as shown in the following table.

SW2:4	SW2:5	Input Configuration
OFF	OFF	No inputs used for elevator control
ON	OFF	Input 1 monitors floor selection; all other inputs used for regular input monitoring
OFF	ON	All inputs used for floor selection input
ON	ON	Reserved for system use

**SW2:6** If SW3:6 is ON, local elevator control is enabled. In this case, switch SW2:6 determines how a keypad is used in an elevator. Set the switch to ON to use the keypad for entering user PINs (if the system is configured to use PINs). Set the switch to OFF to use the keypad for floor selection.

---

**Note** The system reads SW2:4 through SW2:6 only when the apC/8X powers up with SW1:1 set to ON. Any changes you make to this switch will not take effect until the next powerup.

---

**SW2:7** Card misreads occur when the card has the wrong parity or the wrong number of bits. When switch SW2:7 is set to OFF, the apC/8X sends an access denied for misread report when it misreads a Wiegand or magnetic stripe card. When switch SW2:7 is on, the apC/8X takes no action when it misreads a card.

**SW2:8** Set switch SW2:8 to ON to print access messages and monitor point changes on a local printer connected to apC/8X diagnostic port P36. Set the switch OFF to connect to the apC/8X test program through P36.

**SW3:1** When switch SW3:1 is turned on, the apC/8X accepts card numbers entered through the keypad as well as from card swipes. Set switch SW3:1 to OFF to accept card numbers only from swipes.

**SW3:2** Set switch SW3:2 OFF to use the default access LED pattern on all readers. Set this switch to ON to cause the green LED to light solid (no flash) for an access grant or door unlock. An access deny causes the red LED to flash rapidly for two seconds.

**SW3:3, SW3:4, and SW3:5** Switches SW3:3, SW3:4, and SW3:5 affect the number of cards the apC/8X database can store.

Set switch SW3:3 on if all access cards used at the apC/8X are 16 bit cards. This includes most Wiegand, proximity, and standard magnetic stripe cards with encoded card numbers less than 65,535 (decimal). Set switch SW3:3 to OFF if you use 32 bit cards with encoded card numbers up to 999,999,999. Note that using 32 bit cards reduces the number of card records the apC/8X can store.

Switch SW3:4 allows the apC/8X to store the card activation and deactivation times. Enable this feature by setting the switch to ON.

Set switch SW3:5 to ON to enable the apC/8X to store the card location and enforce local anti-passback rules. Turn the switch off if you are not using anti-passback.

**SW3:6** The apC/8X can be used for either local or host elevator control. When switch SW3:6 is set on, the apC/8X is enabled for local elevator control. Set switch SW3:6 to OFF to disable local elevator control or to configure the apC/8X at the host for host mode elevator control. Setting this switch to OFF also allows access control at doors.

---

**Note** The system reads SW3:3 through SW3:6 only when the apC/8X powers up with SW1:1 set to ON. Any changes you make to this switch will not take effect until the next powerup.

---



**SW3:7** Setting switch SW3:7 to ON allows the apC/8X to read Software House encrypted magnetic stripe cards. Set the switch OFF if the magnetic stripe cards are not encrypted or if the apC/8X uses a different card technology.

**SW3:8** When switch SW3:8 is set to ON, a card run through a Wiegand or magnetic stripe reader in the direction opposite normal indicates a duress situation. Set switch SW3:8 OFF to disable the duress feature. The apC/8X then treats reverse card reads as the same as forward reads.

**SW4 and SW5** Use rotary switches SW4 and SW5 to indicate the apC/8X's unique two-digit address.

Table 6.2 contains the information you need to set switches SW4 and SW5. Use it to find the apC/8X's address (set at the host).

Once you find the correct address, turn SW4's arrow to the number in the corresponding row of the first column, labeled "SW4." Then, turn the arrow on SW5 to point to the number at the head of the address's column. For example, to indicate address 134, set SW4 to 8 and SW5 to 5.

---

**Note** Each apC/8X on a multidrop communications line must have a unique address.

---

**SW8:1 through SW8:8** are reserved.

**Table 6.2 SW4 and SW5 Switch Settings**

SW4	SW5															
	0	1	2	3	4	5	6	7	8	9	A	B	C	D	E	F
<b>0</b>	1	2	3	4	5	6	7	8	9	10	11	12	13	14	15	16
<b>1</b>	17	18	19	20	21	22	23	24	25	26	27	28	29	30	31	32
<b>2</b>	33	34	35	36	37	38	39	40	41	42	43	44	45	46	47	48
<b>3</b>	49	50	51	52	53	54	55	56	57	58	59	60	61	62	63	64
<b>4</b>	65	66	67	68	69	70	71	72	73	74	75	76	77	78	79	80
<b>5</b>	81	82	83	84	85	86	87	88	89	90	91	92	93	94	95	96
<b>6</b>	97	98	99	100	101	102	103	104	105	106	107	108	109	110	111	112
<b>7</b>	113	114	115	116	117	118	119	120	121	122	123	124	125	126	127	128
<b>8</b>	129	130	131	132	133	134	135	136	137	138	139	140	141	142	143	144
<b>9</b>	145	146	147	148	149	150	151	152	153	154	155	156	157	158	159	160
<b>A</b>	161	162	163	164	165	166	167	168	169	170	171	172	173	174	175	176
<b>B</b>	177	178	179	180	181	182	183	184	185	186	187	188	189	190	191	192
<b>C</b>	193	194	195	196	197	198	199	200	201	202	203	204	205	206	207	208
<b>D</b>	209	210	211	212	213	214	215	216	217	218	219	220	221	222	223	224
<b>E</b>	225	226	227	228	229	230	231	232	233	234	235	236	237	238	239	240
<b>F</b>	241	242	243	244	245	246	247	248	249	250	251	252	253	254	255	256

**W4:** Turn OFF for 128K x 8 SRAM chips; ON for 512K x 8 chips.

**W3:** Set W:3 according to the board's EPROM or FLASH type. The following table lists the settings.

W3	EPROM Type	FLASH Type
B	27C512, 27C1024	29F010, 29C010
A	4M Devices only	

**SW7** SW7, a momentary push button switch, resets the apC/8X. During the reset, the apC/8X performs a self-test and sends the test results to the control system.

## Setting the apC/8X Jumpers

Several jumpers are used on the apC/8X board. Some of these control communications features of the apC/8X. These jumpers must be set correctly for the apC/8X to function. Most of the jumpers are two-post jumpers that are either on (closed) or off (opened). Some jumpers have three posts for an A or B setting (see Figure 6.2).



**Figure 6.2 A and B Settings**

To close section A of a three-post jumper, install a jumper housing between the center post and the A post. To close section B of a three-post jumper, install a jumper housing between the center post and the B post. See Figure 6.1 for jumper locations.

Table 6.3 summarizes the apC/8X jumper settings.

**Table 6.3 apC/8X Jumper Settings**

Jumper	Setting	*= Default	System Feature
W8 and W11-15	A closed		apC/8X communicates to host through RS-485 format
	B closed	*	apC/8X communicates to host through RS-232C format
W9 and W10	CLOSED	*	apC/8X is last unit in RS-485 multidrop chain  apc/8X is directly connected to host's RS-232 COM port.
	OPEN		apc/8X is not the last unit in RS-485 multidrop chain  apc/8X uses a modem connection to host's RS-232 COM port
W5	OPEN		apC/8X's earth ground does not connect to logic ground.
	CLOSED	*	apC/8X's earth ground connects to logic ground (normal operation)
W2	OPEN	*	Normal system operation
	CLOSED		Override wall and cabinet door tamper switches
W1	A closed	*	Normal system operation
	B		DO NOT USE THIS SETTING

The following sections describe the jumpers in more detail.

**W9 and W10:** Open W9 and W10 on all but the last apC/8X in an RS-485 multidrop line. Leave the jumpers closed if the apC/8X is the last unit on the multidrop line.

These jumpers should be closed if you are using a direct RS-232C connection to the host.

**W8 and W11 - W15 (Host Port Communication Protocol)**

These jumpers determine the type of transmission at the host port. Close the A section if the apC/8X connects to the host through the RS-485 communications format. Close the B section of these jumpers if the apC/8X connects to the host through RS-232C format.

**W5** Close jumper to connect the apC/8X's earth ground to the optional logic ground.

**W2 (Cabinet Tamper Override)** Leave W2 open for normal operation. Closing W2 overrides the wall and lid tamper switches. Close the jumper for diagnostic purposes only or when using the apC/8X outside the apC/8X cabinet.

**W1** Leave in the A position for normal operation.

## apC/8X LEDs

The apC/8X has several types of LEDs:

- Communications LEDs, which indicate when data is transmitted and received from the AUX port, host computer, or reader
- LED bar, which indicates various system status
- LED on the apC/8X's cabinet door

## Communications LEDs

The communications LEDs are located at the bottom and top right half of the apC/8X (see Figure 6.3).

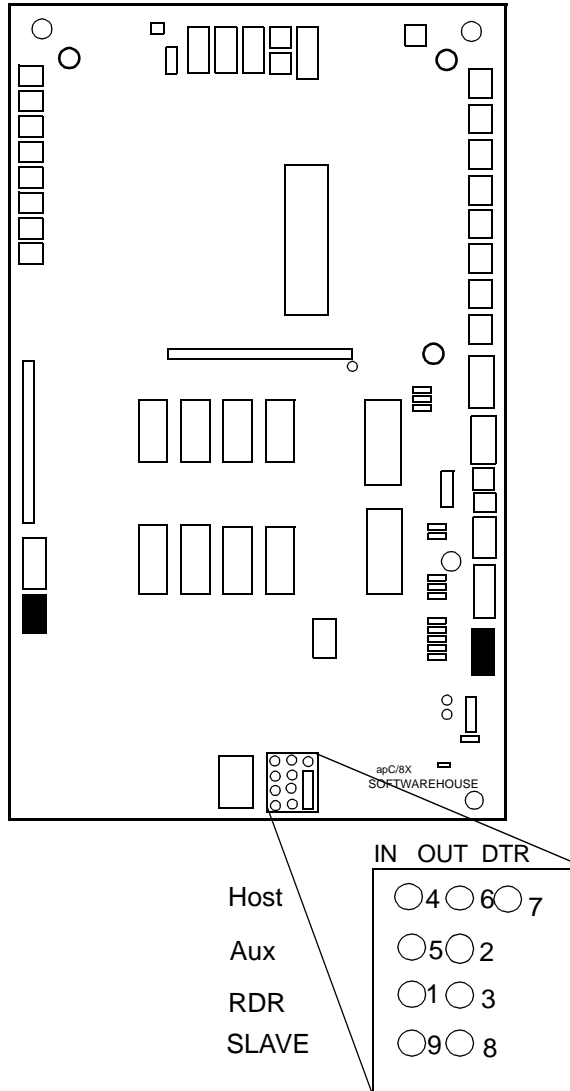


Figure 6.3 Location of apC/8X Communications LEDs



Table 6.4 lists the communications LEDs and their meaning.

**Table 6.4 apC/8X Communications LEDs**

LED	Indication
Aux port, LED 5 LED 2	Data In Data Out
Reader port, LED 1 LED 3	Data In Data Out
Host port, LED 4 LED 6 LED 7	Data In Data Out Active DTR
Slave LED 9 LED 8	Data In Data Out

## LED Bar

The LED bar is located next to the Comm LEDs.

Table 6.5 lists the color of the LEDs in the bar, their state, and their meaning.

**Table 6.5 apC/8X LED Bar**

LED	If On....	If Off...	If Flashing...
Red1	Reset/Fault	Normal operation	
Red2	Reader error; a configured reader is offline	Normal operation	
Red3	Reserved for system use	Normal operation	
Yellow1	DTR enabled but apC/L on hook with a modem that is not reporting as if it is on-line	DTR disabled	DTR on and apC/8X off the hook with modem
Yellow2	0.5 second flash when card is swiped (online reader only)	Normal operation	
Yellow3	0.5 second flash when monitor point changes (online monitor point only)	Normal operation	
Yellow4	Offline from host	Normal operation	Message received from host
Green1	0.5 second flash while scanning monitor points	Hardware problem	
Green2	1 second flash during normal operation (program heartbeat)	Hardware problem	
Green3	Power on	Power off	

---

**Note** When power is applied to the apC/8X or if the apC/8X is reset, the LED bar goes through a diagnostic self test. The LEDs should return to normal operation within 10 seconds. See Chapter 7 for further explanation.

---

## LED on the apC/8X cabinet

Three LEDs on the apC/8X cabinet door can display various states of the apC/8X (see Table 6.6).

**Table 6.6** apC/8X/L Door LED

LED	State
Power	Power is on the apC/8X
Host	apC/8Xd is on-line with the host
Fault	Reset condition which is seen at initial power up or when you push the reset switch (SW7). If the LED cycles between Fault and Host, there is a problem with the unit. (Same as Red1 on the LED bar).



## CHAPTER 7

# 7

# Testing the apC/8X Installation

This chapter describes installation test procedures for the apC/8X. Read this entire chapter before testing any apC/8X component or reader. Follow the instructions carefully.



### CAUTION

Connect all readers *before* applying power to the system. Do not connect the readers while power is applied to the system.

### In This Chapter

---

- Testing Readers 7-2
- Testing the apC/8X Main Circuit Board 7-5
- The apCTest Program 7-6

## Testing Readers

This section describes the test procedures for the Sensormatic RM readers. To test a reader for normal operation, set the reader address switch to 9, power up the reader, and follow the steps in the section appropriate for your reader. The readers can also be bench tested without being connected to an apC/8X. When you complete the test, reset the address switch to its original setting.

### Magnetic Stripe Readers

The LEDs on the reader indicate whether each step in the test procedure is successful. This section describes each step along with the LED response. If the reader has no keypad, the test procedure consists of steps 15 and 16.



#### To test the reader:

1. Press the 1 key. The red LED lights up.
2. Press the 1 key again. The red LED flashes slowly.
3. Press the 1 key again. The red LED flashes rapidly.
4. Press the 1 key again. The red LED goes out.
5. Press the 2 key. The amber LED lights up.
6. Press the 2 key again. The amber LED flashes slowly.
7. Press the 2 key again. The amber LED flashes rapidly.
8. Press the 2 key again. The amber LED goes out.
9. Press the 3 key. The green LED lights up.
10. Press the 3 key again. The green LED flashes slowly.
11. Press the 3 key again. The green LED flashes rapidly.
12. Press the 3 key again. The green LED goes out.
13. Press the 4 key. If an ARM-1 is connected, the relay should activate. Press the 4 key again to deactivate the relay.

---

**Note** Pressing the 4 key activates both relay outputs on an RM reader.

---

14. Press the 5 key to activate the card swipe test. The LEDs make no response when the key is pressed.

15. Swipe a card in the forward direction.

The green LED lights up for two seconds. If the red LED lights up, there is an error in the card read.

16. Swipe the card in the reverse direction. The amber LED lights up. If an error is read, the red LED lights up. This only applies to magnetic stripe readers.

17. Press the 6 key to test supervised input number 1. The LEDs indicate the following:

LED Response	Condition
Green LED lights	Input is in secure condition (1K)
Amber LED lights	Input is in alarm condition (500Ω)
Red LED lights	Input is in alarm condition (2K)
Amber LED flashes slowly	Input is left open (open)
Red LED flashes rapidly	Input is shorted (shorted)

**Note** Use resistors across the inputs to simulate the conditions listed in the previous table.

18. Press the 7 key to test supervised input number 2. The LED response indicates the conditions listed in the previous table.

19. Press the 8 key to test the tamper switch. If the tamper switch is depressed, the red LED is off. When the switch is released, the red LED lights up.

## RM LEDs

Each RM reader has three LEDs: red, green, and amber. The various conditions indicated by these LEDs are described in Table 7.1.

**Table 7.1 RM Reader LED Indications**

Red LED	Amber	Green	Indication
Brief flash	Brief flash	Brief flash	Power up
Off	Off	Off	Online (software flag enabled)
Off	On	Off	Online
On	Off	Off	Offline or reader tamper
Solid for 1 sec.	Off	Off	Access denied
Fast flash for 2 sec.	Off	Off	Access denied (Software Flag Enabled)
Off	Off	On	Access granted or door unlocked (Software Flag Enabled)
Off	Off	Fast flash	Access granted
Off	Off	Slow flash	Door unlocked
Off	Slow flash	Off	Enter second card (escorted access only)
Off	Fast flash	Off	Enter PIN
Off	Fast flash	Off	Enter floor # (systems configured for elevator control only)
Flash w/ each key press	Off	Flash w/ each key press	Keypad input
Slow flash	Off	Off	Reader not configured
Fast flash	Fast flash	Fast flash	Alarm: door forced/held open
On	On	On	Error condition: Remove power to prevent damage to RM



## Non-Sensormatic Readers

Swipe a card in the forward direction. The red LED on the reader lights up. If you have questions regarding testing non-Sensormatic readers, contact Sensormatic customer support for assistance.

# Testing the apC/8X Main Circuit Board

The apC/8X should be disconnected from the host when you test it. The LEDs on the apC/8X main circuit board indicate whether the board is functioning properly.



### To test the main circuit board:

1. Remove power from the apC/8X and disconnect the reader wiring.
2. Apply power to the apC/8X.
3. About one second after turning on power, the top RED LED on the LED BAR turns ON for approximately one-half second.
4. RED1 goes OFF, and the other nine LEDs turn ON.
5. After a delay of approximately 5 seconds, the LED BAR cycles from RED2 through YELLOW2. If larger memory options are installed, the other LEDs turn on, indicating a memory test.
6. GREEN3 remains ON, GREEN2 flashes every second, GREEN1 flashes every 1/2 second, and YELLOW4 remains ON.
7. Reader Data LED1 at the bottom of main board should flash rapidly about every three seconds. This indicates that the apC/8X is attempting to poll a reader.

If the test procedure does not complete all of the preceding steps, contact Sensormatic customer support.

## The apCTest Program

The apCTest program lets you perform a full test of the apC/8X and the readers to which it is connected. You can test an apC/8X either as a stand-alone device or as a device that is on-line with the host. The program is supplied as one file on a 720K 3.5" disk. Contact Sensormatic customer support for further information.

## APPENDIX A



# Equipment Specifications

### In This Appendix

---

- Operating Environment A-2
- Equipment Dimensions and Weights A-3
- RM Series Card Reader Configurations A-5

## Operating Environment

- Power consumption: Less than 10 watts typical
- Temperature range: 32° F to 158° F (0° C to 70° C)
- Temperature range with optional battery backup: 32° F to 122° F (0° C to 50° C)

## Equipment Dimensions and Weights

Unit	Height	Depth	Width	Weight
ARM-1	1.7 in. (43 cm)	0.53 in. (1.3 cm)	0.75 in. (1.91 cm)	1 oz. (0.03 kg)
apC/8X w/ cabinet	24 in. (61 cm)	4 in. (10.2 cm)	16.55 in. (42.3 cm)	19 lb w/o power supply (8.6 kg) 20 lb w/ power supply (9 kg)
apC/8X circuit board	16.01 in. (40.7 cm)	0.6 in. (1.5 cm)	8.6 in. (21.8 cm)	1 lb. 2 oz. (0.51 kg)
apC I/32	7.6 in. (19.3 cm)	0.7 in. (1.8 cm)	9.7 in. (24.9 cm)	13 oz. (0.37 kg)
apC R/48	15.5 in. (39.37 cm)	0.75 in. (1.9 cm)	8.1 in. (20.57 cm)	27 oz. (0.76 kg)
Standard star coupler	16 in. (40.6 cm)	0.6 in. (1.5 cm)	3.0 in. (7.65 cm)	10 oz. (0.28 kg)
Wiegand/proximity star coupler, upper board	9.6 in. (24.5 cm)	0.6 in. (1.5 cm)	3.0 in. (7.65 cm)	7 oz. (0.21 kg)
Wiegand/proximity star coupler, lower board	16 in. (40.6 cm)	0.86 in. (2.18 cm)	3.0 in. (7.65 cm)	10 oz. (0.28 kg)
Magnetic stripe reader (RM-1, RM-2)	5.10 in. (12.95 cm)	1.95 in. (4.95 cm)	5.6 in. (14.22 cm)	21 oz. (588 g)
Mullion reader (RM-3)	5.10 in. (12.95 cm)	1.81 in. (4.6 cm)	1.91 in. (4.85 cm)	10 oz. (280 g)
Wiegand swipe reader	2.3 in. (5.8 cm)	1.7 in. (4.3 cm)	5.3 in. (13.5 cm)	12.5 oz. (0.38 kg)
Wiegand insertion reader	1.8 in. (4.4 cm)	3.5 in. (8.9 cm)	4.5 in. (11.4 cm)	15 oz. (0.42 kg)

Unit	Height	Depth	Width	Weight
Wiegand key reader	1.1 in. (2.9 cm)	2.0 in. (5.1 cm)	1.4 in. (3.6 cm)	5.8 oz (0.13 kg)

# RM Series Card Reader Configurations

The following three tables list the RM series card reader configuration by model number. A check in a column indicates the feature is available on that model.

**Table A.1 RM Series Magnetic Stripe Readers**

Model	Standard	Rugged	Keypad	LCD	Mullion
RM1-MP <sup>1</sup>	✓				
RM2-MP <sup>1</sup>	✓		✓		
RM2L-MP <sup>1</sup>	✓		✓	✓	
RM3-MP <sup>1</sup>	✓				✓

**Table A.2 RM Series Proximity Readers**

Model	Indala	Hughes	Keypad	LCD	Mullion
RM1-PI	✓				
RM1-PH		✓			
RM2-PI	✓		✓		
RM2L-PI	✓		✓	✓	
RM2-PH		✓	✓		
RM2L-PH		✓	✓	✓	
RM3-PH		✓			✓

**Legend** 1 = Maximum card thickness is 0.033

2 = Maximum card thickness is 0.059

**Table A.3 RM Series Wiegand Readers**

Model	Keypad	LCD	Mullion
RM1-W			
RM2-W	✓		
RM2L-W	✓	✓	
RM3-W			✓

## Environmental Specifications

Table A.4 lists the optimal operating conditions for the RM series readers.

**Table A.4 RM Series Readers Environmental Specifications**

Model	Operating Temperature (Environmental)	Operating Temperature with Heater Kit	Power Requirements	Dimensions
Magnetic Stripe: RM1-MP, RM1-MP/C, RM2-MP, RM2-MP/C	32° F to 140° F 0° C to 60° C	-22° F to 140° F -30° C to 60° C	+12V DC 80 mA	5.10 x 5.60 x 1.95 in. 12.95 x 14.22 x 4.95 cm 21 oz. (588 g)
Magnetic Stripe with LCD Display: RM2L-MP	32° F to 140° F 0° C to 60° C 95% humidity Non-condensing	Not applicable	+12V DC 180 mA	5.10 x 5.60 x 1.95 in. 12.95 x 14.22 x 4.95 cm 23 oz. (644g)
Magnetic Stripe Mullion: RM3-MP, RM3-MP/C	32° F to 140° F 0° C to 60° C	-22° F to 140° F -30° C to 60° C	+12V DC 80 mA	5.10 x 1.91 x 1.81 in. 12.95 x 4.85 x 4.60 cm 10 oz. (280g)



Table A.4 RM Series Readers Environmental Specifications

Model	Operating Temperature (Environmental)	Operating Temperature with Heater Kit	Power Requirements	Dimensions
Indala Proximity RM1-PI, RM1-PI/C, RM2-PI/C	32° F to 140° F 0° C to 60° C	-22° F to 140° F -30° C to 60° C	+12V DC 80 mA	5.10 x 5.60 x 1.95 in. 12.95 x 14.22 x 4.95 cm 25 oz. (700 g)
Indala Proximity with LCD display: RM2L-PI	32° F to 140° F 0° C to 60° C 95 humidity Non-condensing	Not applicable	+12V DC 180 mA	5.10 x 5.60 x 1.95 in. 12.95 x 14.22 x 4.95 cm 27 oz. (756 g)
Hughes Proximity: RM1-PH, RM1-PH/C, RM2-PH, RM2-PH/C	32° F to 140° F 0° C to 60° C	-22° F to 140° F -30° C to 60° C	+12V DC 135 mA average 250 mA peak	5.10 x 5.60 x 1.95 in. 12.95 x 14.22 x 4.95 cm 21 oz. (588 g)
Hughes Proximity with LCD Display: RM2L-PH	32° F to 140° F 0° C to 60° C 95 humidity Non-condensing	Not applicable	+12V DC 235 mA average 350 mA peak	5.10 x 5.60 x 1.95 in. 12.95 x 14.22 x 4.95 cm 23 oz. (644 g)
Hughes Promity Mullion: RM3-PH, RM3-PH/C	-22° F to 149° F -30° C to 65° C	Not applicable	+12V DC 135 mA average 250 mA peak	5.10 x 1.91 x 1.81 in. 12.95 x 14.22 x 4.60 cm 10 oz. (280 g)
Wiegand: RM1-W, RM1-W/C, RM2-W, RM2-W/C	32° F to 140° F 0° C to 60° C	-32° F to 140° F 0° C to 60° C	+12V DC 80 mA	5.10 x 5.60 x 1.95 in. 12.95 x 14.22 x 4.95 cm 25 oz. (700 g)
Wiegand with LCD Display RM2L-W	32° F to 140° F 0° C to 60° C 95% humidity Non-condensing	Not applicable	+12V DC 180 mA	5.10 x 5.60 x 1.95 in. 12.95 x 14.22 x 4.95 cm 25 oz. (700 g)
Wiegand with Mullion: RM3-W	-40° F to 158° F -40° C to 70° C	Not applicable	+12V DC 80 mA	5.10 x 1.91 x 1.81 in. 12.95 x 14.22 x 4.60 cm 13 oz. (364 g)

The RM-4 personality board has the following environmental specifications.

<b>Operating Temperature (Environmental)</b>	<b>Operating Temperature with Heater Kit</b>	<b>Power Requirements</b>	<b>Dimensions</b>
32° F to 140° F 0° C to 60° C	32° F to 140° F 0° C to 60° C	+12V DC 75 mA	4.65 x 3.55 x 0.60 in. 11.81 x 9.02 x 1.52 cm 9 oz. (252 g)

## A P P E N D I X    B

# B

# Calculating Maximum Wiring Lengths

### In This Appendix

---

- Using the Worksheet B-3

The RM-4 requires at least 7.5 volts to operate properly. While the apC/8X supplies 12 volts at its connectors, the amount of power that actually reaches each personality board in a chain is less than 12 volts. The voltage is lowered by each reader and by the resistance of the wire. Whether a personality board chain needs a local power supply depends on **all** of the following factors:

- Number of readers in the chain
- Distance between the first RM-4 board and the apC/8X
- Distance between the readers in the chain
- Wire gauge used to connect the readers and the apC/8X

Use the worksheet in this appendix to calculate the power in a chain. Be sure you read and understand the instructions and the examples in each

section before you begin to calculate the maximum wiring lengths for your application.

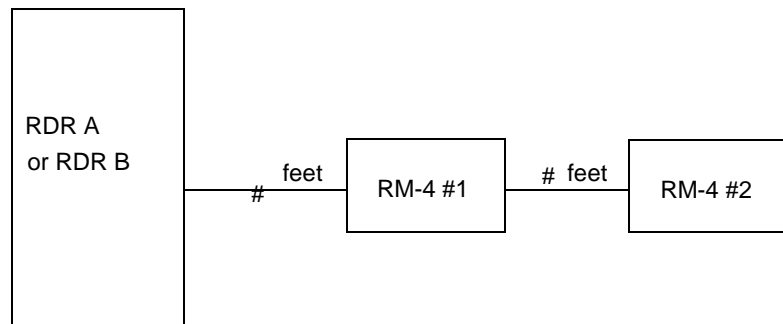
## Using the Worksheet

Use this worksheet to determine whether the readers in your layout fall within the allowable wiring length range. To use the worksheet, you need to know the type of wire used to connect the RMs to the apC/8X and the distances between each element of the chain.



### To determine wiring length range:

1. Fill in the blanks in the figure with the wiring distances between the apC/8X and the first reader and between each of the following readers. If you estimate the distances, be sure to overestimate, rather than underestimate. Use only the spaces corresponding to the RMs you have. For example, if you are using RMs and only 4, use only spaces 4, 3, 2, and 1.



2. In the following table, find the wire resistance (ohms per foot) for the type of wire you are using.

Wire Type	Resistance (ohms per foot)
18 AWG	0.01277
22 AWG	0.03227

3. Write the resistance value from step 2 in each box of the Wire resistance per foot column in the wire length worksheet.
4. On the worksheet, find the intersection of the Wire length (ft) column and the row corresponding to the total number of RMs in the chain. In that box, enter the distance between the apC/8X and the first reader. Check the diagram in step one for the distances.

5. In each of the boxes in the wire length column below the box used in step 4, enter the wire lengths between the readers in the chain. Use only the rows corresponding to your number of readers. You will not use all rows unless you have two readers.
6. Multiply the figures across in each row. Enter the result in each box of the Total power drop column.
7. Add the Total voltage drop column. The total cannot exceed 4.5 volts. If your total is greater than 4.5 volts, you must do one of the following to insure proper operation of the RM module:

Shorten the wire lengths  
 Use a heavier wire  
 Use a local power supply

**Table B.1 Wiring Length Worksheet**

RM #	Current drawn by module	Wire resistance per foot	Wire length from apC/8X or previous reader	Total voltage drop for this reader
8	X 0.2	X _____	X _____ =	_____
7	X 0.2	X _____	X _____ =	_____
6	X 0.2	X _____	X _____ =	_____
5	X 0.2	X _____	X _____ =	_____
4	X 0.2	X _____	X _____ =	_____
3	X 0.2	X _____	X _____ =	_____
2	X 0.2	X _____	X _____ =	_____
1	X 0.2	X _____	X _____ =	_____

Total Voltage drop for the chain of readers:

## Sample Calculation Using the Worksheet

This example shows you how to use the worksheet to make sure that your RMs have adequate power.

Suppose your installation uses 18 AWG wire to connect three RMS to the apC/8X.

The RMs are laid out as follows.

- The first RM is 50 ft. from the apC/8X
- The second RM is 500 ft. from the first
- The third RM is 250 ft. from the second

---

**Note** This is the same layout described in the previous example using the wiring length tables.

---



### To perform this sample calculation:

1. Enter the wiring lengths in the blanks in the worksheet. Note that not all spaces will be filled in.
2. The wire resistance per foot for 18 AWG wire is 0.01277 ohm per foot.

The completed worksheet should look like this.

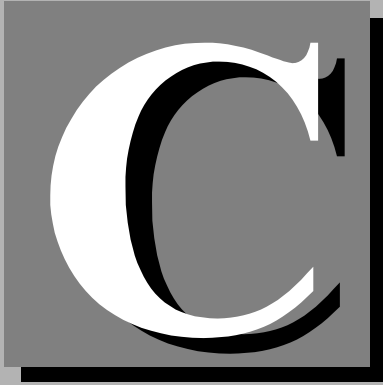
**Table B.2 Sample Completed Worksheet**

RM#	Current drawn by Module	Wire resistance per foot	Wire length from apC/ 8X or previous reader (ft)	Total voltage drop of this reader
8	X_____ 0.2	X 0.01277	X_____ =	
7	X_____ 0.2	X 0.01277	X_____ =	
6	X_____ 0.2	X 0.01277	X_____ =	
5	X_____ 0.2	X 0.01277	X_____ =	
4	X_____ 0.2	X 0.01277	X_____ =	
3	X_____ 0.2	X 0.01277	X 50 =	0.3831
2	X_____ 0.2	X 0.01277	X 500 =	2.554
1	X_____ 0.2	X 0.01277	X 250 =	0.6385
Total Voltage drop for the chain of readers:				3.5756

- The total voltage drop for this chain is 3.5756 volts. Since this is less than the 4.5 volts maximum, the wiring is adequate for this installation.



## A P P E N D I X C



# Packing and Shipping the apC/8X

This appendix contains instructions for packing an apC/8X unit and shipping it in for repair. Before shipping the unit, call the Sensormatic (Software House) Material Support Center to get a Return Authorization Number.

---

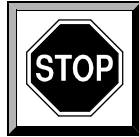
**Note** You must get a Return Authorization Number from the Material Support Center before returning an apC/8X unit. Parcels that are not marked with a Return Authorization Number will be refused at the factory and returned to you C.O.D.

---

When you call the Material Support Center, please have available:

- A complete description of your reason for returning the equipment
- The apC/8X unit's serial number and part number. This is located on the inside door template.
- A purchase order number to cover any non-warranty repairs even if the unit is under warranty

Always ship the apC/8X unit in the specially designed box and unique packing material in which you received it.



## CAUTION

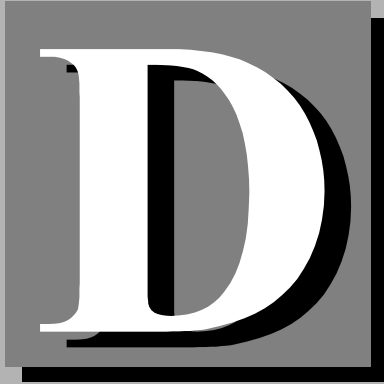
The printed circuit boards inside the apC/8X unit can be damaged by static electricity. When handling boards:

- Make sure your work area is static safeguarded.

Transport all apC/8X components in static shield containers.

Pack the unit carefully to avoid damage in transit, and make sure each package is marked with the Return Authorization Number that the Material Support Center assigned to you. Reference this number in all further communications about the returned equipment.

## A P P E N D I X   D



# Modem Settings

This Appendix contains the information you need to set up the Sensormatic OEM modems for use with the apC/8X panel.

### In This Appendix

---

- Dialup Modem Settings   D-1
- Configuring Modems for Use with Dialup Line Configuration   D-3
- Configuring Modems for Use with Leased Line Configuration   D-4
- OEM HyperTerminal Edits for 4-Wire Leased Lines   D-7
- Panel to Modem Connection Diagram   D-9
- OEM to Host Computer Cable Connection   D-9
- Configuring Modems with Software   D-9

## Dialup Modem Settings

An apC/8X in dialup mode connects to a remote host system using standard, voice-grade telephone lines instead of hardwired or leased

telephone lines. In many applications, dialup mode is more convenient and cheaper than other communications modes.

Sensormatic Access Control Division has identified a special OEM modem for dialup and lease-line applications. This modem has been manufactured to Sensormatic ACD specifications to guarantee optimal performance when used with the C•CURE 750, C•CURE 800, and C•CURE 1 Plus Ultra in either dialup or lease-line configurations.

Sensormatic ACD has tested both Hayes and US Robotics modems in the past and has found that due to constantly changing manufacturer's specifications, we could not guarantee that the next release of a particular modem would still function properly with previously defined setups and your system requirements. Sensormatic ACD does not guarantee operation nor offer technical support for any modem other than our OEM modem.

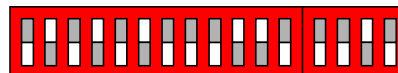
You can configure modems by using software commands or by setting DIP switches. The DIP switch settings are shown on tables D1 through D3 on page D-3, page D-5 and page D-6 of this appendix.

## Configuring Modems for Use with Dialup Line Configuration

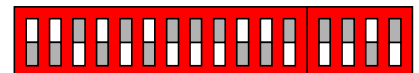
**Table D.1 OEM Modem Switch Settings for Dialup**

Switch	Host	apC
#1	DOWN	UP
#2	UP	UP
#3	DOWN	DOWN
#4	UP	UP
#5	DOWN	DOWN
#6	UP	UP
#7	DOWN	DOWN
#8	DOWN	DOWN
#9	DOWN	DOWN
#10	UP	UP
#11	UP	UP
#12	DOWN	DOWN
#13	DOWN	DOWN
#14	DOWN	DOWN
#15	UP	UP
#16	DOWN	DOWN

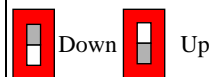
HOST



APC



KEY



## Configuring Modems for Use with Leased Line Configuration

You must set your panel using direct connect settings rather than the dial up settings for leased line. Also if you are using leased lines, it is very important that you understand the decibel (dB) loss specifications of the leased line to be used. Software House, Sensormatic ACD supports 0 or -10 dB loss with the MT1932BL modem and -9 or -15 dB loss with the MT2834BL modem. This is controlled on the OEM modem by switch 3.

The dB Transmission rate is the strength of the signal being delivered by the telephone company. A 0-dB Transmission rate is the strongest signal possible. After that the -# dB's are used to weaken the strength of the signal. The telephone company sets most leased lines to a 0-dB loss. The only time you would need to set a -# dB loss is if you were located near the telephone company and needed to weaken the signal because of the close proximity to the source of the signal. In most cases a 0-dB level is the desired setting. Be sure you verify this information with the telephone company prior to ordering the OEM modem to ensure you have to proper model mode for the dB transmission level of your lease line.

### **MT2834BL Series:**

DIP-Switch #3 adjusts dB transmission levels required by some phone carriers. Place DIP-Switch #3 in the DOWN position to enable -9 dB transmission. Place DIP-Switch #3 in the UP position to enable -15 dB transmission.

-9dB Transmission = Switch #3 DOWN

-15dB Transmission = Switch #3 UP

Factory Default Setting = DOWN

### **MT1932BL Series:**

DIP-Switch #3 adjusts dB transmission levels required by some phone carriers. Place DIP-Switch #3 in the DOWN position to enable 0 dB transmission. Place DIP-Switch #3 in the UP position to enable -10 dB transmission.

0dB Transmission = Switch #3 DOWN

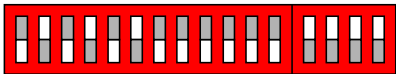
-10dB Transmission = Switch #3 UP

Factory Default Setting = DOWN

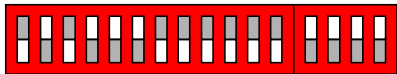
**Table D.2 OEM Modem Switch Settings for 2-Wire Leased Lines**

Switch	Host	apC
#1	DOWN	DOWN
#2	UP	UP
#3	DOWN	DOWN
#4	UP	UP
#5	DOWN	UP
#6	UP	UP
#7	DOWN	DOWN
#8	DOWN	DOWN
#9	DOWN	DOWN
#10	DOWN	DOWN
#11	DOWN	DOWN
#12	DOWN	DOWN
#13	UP	UP
#14	UP	UP
#15	UP	UP
#16	UP	UP

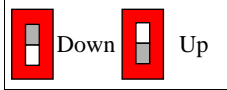
HOST



APC

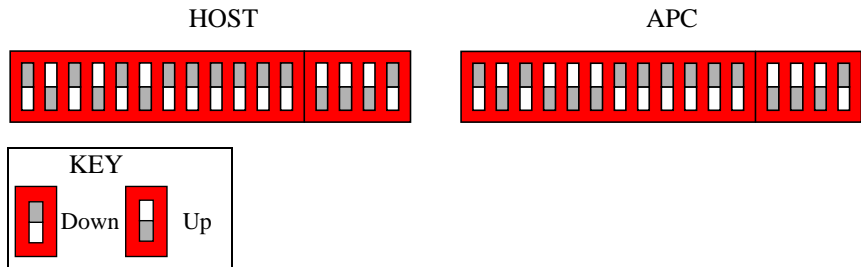


KEY



**Table D.3 OEM Modem Switch Settings for 4-Wire Leased Lines**

Switch	Host	apC
#1	DOWN	DOWN
#2	UP	UP
#3	DOWN	DOWN
#4	UP	UP
#5	DOWN	UP
#6	UP	UP
#7	DOWN	DOWN
#8	DOWN	DOWN
#9	DOWN	DOWN
#10	DOWN	DOWN
#11	DOWN	DOWN
#12	DOWN	DOWN
#13	UP	UP
#14	UP	UP
#15	UP	UP
#16	DOWN	DOWN





## OEM HyperTerminal Edits for 4-Wire Leased Lines

From a HyperTerminal Session you will type the following commands:

---

**Note** You must switch the Dip Switch #10 to the UP position in order for your HyperTerminal session to work properly. Ensure that after these changes are made that you place Dip Switch #10 back to the DOWN position. It is normal to not see the commands as you type them. The only response you will see in your session is after you press <ENTER> following the list s-register command)

---

**ATL6** <ENTER> (Lists the S-Registers)

```
S0 S2 S3 S4 S5 S6 S7 S8 S9 S10 S11 S13 S18 S19 S24 S25 S30
000 043 013 010 008 004 055 004 006 007 080 037 030 001 020 000 000
```

**ATS18=0** <ENTER> (Sets the ATS18 Register to 000)

**ATS19=0** <ENTER> (Sets the ATS19 Register to 000)

**AT&W** <ENTER> (Stores the changes you just made to the Registers)

**ATL6** <ENTER> (Verify your 18 and 19 Registers are now "000")

```
S0 S2 S3 S4 S5 S6 S7 S8 S9 S10 S11 S13 S18 S19 S24 S25 S30
000 043 013 010 008 004 055 004 006 007 080 037 000 000 020 000 000
```

**Table D.4 Host Computer Settings**

Your communications port should have the following settings:

Baud Rate	9600
Bits	8
Parity	None
Stop Bit	1
Flow Control	None

\*\*Do not add/configure the modem on the Windows control panel. Use the control panel to set only the port settings.\*\*

## Panel to Modem Connection Diagram

Figure D.1 below shows the interconnection details for connecting a modem to an APC/8X panel.

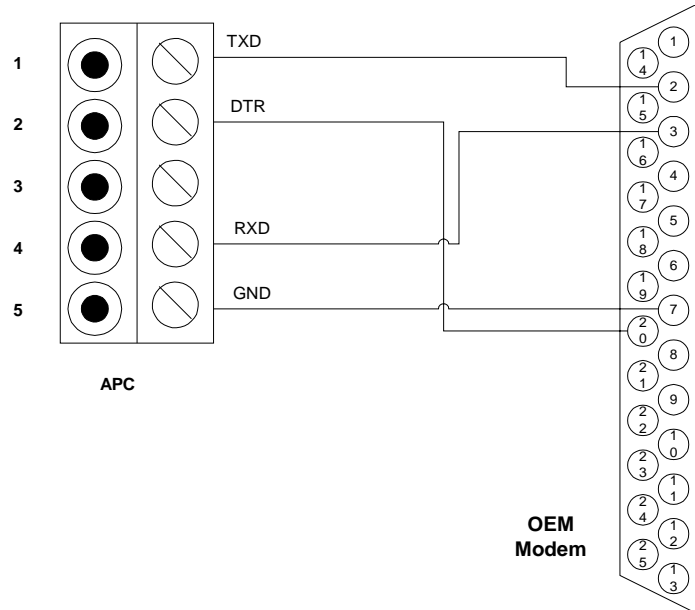


Figure D.1 apC - OEM Modem Wire Diagram

## OEM to Host Computer Cable Connection

Use an “off the shelf” straight-through modem cable (DB9 - DB25 or DB25 - DB25).

# Configuring Modems with Software

The apC/8X automatically sets up modems that are configured using software commands, based on the modem’s default settings. However, the default settings of some modems do not turn command echo off and enable DTR. This causes unpredictable behavior when the apC/8X is used in dialup mode.

To ensure proper operation with modems normally configured with software commands, you must preprogram the modems manually at a terminal with the following pre-programming commands.

---

AT&F <CR>	Recall factory defaults
ATE0 <CR>	Command echo off
AT&D2 <CR>	Enable DTR
AT&W <CR>	Save as the first user-defined configuration

---

---

**Note** If your modem does not accept these commands, consult the modem documentation for the equivalent commands.

---

Perform this procedure only once after installation, since user-defined configuration will be restored with each power-up. Consult your modem documentation for more information about configuring your particular modem.

## A P P E N D I X E



# Templates and Technical Drawings

This appendix contains the following templates:

Figure E.1 apC/8X Template

Figure E.2 apC I/32 Supervised Input Module

Figure E.3 apC/R48 Relay Module

Figure E.4 apC Star Coupler

Figure E.5 Wiegand/Proximity Star Coupler (Upper Board)

Figure E.6 Wiegand/Proximity Star Coupler (Lower Board)

Figure E.7 Input Bus Module

Figure E.8 Output Bus Module

Figure E.9 apC/8X Housing

Figure E.10 apS Housing

Figure E.11 apC to RM Wiring Using IFS Fiber Optics

Figure E.12 IFS Network Star to apC Wiring

Figure E.13 apC to Host Wiring using IFS Fiber Optics

Figure E.14 Wiegand/Proximity Wiring to the RM-4

Figure E.15 Keypad Connections (RM-4)

Figure E.16 Wiegand/Proximity Star Coupler Reader Port Connections

Figure E.17 Wiegand/Proximity Star Coupler Hughes/IDI & Sensor

Figure E.18 Indala Two Wire LED Control Wiring

Figure E.19 Indala Single Wire LED Control Wiring

Figure E.20 Heater Kit Wiring



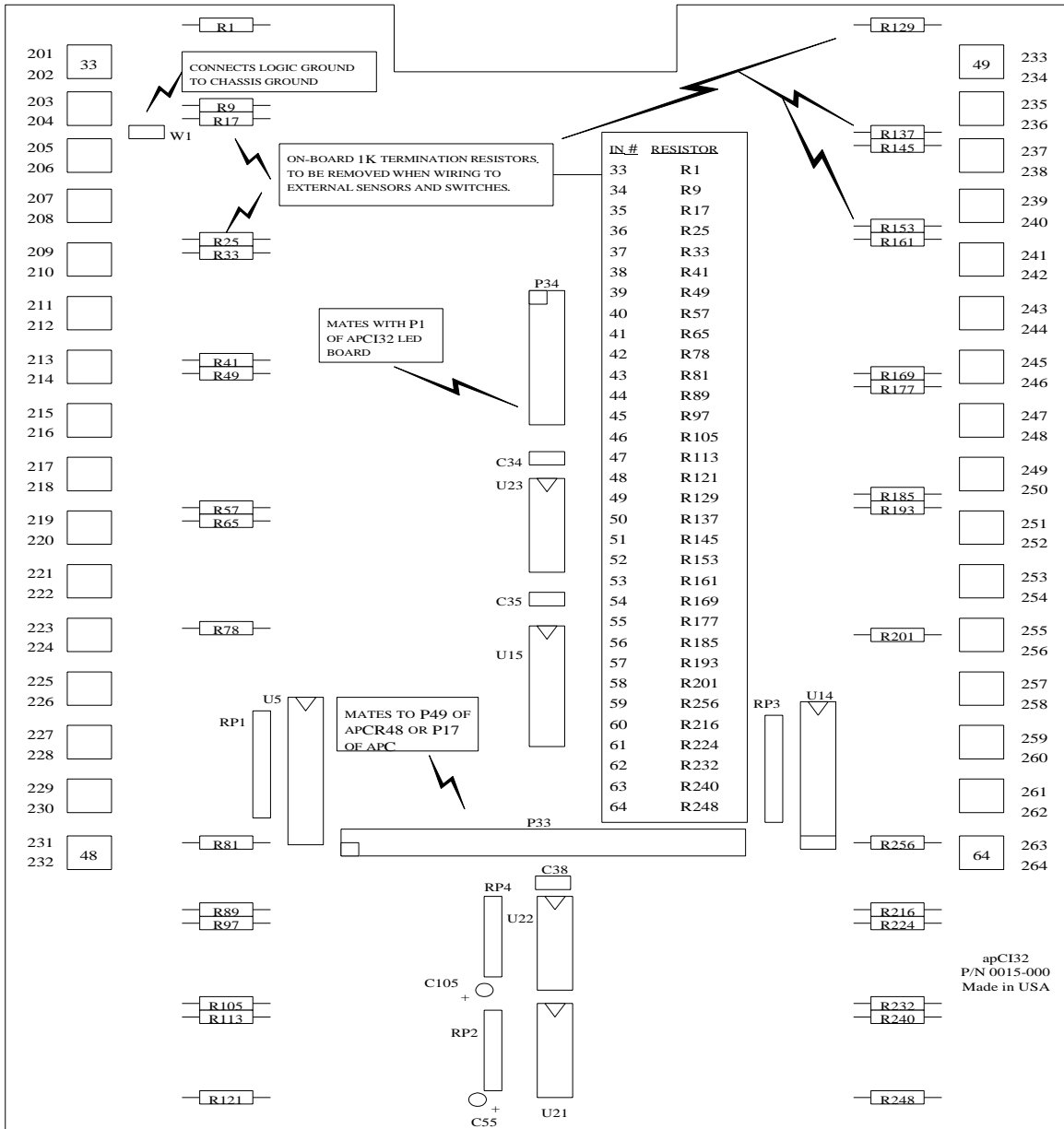


Figure E.2 apC I/32 Supervised Input Module



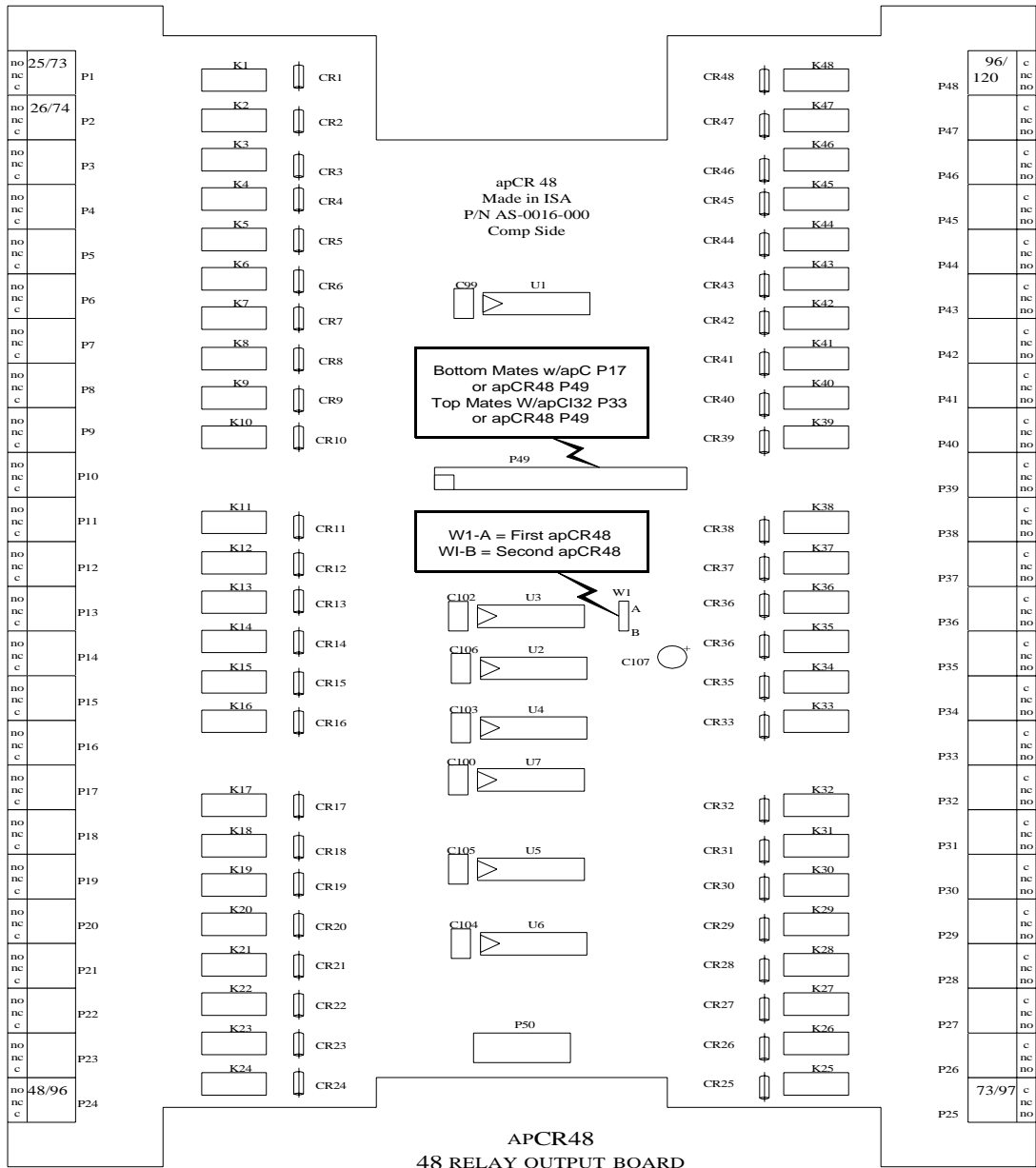


Figure E.3 apC R/48 Relay Module

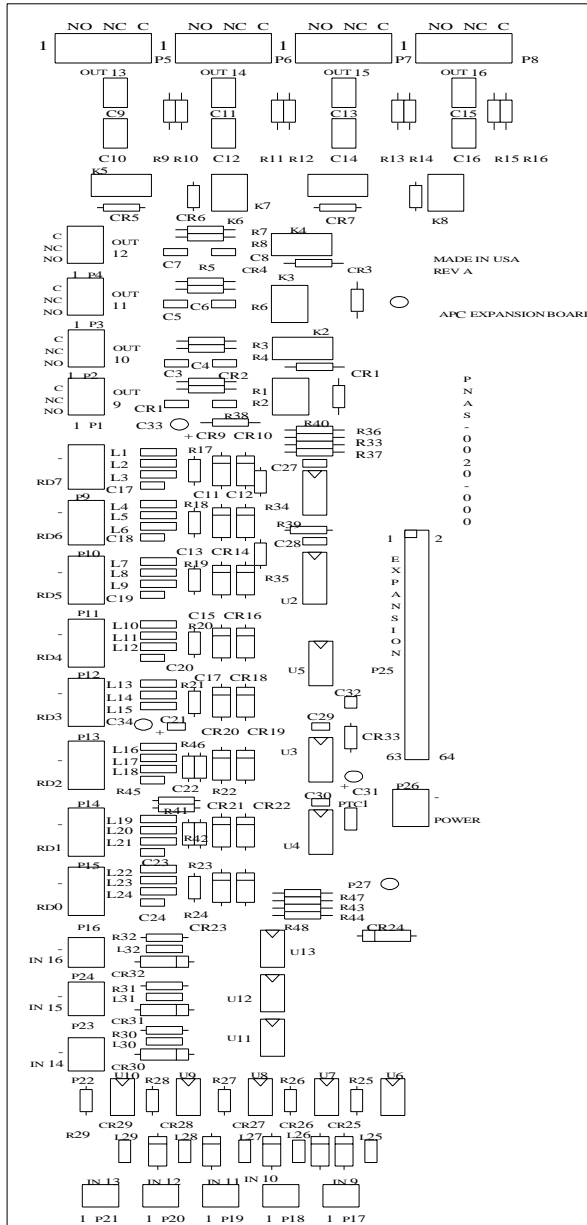
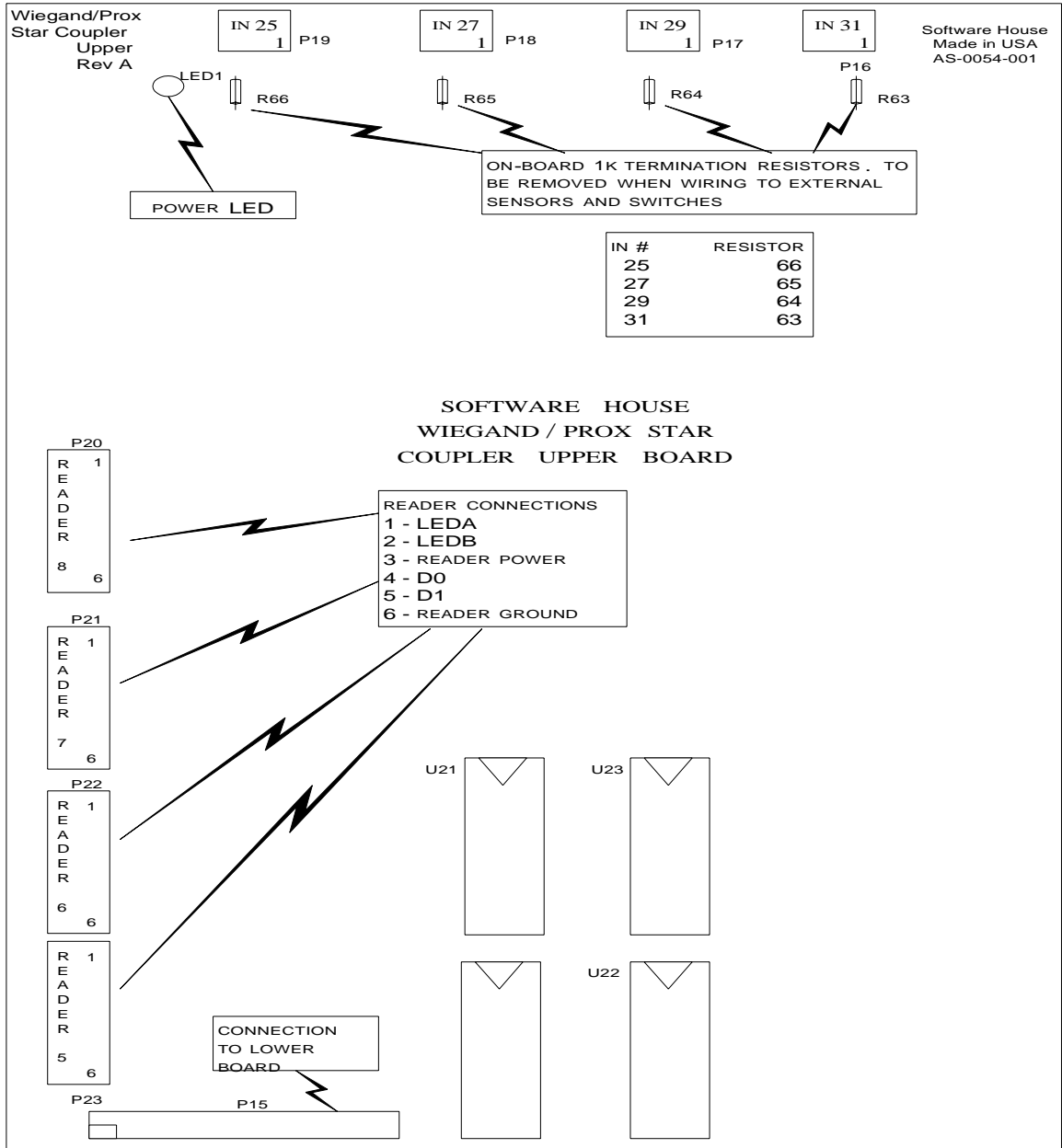


Figure E.4 apC Star Coupler



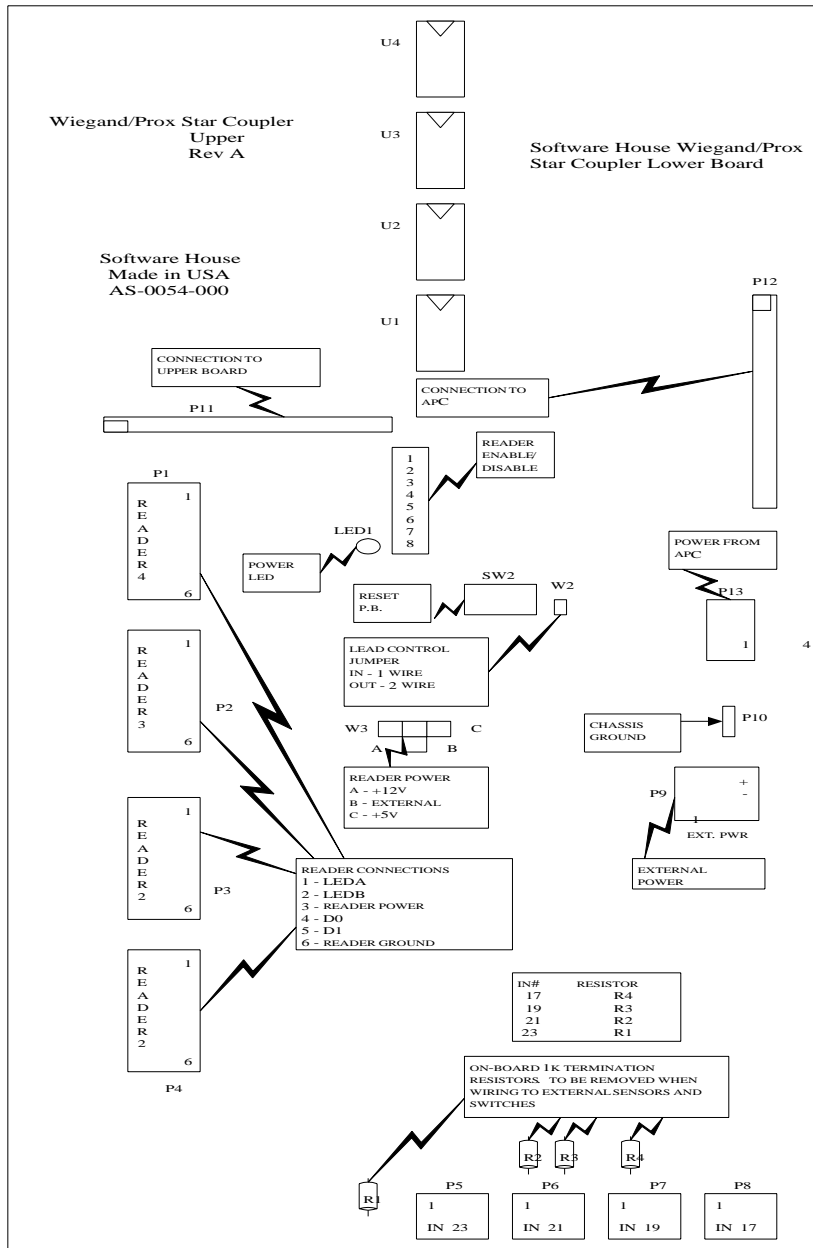


Figure E.6 Wiegand/Proximity Star Coupler (Lower Board)

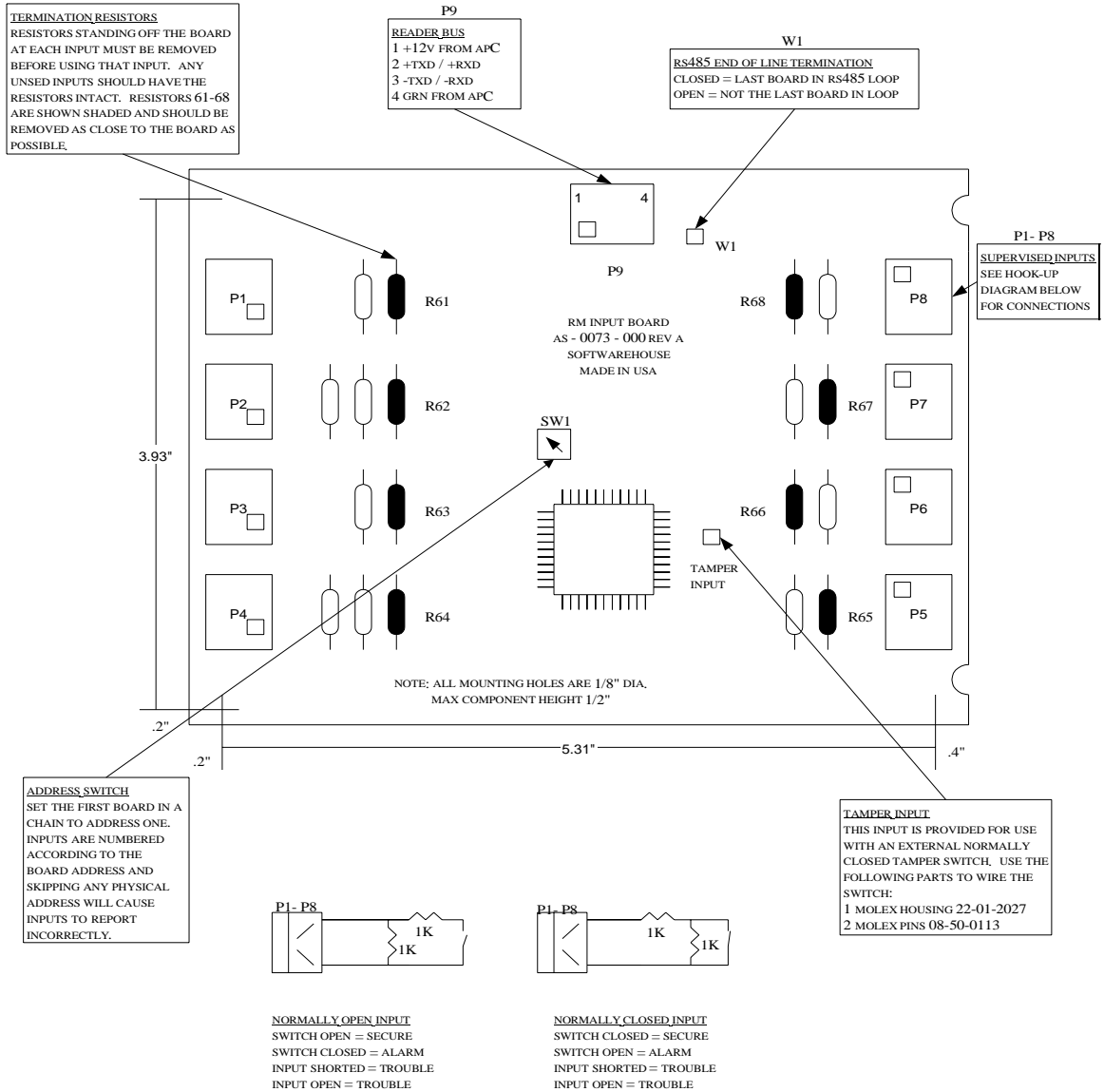
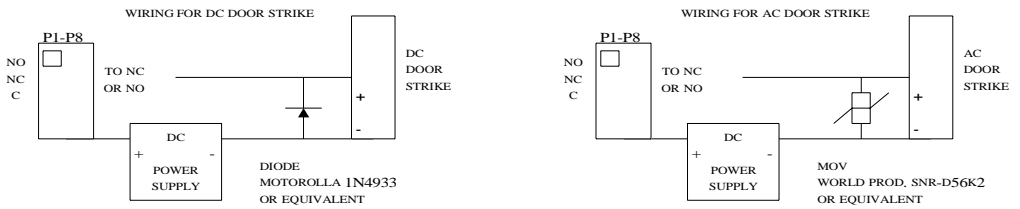
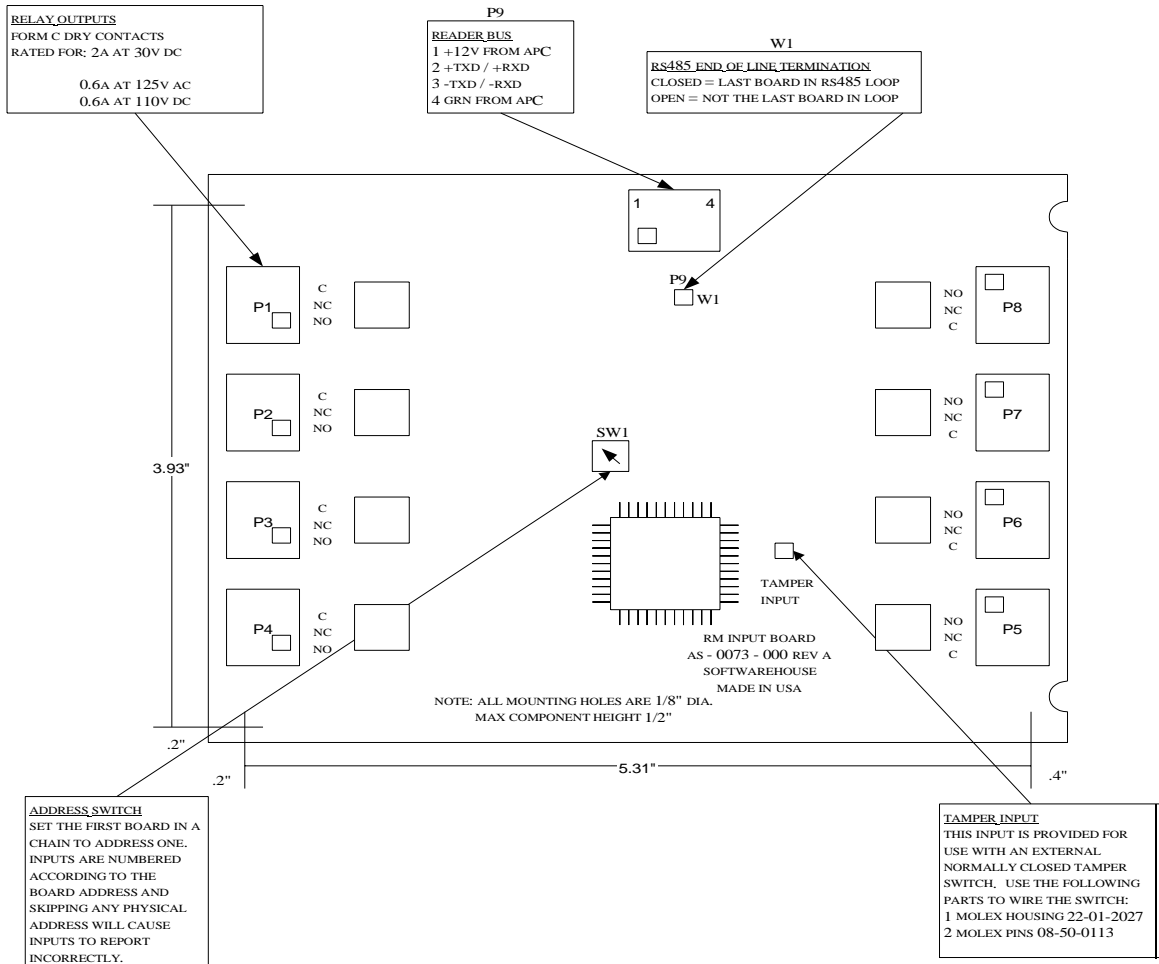


Figure E.7 Input Bus Module



NOTE: LOCATE DIODE OR MOV AS CLOSE TO STRIKE AS POSSIBLE

Figure E.8 Output Bus Module

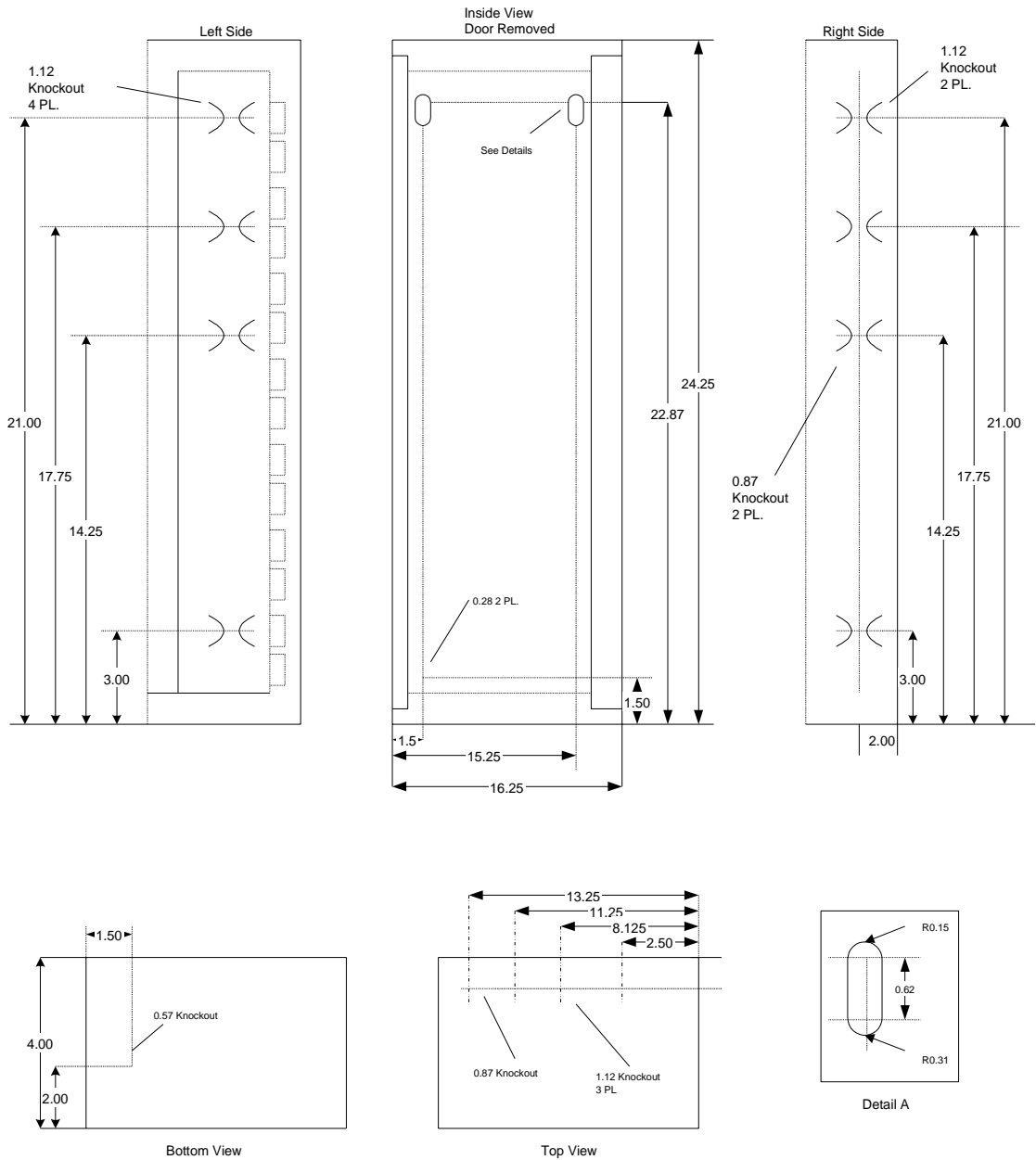


Figure E.9 apC/8X Housing

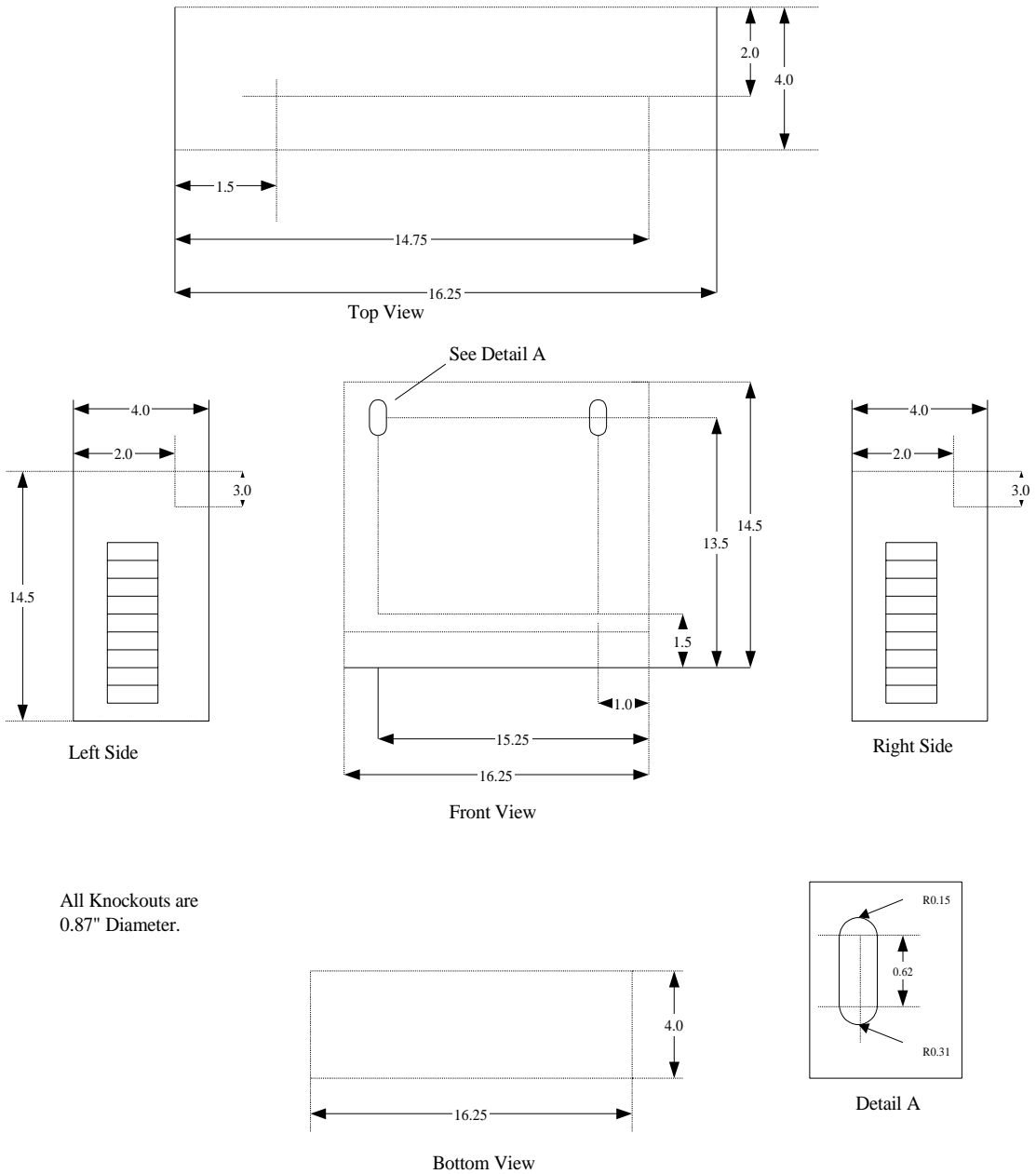
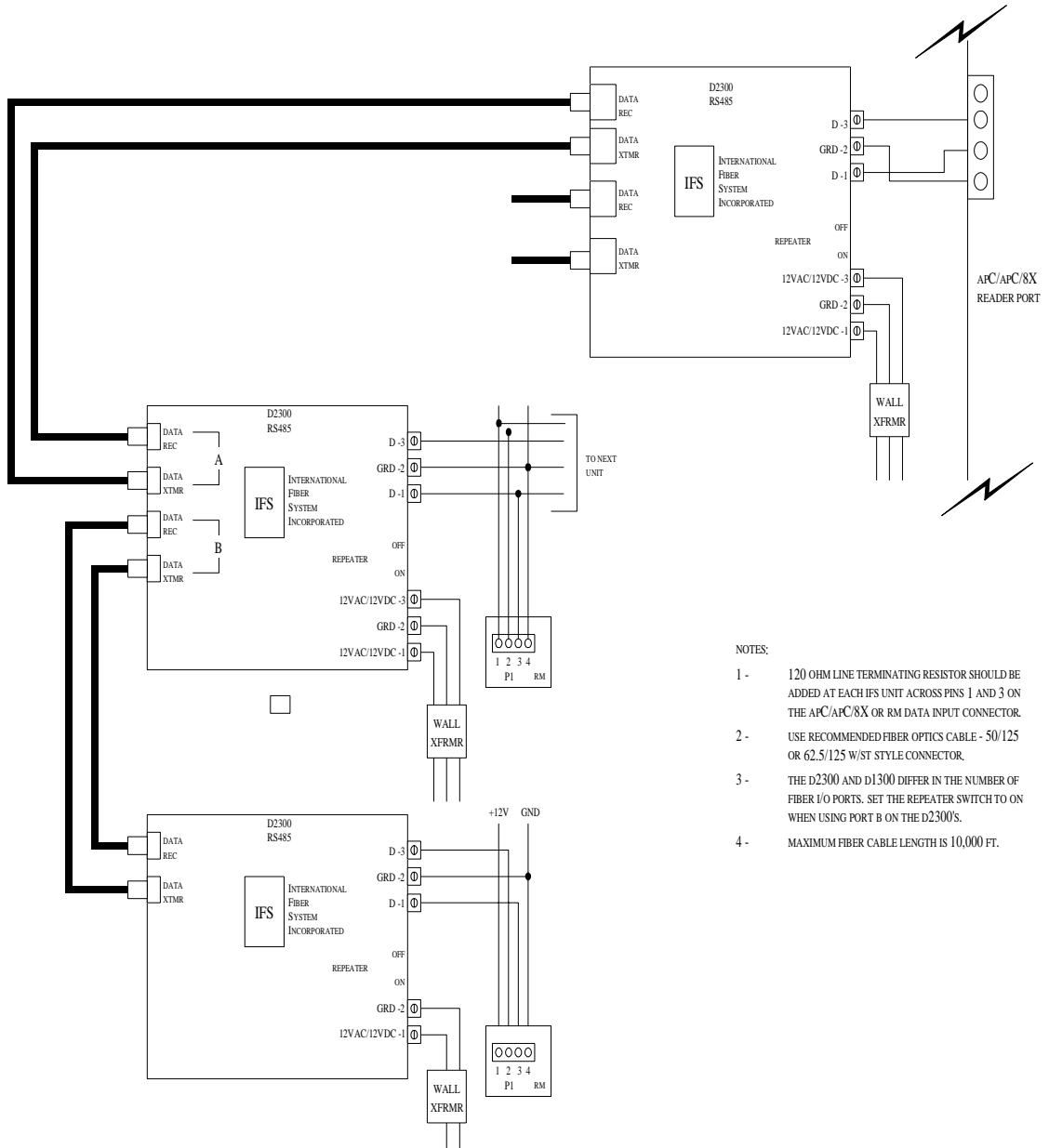


Figure E.10apS Housing





NOTES:

- 1 - 120 OHM LINE TERMINATING RESISTOR SHOULD BE ADDED AT EACH IFS UNIT ACROSS PINS 1 AND 3 ON THE APC/APC/8X OR RM DATA INPUT CONNECTOR.
- 2 - USE RECOMMENDED FIBER OPTICS CABLE - 50/125 OR 62.5/125 W/ST STYLE CONNECTOR.
- 3 - THE D2300 AND D1300 DIFFER IN THE NUMBER OF FIBER I/O PORTS. SET THE REPEATER SWITCH TO ON WHEN USING PORT B ON THE D2300'S.
- 4 - MAXIMUM FIBER CABLE LENGTH IS 10,000 FT.

Figure E.11 apC to RM Wiring Using IFS Fiber Optics

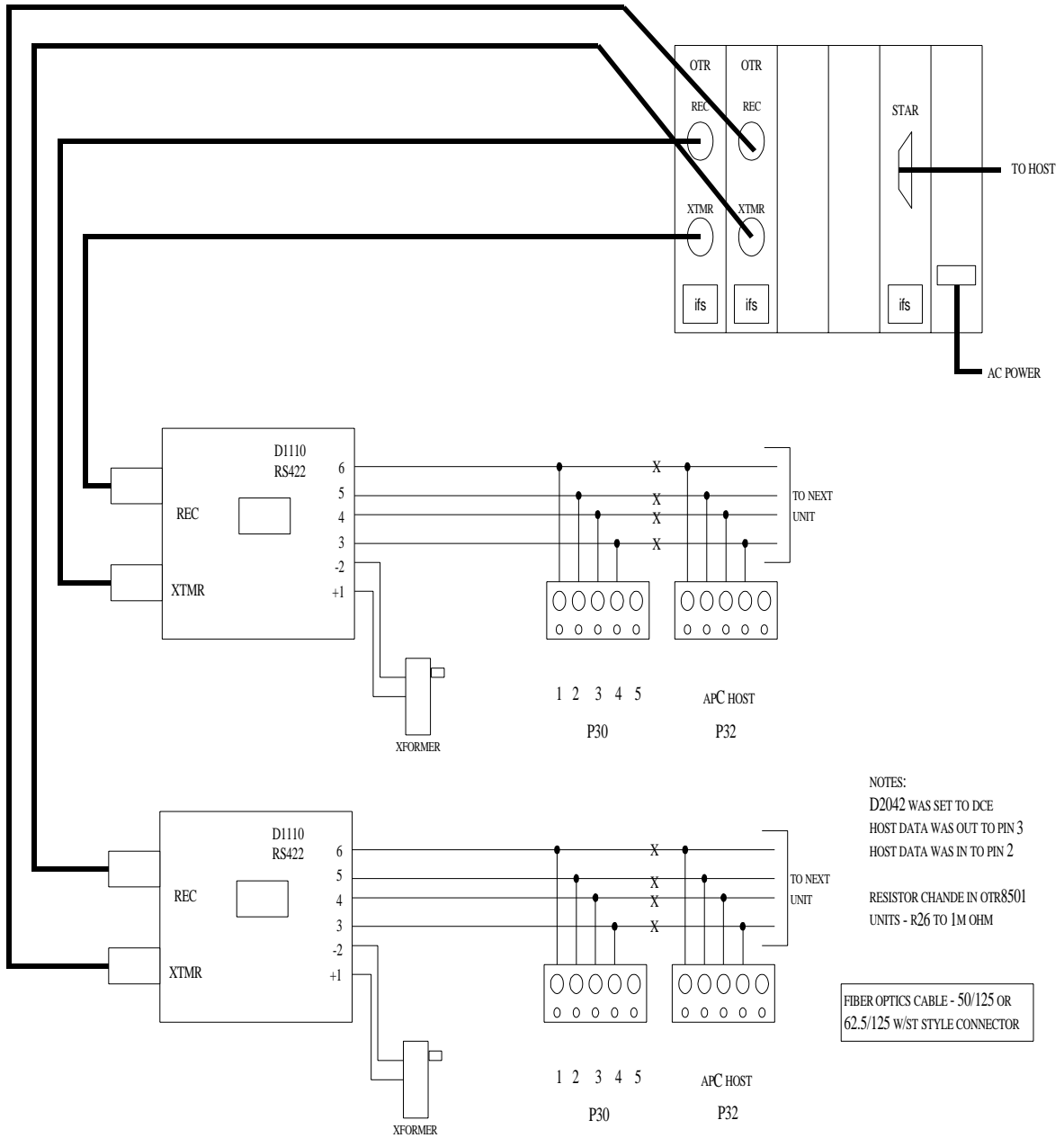


Figure E.12 IFS Network Star to apC Wiring

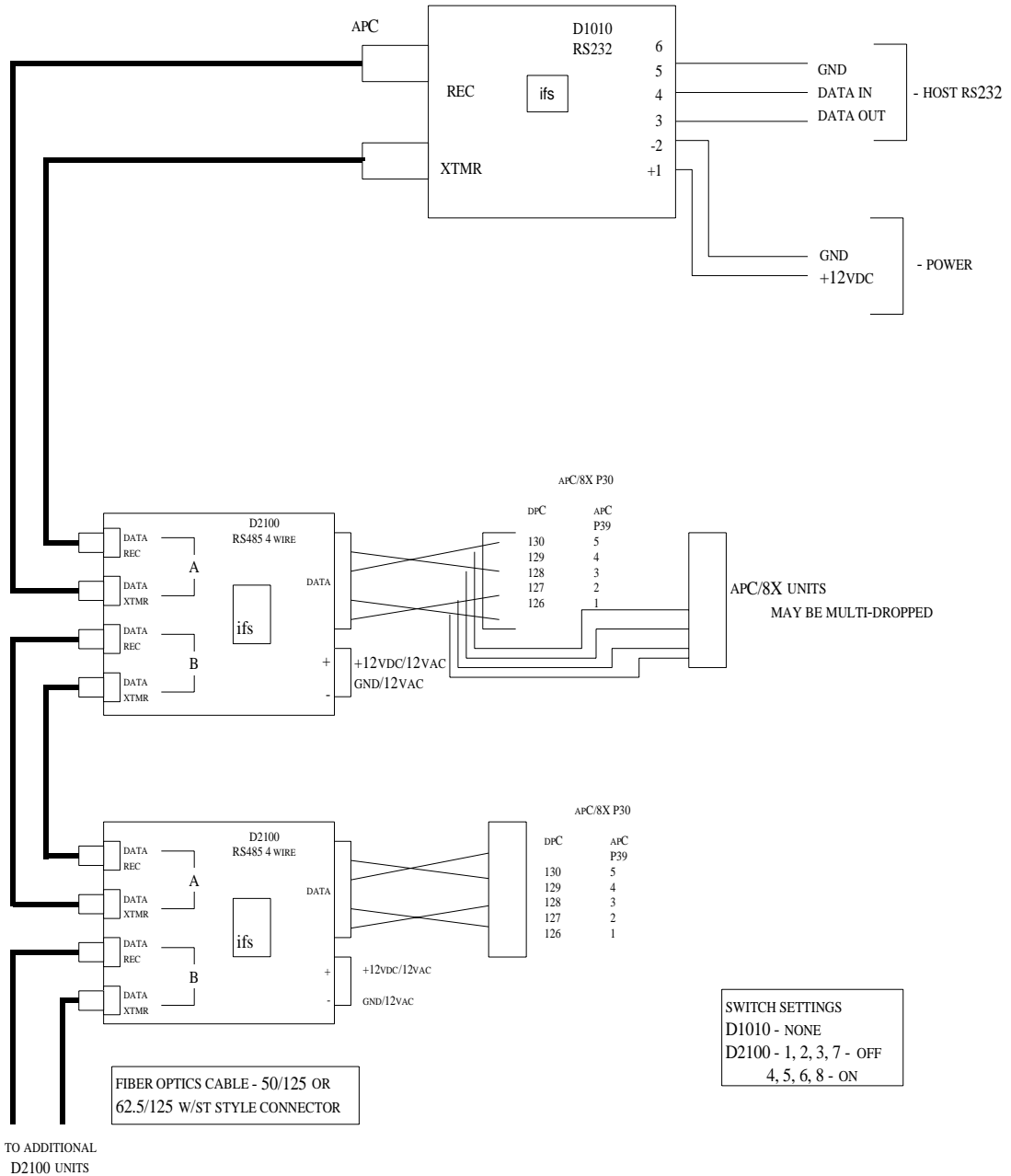
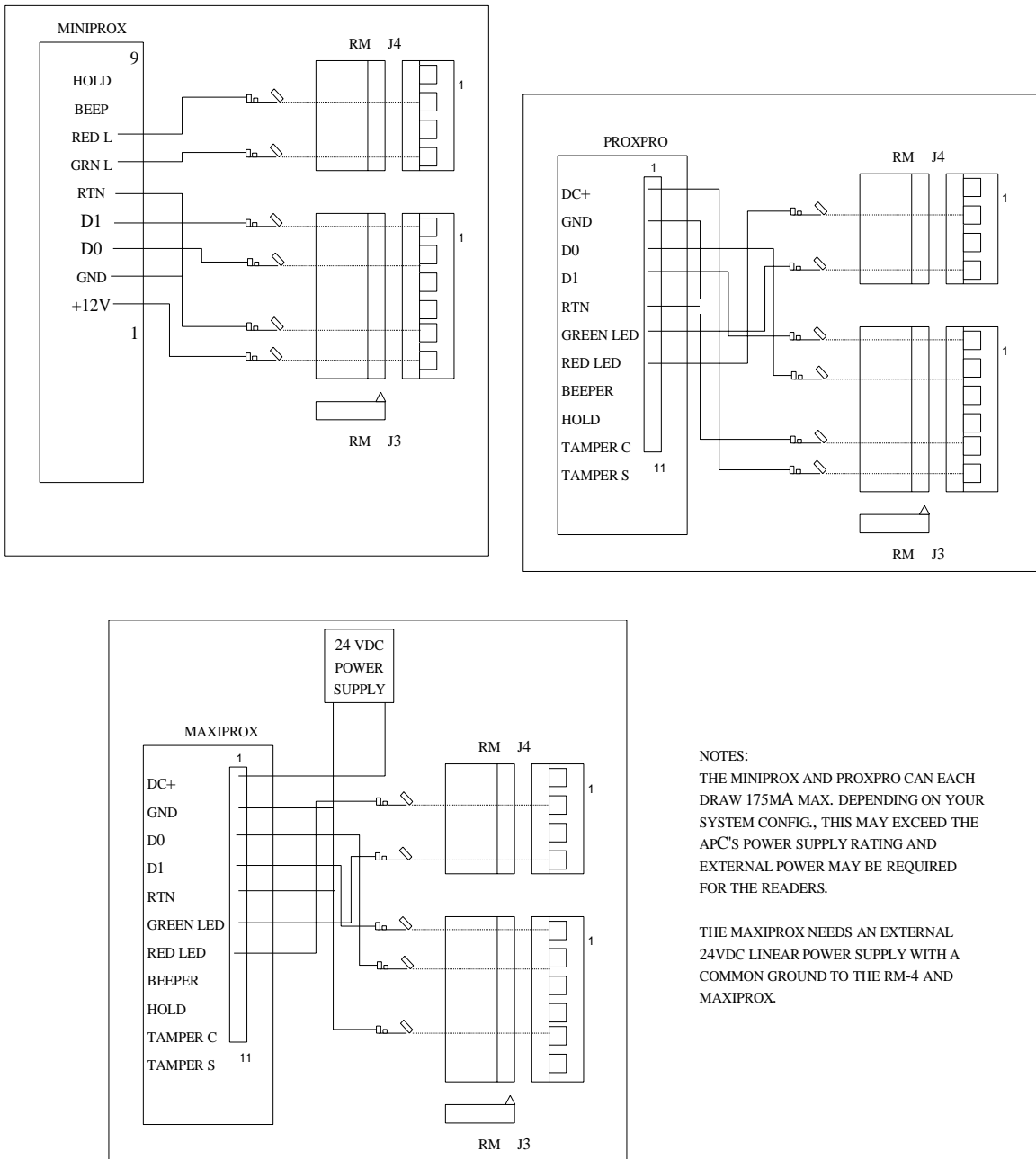


Figure E.13 apC to Host Wiring using IFS Fiber Optics

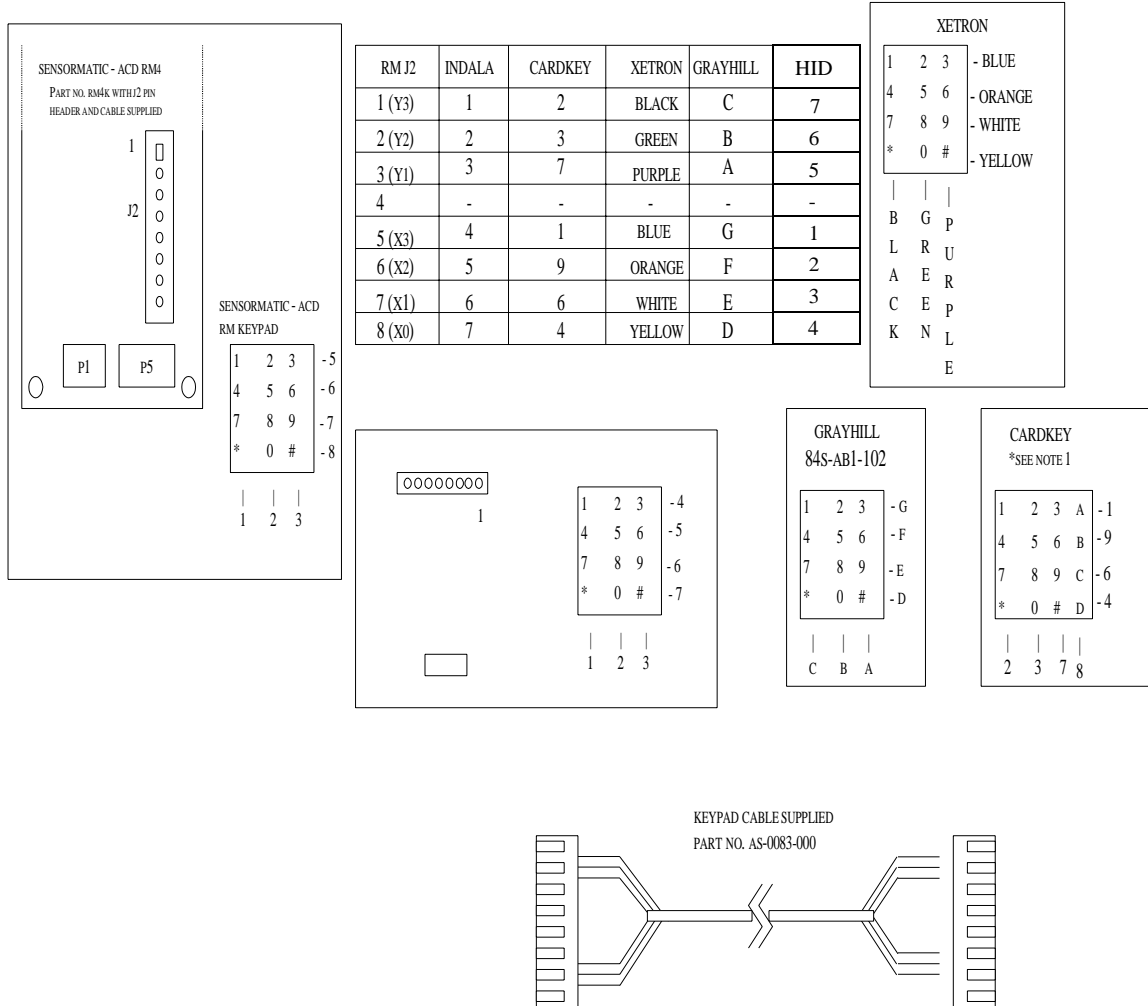


NOTES:  
 THE MINIPROX AND PROXPRO CAN EACH DRAW 175mA MAX. DEPENDING ON YOUR SYSTEM CONFIG, THIS MAY EXCEED THE APC'S POWER SUPPLY RATING AND EXTERNAL POWER MAY BE REQUIRED FOR THE READERS.

THE MAXIPROX NEEDS AN EXTERNAL 24VDC LINEAR POWER SUPPLY WITH A COMMON GROUND TO THE RM-4 AND MAXIPROX.

Figure E.14 Wiegand/Proximity Wiring to the RM-4

RM 4 KEYPAD CONNECTIONS



- NOTES:
- 1 - THE FOURTH COLUMN OF A 4X4 KEYPAD IS NOT SUPPORTED BY THE RM 4.
  - 2 - DO NOT ATTEMPT TO MODIFY OR LENGTHEN THE CABLE.
  - 3 - USE THE CHART TO DETERMINE PIN PLACEMENT AT THE KEYPAD.

Figure E.15 Keypad Connections (RM-4)

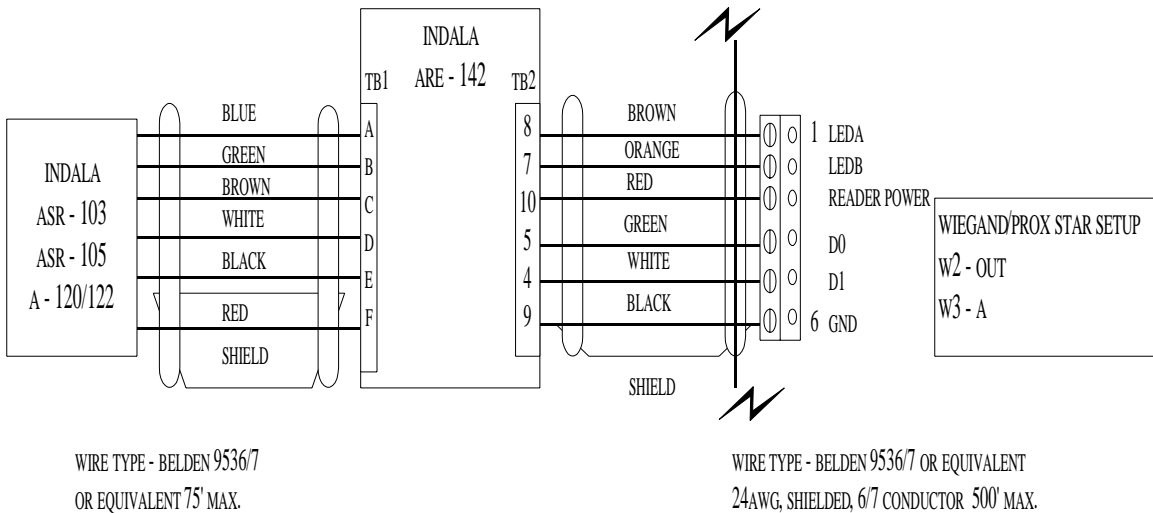
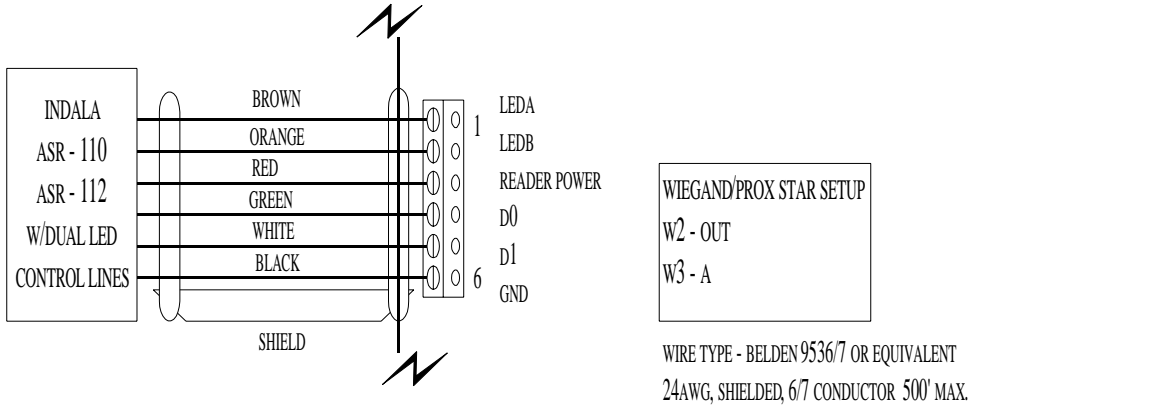


Figure E.16 Wiegand/Proximity Star Coupler Reader Port Connections

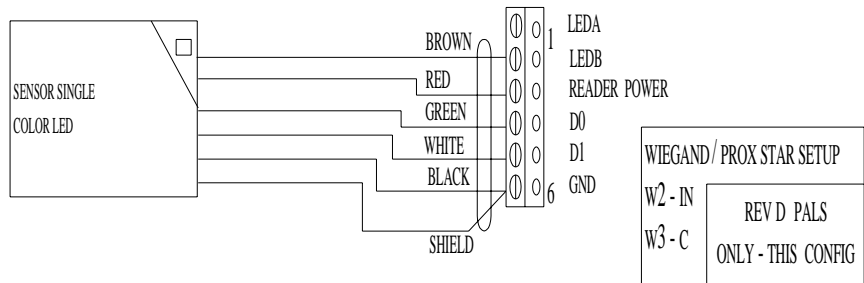
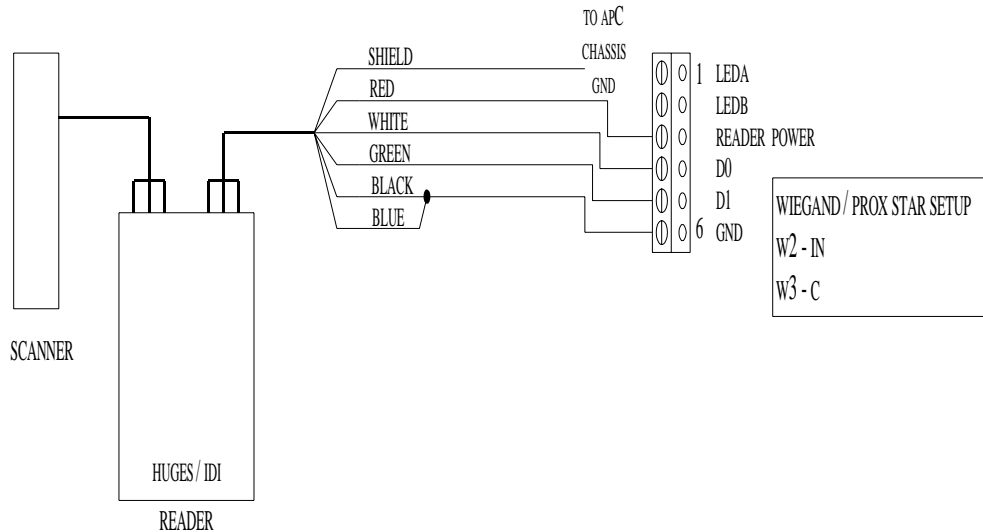
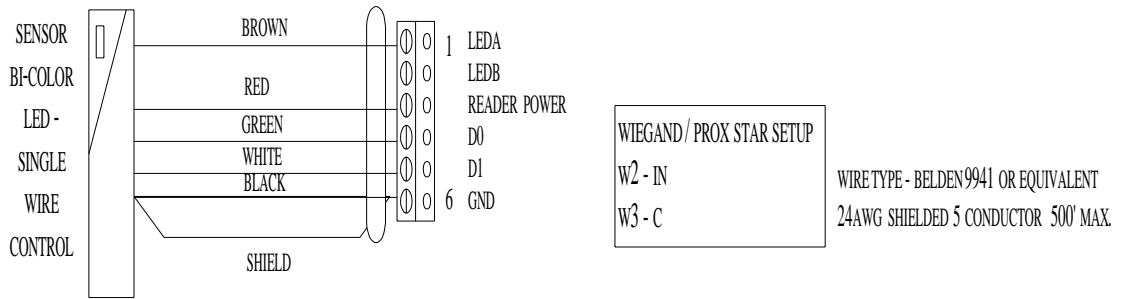
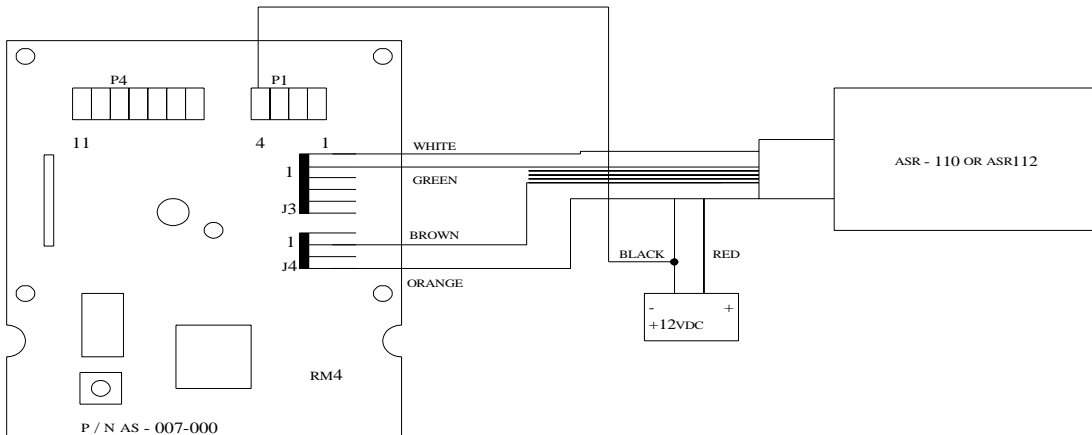
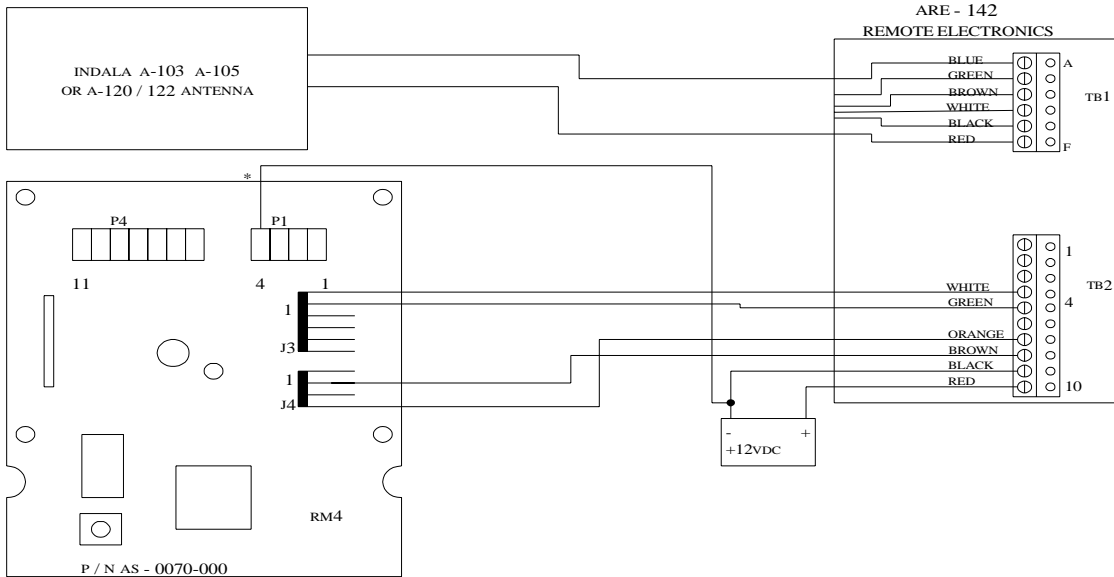


Figure E.17 Wiegand/Proximity Star Coupler Hughes/IDI & Sensor

INDALA ADVANTAGESERIES BI-COLOR LED READER TO RM WIRING  
FOR DUAL WIRE LED CONTROL

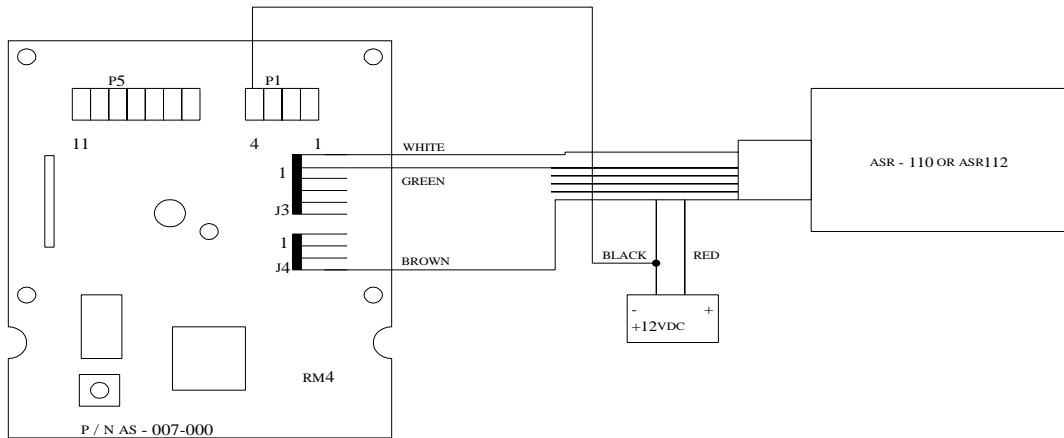
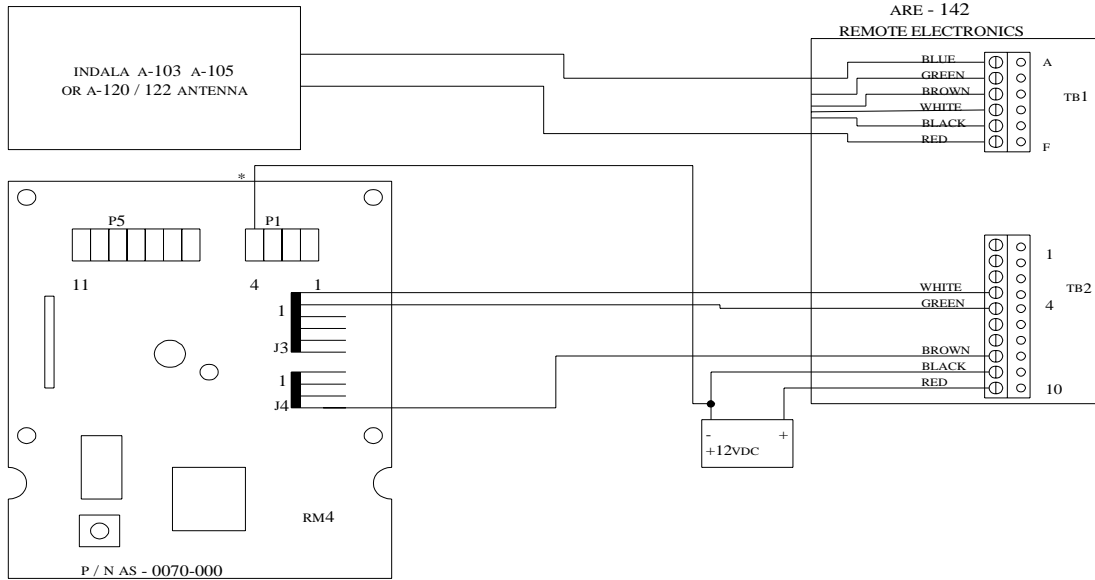


- NOTES:
1. RM AND ISOLATED POWER SUPPLY MUST HAVE COMMON GROUND
  2. SHIELD SHOULD BE CONTIGIOUS AND TIED TO A PROPER EARTH GROUND AT THE DiC / APC
  3. THE LED IS NORMALLY OFF AND SHOWS GREEN FOR A VALID ACCESS AND RED FOR ACCESS DENY
- \*GROUND CONNECTION MAY BE MADE AT EITHER P1 - 4 OR J3 - 5

Figure E.18 Indala Two Wire LED Control Wiring



INDALA ADVANTAGESERIES BI-COLOR READER TO RM WIRING  
FOR SINGLE WIRE LED CONTROL



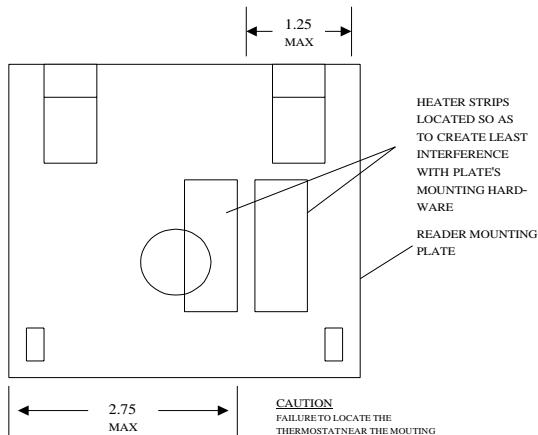
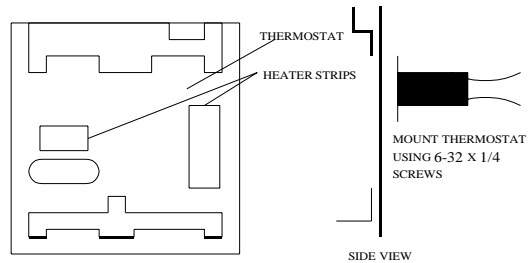
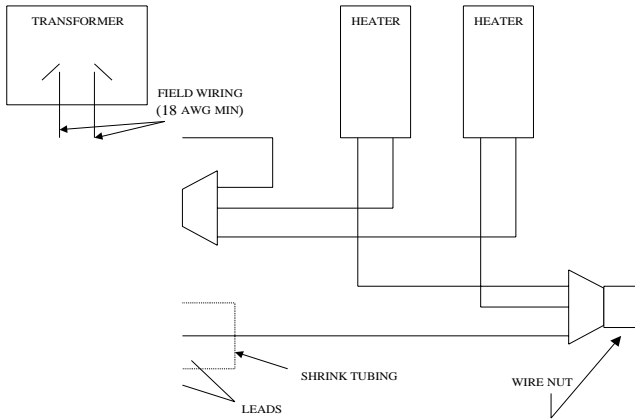
NOTES:

1. RM AND ISOLATED POWER SUPPLY MUST HAVE COMMON GROUND
2. SHIELD SHOULD BE CONTIGIOUS AND TIED TO A PROPER EARTH GROUND AT THE DPC / APC
3. IN THE CONFIGURATION SHOWN, THE LED WILL BE RED AND FLASH GREEN ON A VALID ACCESS

\*GROUND CONNECTION MAY BE MADE AT EITHER P1 - 4 OR J3 - 5

Figure E.19 Indala Single Wire LED Control Wiring

RM / MRM HEATER KIT INSTALLATION (130-915)



HEATER KIT PART # 130-915 CONTAINS THE FOLLOWING PARTS:

- | QTY | ITEM                               |
|-----|------------------------------------|
| 1   | TRANSFORMER 12VAC 40VA             |
| 2   | HEATER STRIPS                      |
| 1   | THERMOSTAT (TURNS ON AT 40 DEG. F) |
| 3   | WIRE NUTS                          |

NOT SUPPLIED: 2 6-32x1/4 SCREWS TO MOUNT THERMOSTAT TO RM PLATE

NOTE: PART # 130-915A IS SUPPLIED WITHOUT A TRANSFORMER

Figure E.20 Heater Kit Wiring

## A P P E N D I X F



# System Specific Information

### In This Appendix

- apC/8X Input/Output Specifications F-2
- apC/8X Number System Specifications F-8
- Setting Software Switches F-15

## apC/8X Input/Output Specifications

Table F.1 describes the Relay Locations and Output Numbering for the apC/8X.

**Table F.1 Relay Locations and Output Numbering for apC/8X with Standard Star Coupler or Wiegand/Proximity Star Coupler<sup>1</sup>**

Relay #	Location	Connector	Used for Elevator Control
1	apC/8X	P1	Yes
2	apC/8X	P2	Yes
3	apC/8X	P3	Yes
4	apC/8X	P4	Yes
5	apC/8X	P5	Yes
6	apC/8X	P6	Yes
7	apC/8X	P7	Yes
8	apC/8X	P8	Yes
9	Star coupler	P1	Yes
10	Star coupler	P2	Yes
11	Star coupler	P3	Yes
12	Star coupler	P4	Yes
13	Star coupler	P5	Yes
14	Star coupler	P6	Yes
15	Star coupler	P7	Yes
16	Star coupler	P8	Yes

**Table F.1 Relay Locations and Output Numbering for apC/8X with Standard Star Coupler or Wiegand/Proximity Star Coupler<sup>1</sup>**

<b>Relay #</b>	<b>Location</b>	<b>Connector</b>	<b>Used for Elevator Control</b>
17	Reader 1	P5 (Relay 1)	
18	Reader 2	P5 (Relay 1)	
19	Reader 3	P5 (Relay 1)	
20	Reader 4	P5 (Relay 1)	
21	Reader 5	P5 (Relay 1)	
22	Reader 6	P5 (Relay 1)	
23	Reader 7	P5 (Relay 1)	
24	Reader 8	P5 (Relay 1)	

1. Relays 9-24 are unavailable when using a Wiegand/Proximity star coupler.

**Table F.2 apC/8X Input Specifications for Standard Star Coupler**

<b>Input #</b>	<b>Location</b>	<b>Connector</b>	<b>Supervised</b>	<b>Used for Elevator Control</b>
1	apC/8X	P9	Yes	Yes
2	apC/8X	P10	Yes	Yes
3	apC/8X	P11	Yes	Yes
4	apC/8X	P12	Yes	Yes
5	apC/8X	P13	Yes	Yes
6	apC/8X	P14	Yes	Yes
7	apC/8X	P15	Yes	Yes
8	apC/8X	P16	Yes	Yes
9	star coupler	P17		Yes
10	star coupler	P18		Yes
11	star coupler	P19		Yes
12	star coupler	P20		Yes
13	star coupler	P21		Yes
14	star coupler	P22		Yes
15	star coupler	P23		Yes
16	star coupler	P24		Yes
17	Reader 1	P5 (8, 9)	Yes	
18	Reader 1	P5 (10, 11)	Yes	

**Table F.2 apC/8X Input Specifications for Standard Star Coupler**

<b>Input #</b>	<b>Location</b>	<b>Connector</b>	<b>Supervised</b>	<b>Used for Elevator Control</b>
19	Reader 2	P5 (8, 9)	Yes	
20	Reader 2	P5 (10, 11)	Yes	
21	Reader 3	P5 (8, 9)	Yes	
22	Reader 3	P5 (10, 11)	Yes	
23	Reader 4	P5 (8, 9)	Yes	
24	Reader 4	P5 (10, 11)	Yes	
25	Reader 5	P5 (8, 9)	Yes	
26	Reader 5	P5 (10, 11)	Yes	
27	Reader 6	P5 (8, 9)	Yes	
28	Reader 6	P5 (10, 11)	Yes	
29	Reader 7	P5 (8, 9)	Yes	
30	Reader 7	P5 (10, 11)	Yes	
31	Reader 8	P5 (8, 9)	Yes	
32	Reader 8	P5 (10, 11)	Yes	

Table F.3 shows the input connections for the Wiegand/Proximity Star Coupler (WPSC).

**Table F.3 apC/8X Input Specifications for Wiegand/Proximity Star Coupler**

<b>Input #</b>	<b>Location</b>	<b>Connector</b>	<b>Supervised</b>	<b>Used for Elevator Control</b>
1	apC/8X	P9	Yes	Yes
2	apC/8X	P10	Yes	Yes
3	apC/8X	P11	Yes	Yes
4	apC/8X	P12	Yes	Yes
5	apC/8X	P13	Yes	Yes
6	apC/8X	P14	Yes	Yes
7	apC/8X	P15	Yes	Yes
8	apC/8X	P16	Yes	Yes
17	WPSC	P8	Yes	
19	WPSC	P7	Yes	



**Table F.3 apC/8X Input Specifications for Wiegand/Proximity Star Coupler**

<b>Input #</b>	<b>Location</b>	<b>Connector</b>	<b>Supervised</b>	<b>Used for Elevator Control</b>
21	WPSC	P6	Yes	
23	WPSC	P5	Yes	
25	WPSC	P19	Yes	
27	WPSC	P18	Yes	
29	WPSC	P17	Yes	
31	WPSC	P16	Yes	

## apC/8X Number System Specifications

Some relay specifications differ depending on what C•CURE system you are using. The following two section discuss the specifications for the C•CURE 1 Plus and C•CURE 750.

Table F.4 shows relay specifications for the C•CURE 750 System.

**Table F.4 C•CURE 750 System Relay Specifications**

Relay #	Location	Connector	Used for Elevator Control
121	Reader 1	P5 (Relay 2)	
122	Reader 2	P5 (Relay 2)	
123	Reader 3	P5 (Relay 2)	
124	Reader 4	P5 (Relay 2)	
125	Reader 5	P5 (Relay 2)	
126	Reader 6	P5 (Relay 2)	
127	Reader 7	P5 (Relay 2)	
128	Reader 8	P5 (Relay 2)	
129	Output Board #1	P1	Yes
130	Output Board #1	P2	Yes
131	Output Board #1	P3	Yes
132	Output Board #1	P4	Yes
133	Output Board #1	P5	Yes
134	Output Board #1	P6	Yes
135	Output Board #1	P7	Yes
136	Output Board #1	P8	Yes

**Table F.4 C•CURE 750 System Relay Specifications**

<b>Relay #</b>	<b>Location</b>	<b>Connector</b>	<b>Used for Elevator Control</b>
137	Output Board #2	P1	Yes
138	Output Board #2	P2	Yes
139	Output Board #2	P3	Yes
140	Output Board #2	P4	Yes
141	Output Board #2	P5	Yes
142	Output Board #2	P6	Yes
143	Output Board #2	P7	Yes
144	Output Board #2	P8	Yes
145	Output Board #3	P1	Yes
146	Output Board #3	P2	Yes
147	Output Board #3	P3	Yes
148	Output Board #3	P4	Yes
149	Output Board #3	P5	Yes
150	Output Board #3	P6	Yes
151	Output Board #3	P7	Yes
152	Output Board #3	P8	Yes
153	Output Board #4	P1	Yes
154	Output Board #4	P2	Yes
155	Output Board #4	P3	Yes
156	Output Board #4	P4	Yes

Table F.4 C•CURE 750 System Relay Specifications

Relay #	Location	Connector	Used for Elevator Control
157	Output Board #4	P5	Yes
158	Output Board #4	P6	Yes
159	Output Board #4	P7	Yes
160	Output Board #4	P8	Yes
161	Output Board #5	P1	Yes
162	Output Board #5	P2	Yes
163	Output Board #5	P3	Yes
164	Output Board #5	P4	Yes
165	Output Board #5	P5	Yes
166	Output Board #5	P6	Yes
167	Output Board #5	P7	Yes
168	Output Board #5	P8	Yes
169	Output Board #6	P1	Yes
170	Output Board #6	P2	Yes
171	Output Board #6	P3	Yes
172	Output Board #6	P4	Yes
173	Output Board #6	P5	Yes
174	Output Board #6	P6	Yes
175	Output Board #6	P7	Yes
176	Output Board #6	P8	Yes

**Table F.4 C•CURE 750 System Relay Specifications**

<b>Relay #</b>	<b>Location</b>	<b>Connector</b>	<b>Used for Elevator Control</b>
177	Output Board #7	P1	Yes
178	Output Board #7	P2	Yes
179	Output Board #7	P3	Yes
180	Output Board #7	P4	Yes
181	Output Board #7	P5	Yes
182	Output Board #7	P6	Yes
183	Output Board #7	P7	Yes
184	Output Board #7	P8	Yes
185	Output Board #8	P1	Yes
186	Output Board #8	P2	Yes
187	Output Board #8	P3	Yes
188	Output Board #8	P4	Yes
189	Output Board #8	P5	Yes
190	Output Board #8	P6	Yes
191	Output Board #8	P7	Yes
192	Output Board #8	P8	Yes

Table F.5 Input Specifications for the C•CURE 750 System

Input #	Location	Connector	Super vised	Used for Elevator Control
65	Input Board #1	P1	Yes	Yes
66	Input Board #1	P2	Yes	Yes
67	Input Board #1	P3	Yes	Yes
68	Input Board #1	P4	Yes	Yes
69	Input Board #1	P5	Yes	Yes
70	Input Board #1	P6	Yes	Yes
71	Input Board #1	P7	Yes	Yes
72	Input Board #1	P8	Yes	Yes
73	Input Board #2	P1	Yes	Yes
74	Input Board #2	P2	Yes	Yes
75	Input Board #2	P3	Yes	Yes
76	Input Board #2	P4	Yes	Yes
77	Input Board #2	P5	Yes	Yes
78	Input Board #2	P6	Yes	Yes
79	Input Board #2	P7	Yes	Yes
80	Input Board #2	P8	Yes	Yes
81	Input Board #3	P1	Yes	Yes
82	Input Board #3	P2	Yes	Yes

**Table F.5 Input Specifications for the C•CURE 750 System**

<b>Input #</b>	<b>Location</b>	<b>Connector</b>	<b>Super vised</b>	<b>Used for Elevator Control</b>
83	Input Board #3	P3	Yes	Yes
84	Input Board #3	P4	Yes	Yes
85	Input Board #3	P5	Yes	Yes
86	Input Board #3	P6	Yes	Yes
87	Input Board #3	P7	Yes	Yes
88	Input Board #3	P8	Yes	Yes
89	Input Board #4	P1	Yes	Yes
90	Input Board #4	P2	Yes	Yes
91	Input Board #4	P3	Yes	Yes
92	Input Board #4	P4	Yes	Yes
93	Input Board #4	P5	Yes	Yes
94	Input Board #4	P6	Yes	Yes
95	Input Board #4	P7	Yes	Yes
96	Input Board #4	P8	Yes	Yes
97	Input Board #5	P1	Yes	Yes
98	Input Board #5	P2	Yes	Yes
99	Input Board #5	P3	Yes	Yes
100	Input Board #5	P4	Yes	Yes
101	Input Board #5	P5	Yes	Yes

Table F.5 Input Specifications for the C•CURE 750 System

Input #	Location	Connector	Super vised	Used for Elevator Control
102	Input Board #5	P6	Yes	Yes
103	Input Board #5	P7	Yes	Yes
104	Input Board #5	P8	Yes	Yes
105	Input Board #6	P1	Yes	Yes
106	Input Board #6	P2	Yes	Yes
107	Input Board #6	P3	Yes	Yes
108	Input Board #6	P4	Yes	Yes
109	Input Board #6	P5	Yes	Yes
110	Input Board #6	P6	Yes	Yes
111	Input Board #6	P7	Yes	Yes
112	Input Board #6	P8	Yes	Yes
113	Input Board #7	P1	Yes	Yes
114	Input Board #7	P2	Yes	Yes
115	Input Board #7	P3		
116	Input Board #7	P4	Yes	Yes
117	Input Board #7	P5	Yes	Yes
118	Input Board #7	P6	Yes	Yes
119	Input Board #5	P7	Yes	Yes
120	Input Board #5	P8	Yes	Yes



**Table F.5 Input Specifications for the C•CURE 750 System**

<b>Input #</b>	<b>Location</b>	<b>Connector</b>	<b>Super vised</b>	<b>Used for Elevator Control</b>
121	Input Board #8	P1	Yes	Yes
122	Input Board #8	P2	Yes	Yes
123	Input Board #8	P3	Yes	Yes
124	Input Board #8	P4	Yes	Yes
125	Input Board #8	P5	Yes	Yes
126	Input Board #8	P6	Yes	Yes
127	Input Board #8	P7	Yes	Yes
128	Input Board #8	P8	Yes	Yes

## Setting Software Switches

Software switches extend the capabilities of the apC/8X, allowing you to program functionality with the C•CURE system you are using.

### **C•CURE 1 Plus Ultra**

To enable second output on an RM reader, set Software Switch 8 to ON. This will disable the first RM 8 Output Module and allow the system to recognize the second RM output.



# I

## Index

### A

Access cards, number of 6-10

Addresses, apC/8X 6-11

Advanced Power Supply (aps) 1-5

Advanced Power System (apS) 3-5

Advanced processing Controller (apC)

- dialup mode 2-18, D-1

Advanced processing Controller (apC/8X)

- addresses 6-11

- anti-passback, enabling 6-10

- battery backup 1-5

- baud rate switches 6-7

- cabling 2-7

- card activation time 6-10

- card deactivation time 6-10

- card number size 6-10

- card storage 2-8

- configuration

  - star/multidrop 4-2

- elevator control switch 6-9

- encrypted magstripe cards 6-11

- event storage 2-8

- external devices and 2-2

- hardware 3-2

- host connection 2-14

- host port wiring 2-14

- input voltage 3-5

- inputs 4-26

- internal power supply limits 2-11

- jumpers 2-15, 6-14

- mounting 3-1–3-7

- multidrop configuration 4-2

- output

  - door forced open 6-8

  - door held open 6-8

  - offline status 6-9

- parity switches 6-8

- power failure input 3-5

- report on misread card 6-9

- software-controlled features 1-2

- star configuration 4-2

- supervised input conditions 1-3

- testing 7-5
- unsupervised input conditions 1-3
- Anti-passback, enabling 6-10
- apC Inputs 4-26
- apC/8X cabinet 3-4
- apC/8X components C-2
- apC/8X Event and Card Storage 2-8
- apC/8X firmware 5-2
- apC/8X Hardware Components 3-2
- apC/8X Input/Output Specifications F-2
- apC/8X LEDs 6-17
- apC/8X Number System Specifications F-8
- apC/8X Optional Modules 1-2
- apC/8X power supply fuse 3-5
- apC/8X Power Supply Limitations 2-11
- apC/8X reader port 4-4
- apC/8X reader ports 4-2
- apC/8X relays 4-22
- apC-I/32 Input Module 5-7
- apC-I/32 Supervised Input Module 1-3
- apC-I/8 Input Bus Module 1-3, 5-19
- apC-I/8 Output Bus Module 5-21
- apC-R/48 Relay Module 1-4, 5-11
  - mounting 5-11
- apC-R/48 relay module 5-11
- apC-R/8 Output Bus Module 1-4
- apCTest Program 7-6
- apCtest program 7-6
- AUX port
  - data transmission format 6-13
- Auxiliary Relay Module 1-7, 4-1

- Auxiliary Relay Module (ARM-1) 1-7, 4-18
  - installing 4-18
  - MOV/diode 4-19

## B

- Battery Backup 1-5
- battery backup power supply 3-5
- Baud rate, apC/8X 6-7
- Baud rates 6-8
- Black Box converter 2-16

## C

- Cabinet tamper override 6-16
- Canadian Radio Emissions Requirements xiv
- Card number size 6-10
- Card Readers 1-6
- Card readers
  - configurations 4-2
  - magnetic stripe 1-6
  - mullion 4-33
  - outdoors 4-34
  - proximity 1-7
  - testing 7-2
  - Wiegand 1-7, 4-33
  - wiring 4-22
- Cards
  - activation time, enabling 6-10
  - deactivation time, enabling 6-10
  - encrypted magstripe 6-11
  - entry through keypad 6-5
- CE Compliance xv
- class A supervised inputs 1-6

communications LEDs 6-19

configure modems D-2

Configuring apC/8X Jumpers 2-15

Configuring Modems with Software D-3

Connecting the apC/8X to a Host 2-14

Connectors

    I/8 Module

        P9, port, illustration 5-20

    R/8 Module

        P9, port, illustration 5-21

## D

Data transmission format, AUX port 6-13

Dialup mode

    configuring 6-8, D-1

    modem parity switch 6-8

    setting switch for 6-7

dialup mode D-1, D-9

Diode 4-19

DIP switch settings for modems D-3, D-5, D-6

DIP switches D-2

Door forced open, output on 6-8

Door held open, output on 6-8

duress feature 6-11

Duress, disabling 6-11

## E

earth ground 3-5

electrostatic discharge 4-30

electrostatic discharge (ESD) 5-2

Elevator

    control 6-9

    keypad use 6-9

    switches 6-10

Elevator control 6-9

Encrypted magstripe cards 6-11

Environmental Specifications A-6

EOL

    I/8 Module

        W1, illustration 5-20

    R/8 Module

        W1, illustration 5-21

EPROMs

    replacing 2-19

    switches for type 6-13

Equipment Wiring Requirements 2-4

Event storage 2-8

External Devices and the apC/8X 2-2

## F

fail-safe mechanism override xvi

FCC Class A xiii

FCC Class B xiii

## H

Hayes Modem D-2

Heater kit, installing 4-36

Host port

    communications protocol 6-16

    wiring 2-14

Host Port Communication Protocol 6-16

**I**

## I/8 Module

- P9, port connector, illustration 5-20
- SW1, address switch, illustration 5-20
- tamper switch input
  - illustration 5-20, 5-21
- W1, EOL terminator, illustration 5-20

## I8 Input Module 5-19

## I8 Input Modules 4-4

## Input voltage 3-5

## Inputs 1-2

- apC/8X 4-26
- card numbers through keypad 6-10
- numbering 4-26
- supervised 4-25, 4-26
- typical wiring for 4-25
- unsupervised 1-3

## Insertion reader 1-6

## inside door template C-1

## Installation test procedures 7-1

## Internal power supply limits 2-11

**J**

## Jumper settings 6-14

**K**

## Key reader 1-6

## Keypad installation

- card number through 6-10
- elevator 6-9

**L**

## leased telephone lines D-1

## lease-line configuration D-2

## LED bar 6-20

## LEDs

- test indications 7-2
- two wire control for readers 4-14

**M**

## Magnetic stripe reader

- LED indicators 7-4
- test procedure 7-2

## Magnetic Stripe Readers 1-6

## Material Support Center C-1

## Memory

- requirements 2-9–2-10
- size 2-8

## Mini Star Coupler 1-2, 1-4

## Mini star coupler 1-4

- installing 5-3

## Misread cards 6-9

## Modems

- computer cable connection to host D-6
- configuring for use with dialup lines D-3
- configuring for use with leased lines D-4
- dialup D-1
- DIP switch settings D-9
- directly connected 2-17
- hyperterminal edits for 4-wire leased lines
  - D-6
- software commands for configuring D-9
- switch settings
  - for 2-wire leased lines D-5

- for 4-wire leased lines D-6
- for dialup D-3
- wire diagram D-9

- Modems for dialup mode apC/8Xs 2-18
- Modems for directly connected apC/8Xs 2-17
- Mounting the apC/8X Cabinet 3-3
- MOV 4-19
- Multidrop Configuration 4-9
- Multidrop configuration 4-4
- multidrop configuration 4-6

## N

- non-warranty repairs C-1

## O

- OEM modem D-2
- Offline output 6-9
- onboard tamper switch 1-6
- Operating Environment A-2
- Optional equipment ??-4-38, ??-4-38
- Optional Heater Kit 4-36
- Optional input ground 6-16
- Optional modules 1-3
  - apC-I/32 Input 5-7
  - apC-R/48 Relay 5-11
  - Wiegand/proximity star coupler 5-5
- Output Numbering F-2
- Outputs
  - AC door strike and 4-22
  - DC locking mechanism and 4-22
  - numbering 4-23

- R/8 Module
  - illustration 5-21
  - relays and 4-22

- Override tamper 6-16

## P

- packing an apC/8X unit C-1
- Packing and shipping instructions C-1
- Paired Readers 1-7
- Paired readers 1-7
- Parity, apC/8X 6-8
- Personal Identification Number (PIN)
  - elevator and 6-9
- plenum-rated cables 2-7
- Power failure input 3-5
- Power Supply Limits 2-12
- pre-programming commands D-10
- Proximity reader 1-7
- Proximity Readers 1-7
- Push button, reset 6-13

## R

- R/8 Module
  - outputs, illustration 5-21
  - P9, port connector, illustration 5-21
  - SW1, address switch, illustration 5-21
  - W1, EOL, illustration 5-21
- R8 Output Module 5-21
- R8 Output Modules 4-4
- Reader Configuration Switch Settings 4-16
- Reader Power Selection 4-11

- Relay Locations F-2
  - relay locations 5-14
  - relay specifications F-8
  - relay specifications for the C<sup>2</sup>CURE 750 System F-8
  - Relays
    - for magnetic locks 4-22
    - setting up 5-14
    - typical wiring for 4-22
  - Replacing the apC/8X EPROM 2-19
  - Reset switch 6-13
  - Return Authorization Number C-1
  - Returning equipment, instructions for C-1
  - RM Input Module 5-19
  - RM LEDs 7-4
  - RM Optional Modules 5-19
  - RM optional modules 5-19
    - installation considerations 5-22–5-27
    - setting addresses for 5-27
  - RM Output Module 5-21
  - RM personality board 4-1
  - RM reader 4-2
  - RM Reader Bus 1-4
  - RM series card reader configuration A-5
  - RM Series Card Reader Configurations A-5
  - RM-4
    - mounting 4-34
    - outdoor use 4-34
    - personality board 4-30
    - wire length B-1–B-6
  - RM-4 personality module 4-30
  - Rotary switches 6-11
  - RS-232 connection 2-15
  - RS-232 format 2-14, 6-15
  - RS-232C communication protocol 2-15
  - RS-232C to RS-485 converter 2-16
  - RS-485 2-16, 6-15
  - RS-485 communication protocol 2-15
- ## S
- Setting Software Switches F-15
  - Setting the apC/8X Switches 6-4
  - Setting Up a Reader 4-15
  - shipping it in for repair C-1
  - Software-Controlled Options 1-2
  - SRAM size 2-8
  - Standard Star Coupler 1-4, 4-10
  - Star Coupler 1-2
  - Star coupler
    - installing 5-3
    - mini 1-4
    - standard 1-4, 4-10
    - unsupervised inputs 1-3
    - Wiegand/proximity 1-4, 4-10
  - static RAM 1-2
  - static shield containers C-2
  - Storing cardholder information 2-8
  - Supervised inputs 4-25
  - Swipe reader 1-6
  - Switch table for addresses 6-11
  - Switches
    - apC/8X addresses 6-11
    - baud rate 6-7
    - card number size 6-10
    - card numbers through keypad 6-10



- dialup modem 6-7
- door forced open 6-8
- door held open 6-8
- duress 6-11
- elevator 6-10
- elevator control 6-9
- encrypted magnetic stripe 6-11
- EPROM 6-13
- for elevator control 6-10
- I/8 Module
  - SW1, address switch, illustration 5-20
- keypad for elevator 6-9
- LED 6-10
- modem parity 6-8
- offline status 6-9
- R/8 Module
  - SW1, address switch, illustration 5-21
- report on misread card 6-9
- reset 6-13
- RS-485 6-15

## T

- Tamper override 6-16
- Tamper Switch 5-26
- tamper switches 1-2
- Termination Resistors 5-24
- Terminator 4-28
- Test procedures 7-1
- Testing Readers 7-2

## U

- UL Listing xiii
- UL294 requirements 4-18
- Unsupervised inputs 1-3
- UPS connector 3-5

- US Robotics modems D-2

## V

- Varistor 4-19

## W

- W1
  - I/8 EOL terminator
    - illustration 5-20
  - R/8 EOL terminator
    - illustration 5-21
- Wiegand Readers 1-6
- Wiegand readers 4-33
  - dimensions and weights A-3
  - test procedure 7-5
  - types 1-6
- Wiegand/Proximity Star Coupler 1-4
- Wiegand/proximity star coupler 5-5
- Wiegand/Proximity Star Coupler (WPSC) 4-10, 5-5, F-6
- Wiring readers 4-22–4-29