

ADACSNET USB Control Module

Installation Guide

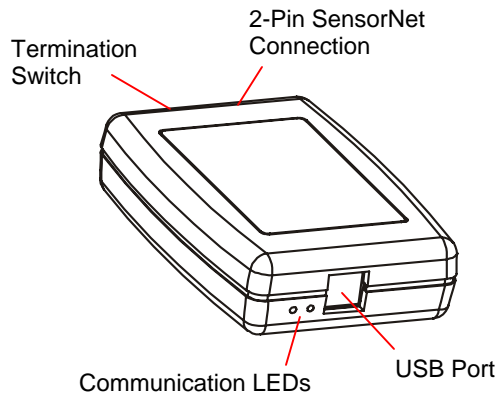

The USB Control Module allows a host computer such as an Intellex digital video management system (or a PC with a USB port) to control one or more American Dynamics camera domes using the SensorNet (RS485) communication protocol.

This guide explains:

- Features of the module and basic hookup
- Information required to download special software, if required
- SensorNet Rules and network types.

Features and Hookup

The USB Control Module contains the following:

- **USB port:** Connects to the host computer.
- **Communication LEDs:** A yellow LED indicates correct USB connection by glowing steadily or blinking. Immediately after power is turned on, a green LED glows steadily for about 3 seconds then turns off. This LED also blinks every time a data packet is sent to the camera dome.
- **Termination switch:** Termination is indicated by a resistor symbol near the switch. See "SensorNet Rules and Network Types" in this document for when to set the switch.

The following diagram shows how to hook up the control module between the host (Intellex or PC) and a camera.

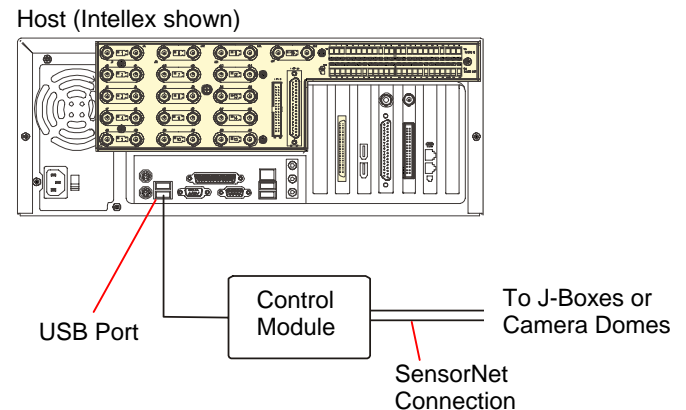

Software Installation for Non-Intellex Systems

If not connecting the module to an Intellex system, special drivers and utilities software must be downloaded to your personal computer that enable its use. *USB Control Module Software Utilities User Guide 8200-0310-02* explains how to download this software. To obtain this guide:

1. On the internet, go to <http://www.americandynamics.net> and select "Software Downloads".
2. Click on the USB Control Module picture.
3. Download *USB Control Module Software Utilities User Guide 8200-0310-02*.

SensorNet Rules and Network Types

The SensorNet communication protocol allows the host computer and camera domes to exchange data along a cable network (star, daisy chain, or backbone).

SensorNet Rules

- A star network cannot have more than four branches, one line termination per branch
- A backbone network has a termination at each end of the line
- A SensorNet line cannot have more than 32 network-compatible devices
- A network cannot have more than four repeaters in the path of any two camera domes
- A SensorNet line or branch cannot exceed 1km (3300ft). Use signal repeaters only when exceeding the maximum distance or noise is an issue
- Signal levels for SensorNet-compatible devices are from 0.3–5V (1–5V is recommended).

Network Types

Star Network

The star network allows you to relocate devices. However, this network is not recommended in high noise environments because the extra terminations required will lower the signal to noise ratio.

A separate cable line (branch) runs from the USB module to each device. Limit branches to four.

The example below shows the USB module as the hub of a star network. The module is not terminated.

Black box = USB module, T = Terminated

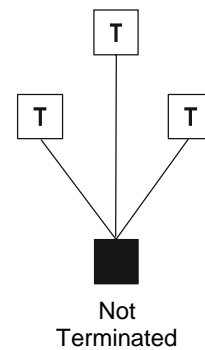

Daisy-Chain/Backbone Network

Use a daisy chain network if the cable is to be short, extended in the future, or when USB module and camera domes are in the same room. In a daisy chain, a separate cable connects every two adjacent devices along the chain. Daisy chaining makes it easy to add devices by extending the network from a nearby device. The USB module can connect anywhere along the cable.

Use a backbone network if the cable is to be long and permanent. This network type operates the same as the daisy chain, but uncut wires may be more conductive and reliable. In a backbone, a single cable is used. Along the cable, 2.5cm (1in) sections are stripped, bent, and connected to each remote device. The USB module can connect anywhere along cable.

The example below shows the USB module at end of a daisy chain or backbone network. The module and the last camera dome in the chain are terminated.

Black box = USB module, T = Terminated

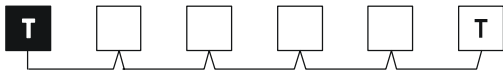

The example below shows the USB module inserted in a daisy chain or backbone network. Camera domes on both ends of the chain are terminated; the module is not.

Black box = USB module, T = Terminated

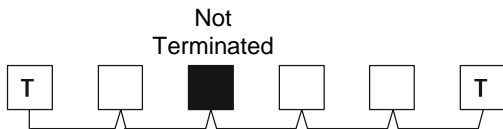

When J-boxes are Used

When using the USB control module with J-Boxes, consider the following rules (also refer to the following diagram):

- Only use the AUX-to-HOST connection if the distance from the HOST to the last J-BOX is more than 1km (3300ft). Repeating is not needed when the USB module and the last J-BOX are less than 1km (3300ft) apart.
- From J-BOX 1 to J-BOX 2, use the HOST-to-HOST connection only when the distance from the HOST and the last J-BOX is less than 1km (3300ft).
- If using the J-BOX to amplify the signal, it is best to install it between 500 and 750m (1600-2500ft).
- Balance connection ports with domes (do not load on one side).

SensorNet Cable

SensorNet data cable. For plenum applications, use RPPS series cable. For non-plenum applications, use RPDS series cable.

Composite cable. For plenum applications, use RPPCS series cable. For non-plenum applications, use RPNCS series cable.

For further details, see *Product Guide* at: http://www.americandynamics.net/products_Catalog.asp

Note: In some environments, high noise on the network may limit cable distance to less than 1km (3300ft).

Note. Sensormatic composite cable is recommended. This cable contains wires for power and video. If another cable is substituted, wire colors may be different.

If shielded cable must be used, signals may rapidly decline as more devices are connected or its length increases. As a result, maximum length for shielded cable is reduced. For example, maximum length for Belden 8760 cable is 750m (2500ft) in ideal conditions (no noise).

USB with J-Boxes

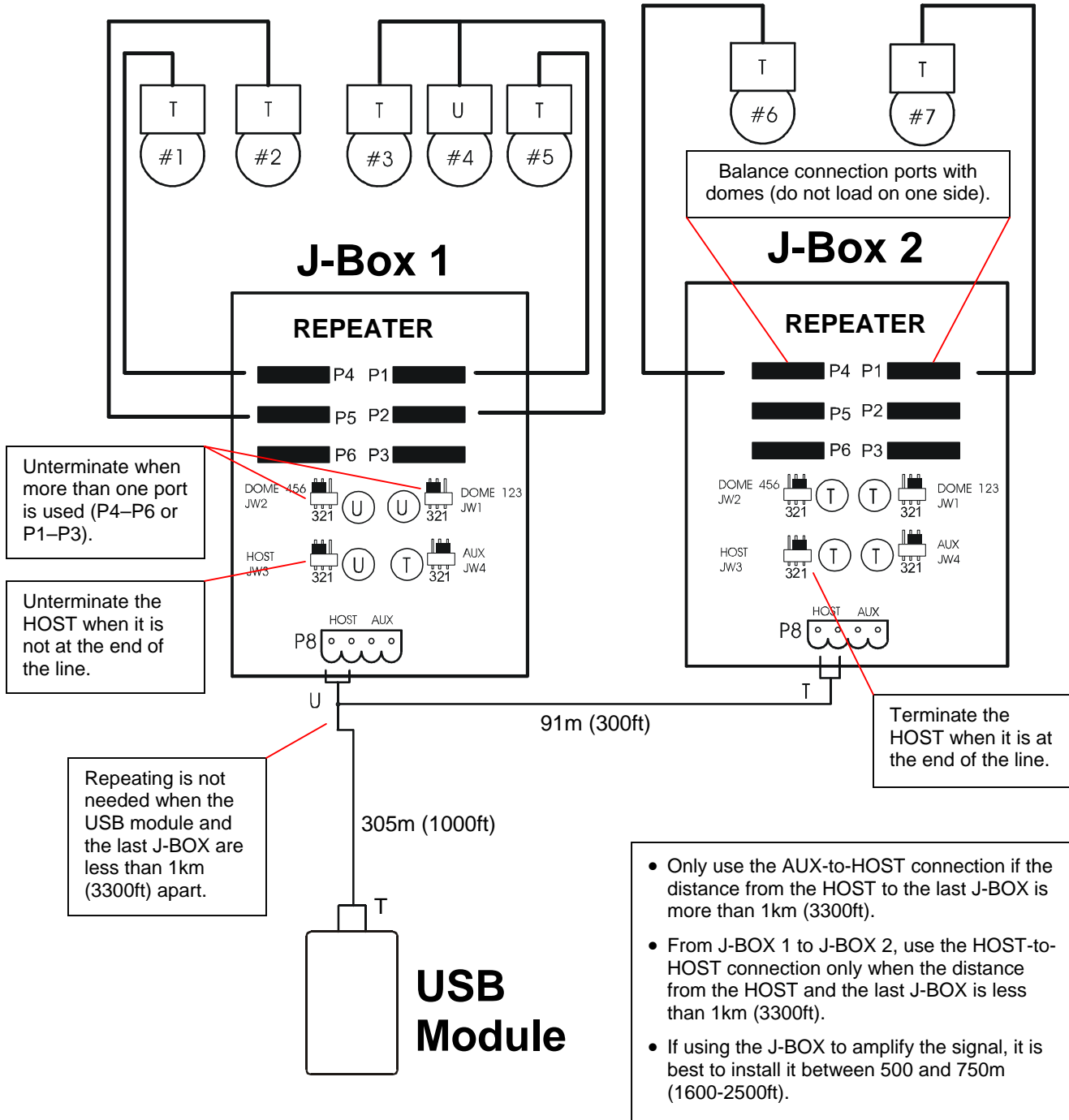

Specifications

USB Specifications

Bit rate	1.5Mb/s Low Speed, 12Mb/s Full Speed
Maximum cable length.....	3m (9.8ft) for 1.5Mb/s, 5m (16.4ft) for 12Mb/s
Specification	Universal Serial Bus USB Specification Revision 1.1
Connector	USB Type B receptacle
Power source.....	From USB host controller port (power adaptor not required)

SensorNet Specifications

Address range	1 to 254 (configurable)
Bit rate	230.4Kbps
Network distance	1km per node
Maximum loads.....	32 per node
Node repeaters.....	SensorNet junction boxes
Topologies supported	Daisy chain, Backbone, or Star
Transmission medium.....	Single non-polarized unshielded twisted pair UTP 22AWG
Connector	Euro-style 2 pin removable plug 3.5mm terminal block
Terminating resistor	120 ohms, switch selectable
Physical layer	RS-485, transformer isolated, 2-wire
Data encoding	FM-0
Link layer framing	SDLC/HDLC
Link layer channel.....	Bi-directional, half duplex
Collision avoidance.....	Polling by USB Module
Application protocol	Proprietary
Network nodes.....	Domes, junction boxes, secondary TouchTracker™, and SensorNet I/O unit

Power

Input voltage	5.0Vdc ±5%, 0.75W
Internal voltage (CPU + Misc. Support).....	3.3Vdc ±5%

Surge Protection

SensorNet:

Gas discharge tube impulse rated at:

DC breakdown voltage.....	90V
Insulation resistance	10,000 Mega ohms
Capacitance	2pF max.
8/20µs impulse discharge current	10kA
Ten 8/20µs impulses discharge current	5kA
Isolation transformer coupled	2000Vrms
PTC re-settable fuse protects transformer	
Transient voltage suppressors (TVS):	
Break down voltage	7.6–9.3V
Peak current.....	40A
Capacitance	2000pf @ 1kHz

USB: ESD suppressors protect USB lines by suppressing fast rising transients as specified in IEC 61000-4-2 and MIL-STD-883C (8kV discharge method).

Environmental

Operating Temperature:.....	10° to 50°C (14° to 122°F)
Relative Humidity:	0 to 95% non-condensing

Mechanical

Length	10.2cm (4in)
Width.....	7cm (2.8in)
Thickness	2.5cm (1in)
Weight.....	0.5kg (1.1 lbs)

Declarations

Regulatory Compliance

EMC.....	47 CFR, Part 15 ICES-003 EN55022 CISPR 22
Safety	UL 1950 CSA C22.2 No 950 TUV Rhienland EN60950 IEC 950

FCC COMPLIANCE: This equipment complies with Part 15 of the FCC rules for intentional radiators and Class A digital devices when installed and used in accordance with the instruction manual. Following these rules provides reasonable protection against harmful interference from equipment operated in a commercial area. This equipment should not be installed in a residential area as it can radiate radio frequency energy that could interfere with radio communications, a situation the user would have to fix at their own expense.

EQUIPMENT MODIFICATION CAUTION: Equipment changes or modifications not expressly approved by Sensormatic Electronics Corporation, the party responsible for FCC compliance, could void the user's authority to operate the equipment and could create a hazardous condition.

Other Declarations

Thank you for using American Dynamics products. We support our products through an extensive and worldwide network of dealers. The dealer, through whom you originally purchased this product, is your point of contact if you have a need for service or support. Our dealers are fully empowered to provide the very best in customer service and support. Dealers should contact American Dynamics at (800) 507-6268 or (561) 912-6259 or on the web at www.americandynamics.net.

WARRANTY DISCLAIMER: Sensormatic Electronics Corporation makes no representation or warranty with respect to the contents hereof and specifically disclaims any implied warranties of merchantability or fitness for any particular purpose.

NOTICE: The information in this manual was current when published. The manufacturer reserves the right to revise and improve its products. All specifications are therefore subject to change without notice.

LIMITED RIGHTS NOTICE: For units of the Department of Defense, all documentation and manuals were developed at private expense and no part of it was developed using Government Funds. The restrictions governing the use and disclosure of technical data marked with this legend are set forth in the definition of "limited rights" in paragraph (a) (15) of the clause of DFARS 252.227.7013. Unpublished - rights reserved under the Copyright Laws of the United States.

TRADEMARK NOTICE: *American Dynamics* and *Sensormatic* are trademarks or registered trademarks of Sensormatic Electronics Corporation. Other product names mentioned herein may be trademarks or registered trademarks of Sensormatic or other companies.

COPYRIGHT: Under copyright laws, the contents of this manual may not be copied, photocopied, reproduced, translated or reduced to any electronic medium or machine-readable form, in whole or in part, without prior written consent of Sensormatic Electronics.

MDR 03/2004