

SpeedDome® Ultra 8 Camera Dome

Installation and Service Guide

Figure 1. SpeedDome Ultra Camera Dome

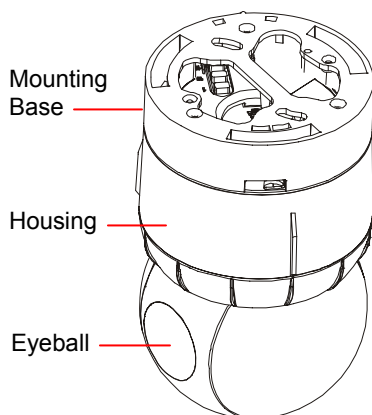

Camera Dome Product Codes

Product	Description
ADSDU822N	22X, N, VERSION 1.00, BLACK
ADSDU822P	22X, P, VERSION 1.00, BLACK
ADSDU822WN	22X, N, VERSION 1.00, WHITE
ADSDU822WP	22X, P, VERSION 1.00, WHITE
ADSDU835N	35X, N, DAY/NIGHT, VERSION 1.00, BLACK
ADSDU835P	35X, P, DAY/NIGHT, VERSION 1.00, BLACK
ADSDU835WN	35X, N, DAY/NIGHT, VERSION 1.00, WHITE
ADSDU835WP	35X, P, DAY/NIGHT, VERSION 1.00, WHITE

Contents

About this Guide	1
About the Camera Dome	2
Cable Requirements	7
Install/Removal Tool for Base with I/O Board	8
Power-Up Routine.....	8
Synchronizing Domes	8
Diagnostic LEDs	8
Warnings and Cautions	9
Indoor Installation.....	10
Using the Install/Removal Tool	14
Troubleshooting Indoor Domes	16
Parts List for Authorized Users	25
Specifications-Indoor Dome.....	27
Declarations	29
Appendix A: Vicon Wiring Configurations	30

About this Guide

This guide explains how to connect the camera dome to a mounting base and how to service it.

It does not explain how to:

- Determine a mounting location for the camera dome. The mounting location is determined by customer requirements; therefore, this information is provided separately.
- Attach the mounting base. See information shipped with the base.
- Assemble housings and structures used with this camera dome. See information shipped with the housing and structure.
- Program the camera dome. See operator's guide shipped with the dome.

About the Camera Dome

The SpeedDome Ultra 8 camera dome (Figure 1):

- Mounts indoors, or outdoors (with accessory outdoor enclosure)
- Communicates with the video controller over a SensorNet 485, RS-422, Manchester, or UTC (up-the-coax) network
- Consists of a mounting base, housing, and rotating eyeball assembly.

Mounting Base

The housing and eyeball assembly connect to the base using a twist and lock action (Figure 2), enabling it to be moved easily from one location to another. The base:

- Attaches directly to a tile or hard ceiling, or indirectly to walls or ceilings using one of many optional housings and mounting structures
- Contains an I/O circuit board to which video, data, and power cables connect
- Has four alarm inputs and three alarm outputs.

Housing and Eyeball Assembly

The housing and eyeball assembly consists of the following:

The housing contains the dome's power supply, pan motor, and electronics used to operate the eyeball.

The eyeball:

- Has a diameter of 120mm (4.75in).
- Contains a camera, tilt motor, and associated electronics.
- Enables the camera to pan and tilt to track a target moving in any direction even as it moves under the dome.
- Has two slot covers to facilitate access to the camera, one of which incorporates an opening for the camera lens.

Note: Remove both covers to improve ventilation when the dome is used outdoors.

Figure 2. Mounting base and housing and eyeball assembly

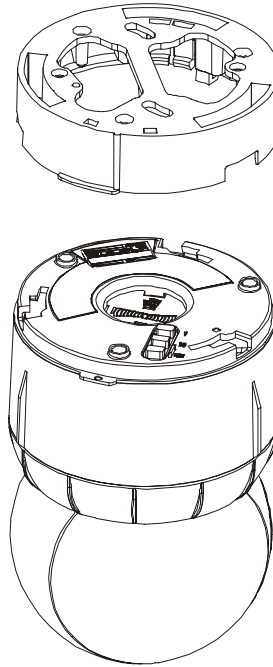

Indoor Ceiling Mounting

The camera dome attaches directly to indoor ceilings made of sheet rock, wood, metal, or concrete (Figure 3) using hardware shipped with the base.

Figure 3. Surface mounting to hard ceilings

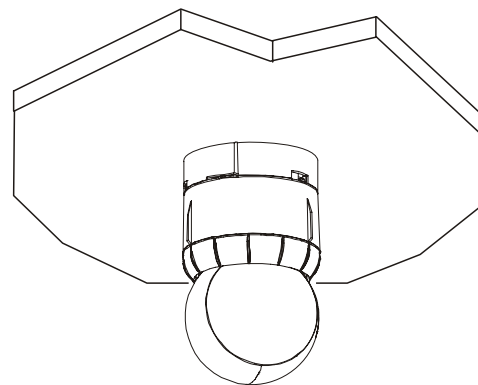

Indoor Ceiling/Wall Mounting (Optional)

The camera dome attaches to one of the following optional indoor mounting structures (Figure 4).

Sheet Rock, Concrete, Plaster or Wood Ceilings

RHIUTH	Top hat housing with trim ring. This housing attaches to a ceiling or to most indoor mounting structures. A trim ring and optional magnetic bubble provide concealment. Optional bubbles: RUCLR (clear), RUSLV (silver), RUSMK (smoked), or RUGLD (gold). Dome base included.
RHIUHC	Hard ceiling bracket. Enables top hat housing to be recessed in ceiling (requires top hat RHIUTH). Can be installed from below ceiling.
RHIUFB	Fixed bracket. Enables top hat housing to be recessed in ceiling (requires top hat RHIUTH). Requires access from above ceiling.
RHIUPNDT†	Pendant mount. Suspends dome from a hard ceiling with 3.2cm (1 1/4in) NPT pipe fittings.

Structural I-Beams

RHIUIB / RHIUIBM†	I-beam mount only. Enables dome suspension from an I-beam. RHIUIBM version has all related accessories to suspend from I-beam, except 3.2cm (1 1/4in) NPT pipe.
-------------------	---

Electrical Box in Ceiling

RHIU3X3	3 X 3 mounting plate. Attaches dome to a standard 3.5 x 3.5 duplex electrical box. CAUTION: Do not use the same electrical box used for line voltage mains.
RHIU4X4	4 X 4 mounting plate. Attaches dome to a standard 4 x 4 duplex electrical box. CAUTION: Do not use the same electrical box used for line voltage mains.

* Option in white, but can be painted to match decor.
† Top hat housing/dome assembly also mounts to structure.

Tile Ceilings

RHIUFB	Fixed bracket. Enables top hat housing to be recessed in a 2x2 tile (requires top hat RHIUTH).
RHIUAB	Adjustable bracket. Enables top hat housing to be recessed in a 2x4 tile (requires top hat RHIUTH).
RHIU2X2M*	2 X 2 metal tile mount. Enables top hat housing to be recessed in 2x2 openings (includes top hat housing).
RHIU2X2P*	2 X 2 metal tile pendant mount. Enables dome to be suspended from 2x2 openings. Requires 3.2cm (1 1/4in) NPT pipe (allow 3m (10ft) max. length). Accepts the following housings: RHIOTH, Dome base.

* Option in white, but can be painted to match decor.
† Top hat housing/dome assembly also mounts to structure.

Wall Mounting

RHIUCM*	Wall mount with corner feature. Enables dome to attach to a flat wall, inside corner, or outside corner.
RHIULWM*†	Long 60cm (24in) wall mount. Positions dome away from wall to enable it to see over furniture, shelving, and displays. This mounting structure attaches to the flat wall, inside corner, or outside corner.

* Option in white, but can be painted to match decor.
† Top hat housing/dome assembly also mounts to structure.

Outdoor Mounting (Optional)

Note: This document does not include installation and service instructions for the AD outdoor housing. These instructions are supplied with the housing.

The camera dome attaches to outdoor walls and ceilings using an AD outdoor housing (Figure 5) and an ROENDC end cap connected to one of the following optional mounting structures (Figure 7).

- RHOTR Over Roof Mount
- RHOTRF Over Roof Floor Mount
- RHOPN Pendant Mount
- RHOWPA Pole Mount
- RHOSW/RHOLW Wall Mount
- RHOWCA Corner Bracket.

The outdoor housing contains a pre-installed mounting base, a cooling fan for hot weather, a heater for cool weather and to prevent icing, and surge protection circuitry.

An environmental PC board is used to pre-wire cables. A round spring-finger connector on the board makes electrical contact with the housing and eyeball assembly as it connects to the base.

Note: Do not use the I/O board (designed for indoor use) in place of the environmental board.

Figure 5. AD outdoor housing (optional)

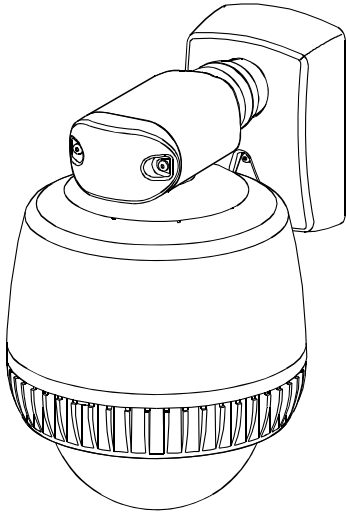

SpeedDome Housing Adapter Bracket (Optional)

An RHSDA adapter bracket (Figure 6) enables the dome to fit into SpeedDome indoor housings (RD500A). Locking pins in the bracket enable the dome to swing out for servicing or removal.

Figure 6. RHSDA adapter bracket (used with the RD500A housing)

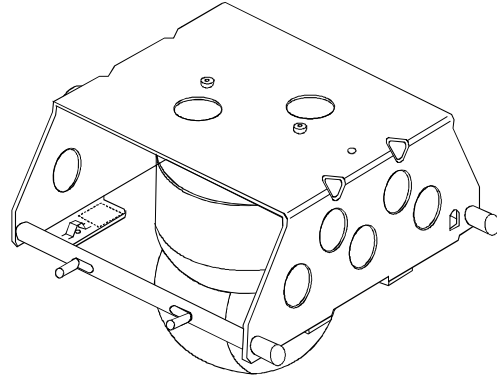
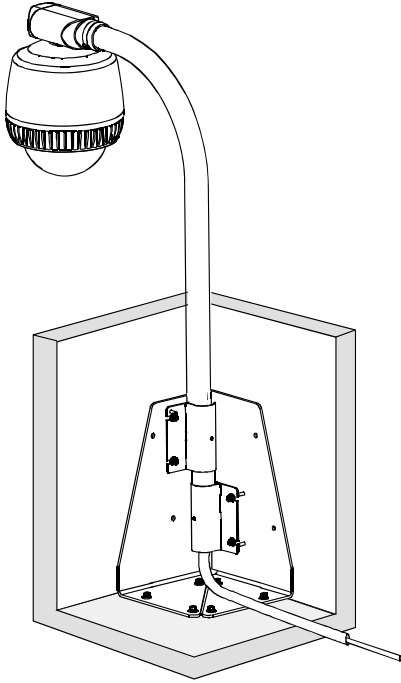

Figure 7. Outdoor mounting structures (optional).

Note: Housing is shown for reference only.

RHOTR over roof mount comes with the ROENDC end cap (shown with RHOTRF bracket)



ROENDC end cap

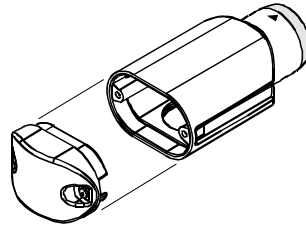

RHOWPA pole mount comes with the ROENDC end cap

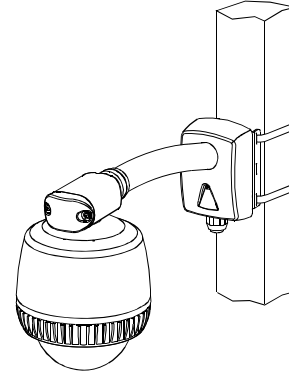

RHOSW/RHOLW wall mount comes with the ROENDC end cap

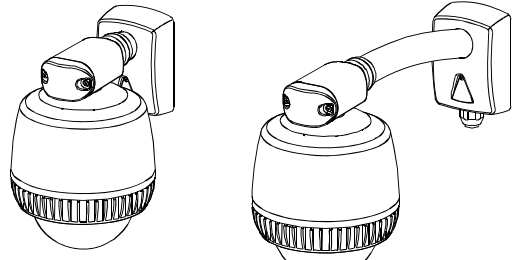

RHOSW

RHOLW

RHOPN pendant mount

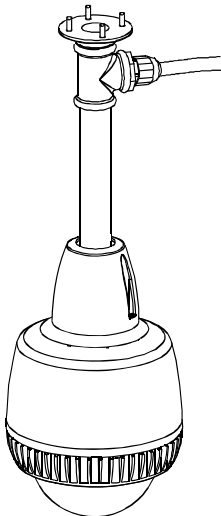

RHOWCA corner bracket only (shown with RHOLW mount)

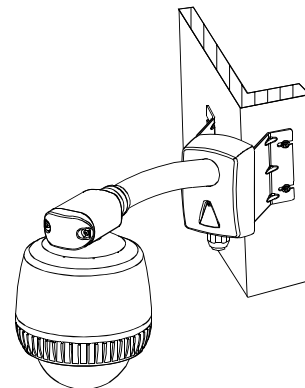

Cable Requirements

Data Cable

The table below shows requirements for SensorNet, RS-422, and Manchester networks. For more information about communication protocols and cable networks, see *Communication Protocols and Cable Networks*, 8000-2573-19.

Data cable requirements

	SensorNet	RS-422	Manchester
Cable type	1 unshielded, twisted pair*	2 shielded, twisted pair*	1 shielded twisted pair**
Wire gauge	22 AWG	22 AWG	18 AWG
Connection	Non-polarized	Polarized	Polarized
Max. devices on line	32	10	3

* Power, data, and video cables can be ordered separately or within a composite cable that can be ordered in various lengths. Plenum-rated cables must be used in indoor ceilings used for environmental air return (called "other air space" in the National Electrical Code). Order parts through your distribution network.

Note: If you order cable from an outside source, wire colors may be different.

** Belden 88760 (plenum), or Belden 8760 cable (non-plenum) cable is recommended. Plenum-rated cables must be used in indoor ceilings used for environmental air return (called "other air space" in the National Electrical Code). Order cable directly from Belden by calling 1-800-235-3361.

Power Cable

For the camera dome to operate properly, line voltage must not go below the worst-case low line voltage shown in the following table. Make cable lengths as short as possible to minimize the affects of low line voltages.

As shown in the table, the maximum cable length depends on the Class 2 LPS (low voltage) ac source (such as a J-box) and the worst-case low line voltage. These lengths are for Sensormatic composite cables, which use 18 AWG ac power wires.

Note: Typically, distances are used that provide a 15% margin between nominal and low line conditions. For example, if the nominal voltage is 120Vac, restrict cable length to that associated with 100Vac (0.85 x 120).

Worst-case ac line voltages

Indoor Dome AC Power Source	Worst-Case Low Line V	Meters (Feet)
28 VA Transformer 5604-0006-01	117	180 (600)
	100	130 (430)
	90	80 (270)
50 VA Transformer 5604-0044-01	117	180 (600)
	100	150 (500)
	90	90 (300)
Outdoor 1-position SensorNet RJ1SNUD	117	210 (700)
	100	130 (430)
	90	100 (325)
Outdoor (PAL) 1-position SensorNet RJ1SNUD-1	240	210 (700)
	200	130 (430)
	180	100 (325)
6-position SensorNet Indoor J-Box RJ6SN	117	300 (1000)
	100	230 (750)
	90	160 (530)
	240	300 (1000)
	200	230 (750)
	180	160 (530)
10-Position RS-422 Indoor 120V/60Hz J-Box RJ860AP	117	275 (900)
	100	200 (650)
	90	130 (430)
10-Position RS-422 Indoor 240V/60Hz J-Box RJ860AP1	240	275 (900)
	200	200 (650)
	180	130 (430)
Universal Transformer 0300-0914-01	117	200 (650)
	100	130 (430)
	90	90 (300)
Universal Transformer 0300-0914-03	240	200 (650)
	200	130 (430)
	180	90 (300)

Install/Removal Tool for Base with I/O Board

The install/removal tool (Figure 8) enables you to connect or disconnect the housing and eyeball assembly from the mounting base, and to attach/detach skirts and bubbles from a top-hat housing, without the need for a ladder. The tool attaches to a telescopic pole (purchased separately). See page 14.

CAUTION: Do not use this tool to connect the dome to the base without I/O board.

Figure 8. RHIRT indoor install/removal tool

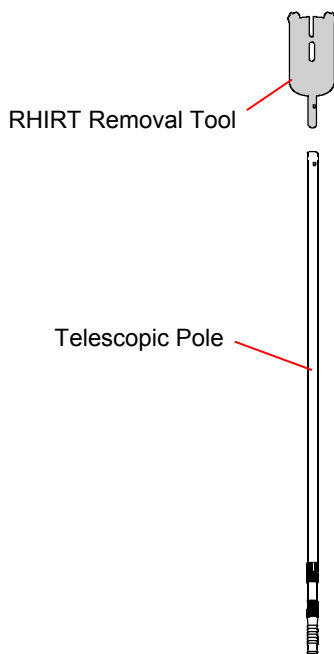

Power-Up Routine

After power is connected to the dome, the dome performs the following homing routine.

After a few seconds, the camera lens tilts up into the housing and eyeball assembly and then tilts down until it looks at the floor. While doing this, the eyeball pans fast in one direction to find the approximate home position, then pans slowly to find the exact home position.

Note: If this is the first time power was connected to the dome, the dome will home to these coordinates: 90° tilt, 0° pan. Otherwise, the dome will home to the position it was in when last powered down.

Once the lens is in its home position, the controller can be used to call up the camera and control it.

Synchronizing Domes

To prevent picture rolling when switching from camera to camera, all domes can be synchronized to a 50Hz or 60Hz ac source.

A V-phase adjustment at the control console enables the dome to sync to any line phase.

Diagnostic LEDs

LEDs on the underside of the mounting base enable you to check for power and data.

If an RS-422 network is used, other LEDs on the board indicate that wiring is correct, reversed, open, or grounded.

Warnings and Cautions

Please review the following warnings and cautions before you begin installation or service.

WARNINGS



WARNING!

ALWAYS USE:

- Proper safety equipment for the location and type of installation.
- Proper lift equipment to reach the installation.
- Safety features of the lift equipment.

BE SURE:

- Electrical power is not connected to the dome when connecting wires. Dome will move when power is applied.
- Electrical power is not connected to nearby fixtures that you might touch during installation.



WARNING! DO NOT install this camera dome where highly combustible or explosive products are stored or used.



WARNING! This dome runs on 24Vac. DO NOT connect line voltage to this dome.

North America power requirements: In North America, this device is intended to be supplied from a Class 2 power supply. For outdoor installations, use Class 3 wiring techniques, liquid-tight conduit, or liquid-tight pipe.

This installation should be made by a qualified service person and should conform to all local codes.



WARNING!

EU power requirements: This product runs on 24Vac. In the EU, it is intended to be powered from a Limited Power Source. A limited power source is a certified source of SELV, and if inherently limited, with 8 amps maximum output current, and a maximum of 100VA available; or if not inherently limited, fused with a maximum value of 3.3 Amps, meeting section 2.11 of IEC950, and a maximum of 250VA available.

The power supply can be obtained through Sensormatic or through another source where the provider can furnish the verification. This is required to assure electrical safety in the product.

Stromanforderungen in der EU: Dieses Produkt wird mit 24 V Wechselstrom betrieben. In der EU ist es für den Betrieb durch eine begrenzte Stromquelle vorgesehen. Eine begrenzte Stromquelle ist eine zertifizierte SELV-Quelle (Schutzkleinspannung), bei inhärenter Begrenzung mit einem maximalen Ausgangsstrom von 8 A und 100 VA maximaler Verfügbarkeit, bei nicht inhärenter Begrenzung mit einer maximalen Sicherung von 3,3 A gemäß Abschnitt 2.11 der IEC950 und 250 VA maximaler Verfügbarkeit. Das Netzteil kann über Sensormatic oder eine andere Quelle bezogen werden, wobei der Anbieter den Nachweis der Konformität bereitstellen sollte. Dies ist zur Gewährleistung der elektrischen Sicherheit des Produktes erforderlich.

CAUTION

- Cables:
 - Do not run data and power cables adjacent to or in the same conduit as line voltage mains power.
 - SensorNet 485 networks require 22 AWG unshielded cable. Do not exceed 32 devices per cable run.
 - RS-422 networks require 22 AWG shielded cable. Do not exceed 10 devices per cable run.
 - Manchester networks require 18 AWG shielded cable. Do not exceed 3 devices per cable run.
- I/O PC board:
 - Use a jeweler's 2.5mm (0.1in) slotted screwdriver to tighten connector screws. Do not over tighten these screws.
 - Always terminate I/O board jumper E1 if the dome connects at the end of a cable run.
 - Keep the dust cover to protect contacts should the environmental PC board need to be removed from the housing.
- When connecting the housing and eyeball assembly to an outdoor housing remove both slot covers to keep the camera from overheating.
- If disassembling the dome:
 - Dome contains electrostatic-sensitive devices! Use a ground strap when handling PC boards.
 - Once disassembled, parts of housing and eyeball assembly are fragile and may break. Use extreme care!

Indoor Installation

This section explains how to connect the housing and eyeball assembly to a mounting base.

Items You Will Need

You should have on hand the following tools and parts:

- Install/Removal tool to attach and detach domes and bubbles without a ladder.
- Base kit: ADSDUIOB (black) or ADSDUIOBW (white).
- SpeedDome Ultra 8 housing and eyeball assembly, 0101-0150-xx.

Other Preparations

To ensure a smooth and successful installation, you must:

- Have electrical work comply with latest national electrical code, national fire code, and all applicable local codes and ordinances.
- Coordinate work with other trades to avoid interference.
- Verify existing site conditions and coordinate with the owner's representative and appropriate utilities as required.
- Obtain copies of all related plans, specifications, shop drawings and addenda to schedule and coordinate related work.
- Thoroughly review the project to ensure that all work meets or exceeds the above requirements. Bring alleged discrepancies to the attention of the CCTV Project Coordinator.

Connecting to the Mounting Base



WARNING: Ensure that ac power and electrical signals are off during wire connections!

Referring to Figure 9:

1. Set termination jumper JW1 according to the dome's position in the communications line.

Position of dome in communications line...	Setting	Pins
Between other devices	Unterminated	Off
End of communications line	Terminated	1-2

Note: You may need a small slotted screwdriver to gently pry jumper loose. Be careful not to damage the PC board.

2. Connect the video cable to I/O board BNC video cable extension.
3. Connect Manchester, RS-422, or SensorNet 485 data wires to connector TB1. If using a Pelco Coaxitron or Panasonic UTC protocol, no data wires are connected, just power.

Manchester data connections.

Order data cable 88760 (plenum) or 8760 (non-plenum) from Belden by calling 1-800-235-3361.

Pin	Color	Designation
1-4	—	Not used.
5	Black	Manchester (+)
6	White	Manchester (-)

RS-422 data connections

Pin	Color	Designation
1	Orange	RS-422 Data In High (+)
2	Green	RS-422 Data In Low (-)
3	Yellow	RS-422 Data Out High (+)
4	Brown	RS-422 Data Out Low (-)
5-6	—	Not used.

SensorNet data connections

Pin	Color	Designation
1-4	—	Not used.
5	Orange	SensorNet (unshielded)
6	Yellow	SensorNet (unshielded)

- Connect twisted pair wires, if used, to connector TB5.

Pin	Designation
1	Video
2	Video Ground

Figure 9. Electrical connections

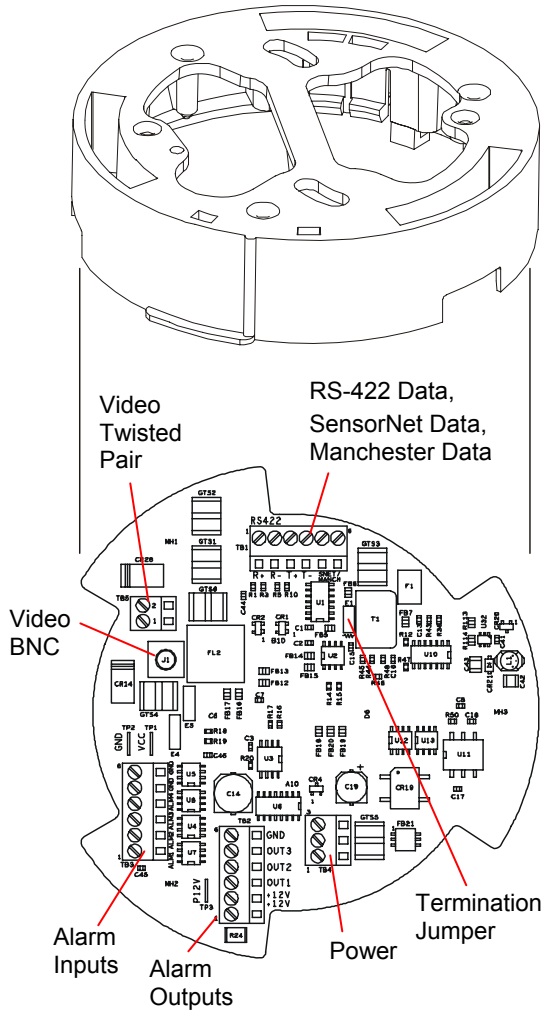

- Connect the alarm output cable, if used, to the TB2 connector.

Pin	Color	Designation
1	—	12Vdc (100mA max.)
2	—	12Vdc (100mA max.)
3	—	Output 1 (40mA sync. max.)
4	—	Output 2 (40mA sync. max.)
5	—	Output 3 (40mA sync. max.)
6	—	Ground

- Connect the alarm input cable, if used, to the TB3 connector.

Pin	Color	Designation
1	—	Alarm 1 input (3.5mA sink)
2	—	Alarm 2 input (3.5mA sink)
3	—	Alarm 3 input (3.5mA sink)
4	—	Alarm 4 input (3.5mA sink)
5	—	Ground
6	—	Ground

- Connect power to the TB4 connector.

Pin	Color	Designation
1	Black	24Vac
2	Red	Ground
3	White	24Vac

- Reattach the I/O board.

- Connect power to the base.

- Check LEDs on the I/O board to verify power and data are reaching the dome (Figure 10).

- The green ac power LED (CR9) glows steadily when ac power is applied.
- For Manchester or SensorNet: The yellow comm. LED (CR11) glows steadily (Manchester) or blinks (SensorNet). If this LED is off, then probably one or both communication wires are open or both are shorted together.

For RS-422: Press and hold data test switch SW1 and observe nearby red (CR12) and green (CR13) LEDs; they indicate the following:

Constant green, Blinking red	RS-422 line correctly wired.
Constant green, Red off	RS-422 "Data In -" shorted to ac ground.
Constant red, Blinking green	"Data In +/ -" wires reversed.
Blinking red, Green off	"Data In +" shorted to ac ground.
Both LEDs off	"Data In +/ -" wires shorted or open.

Figure 10. Test switch/LEDs on I/O board

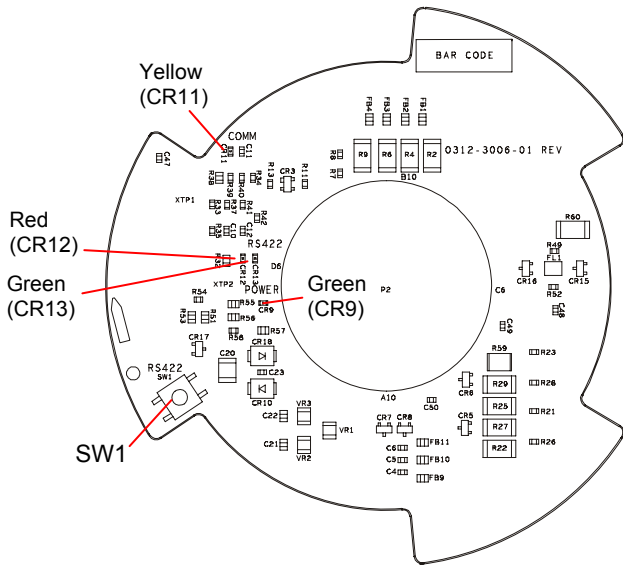

11. Set the dome address (Figure 11).

Figure 11. Setting address switches

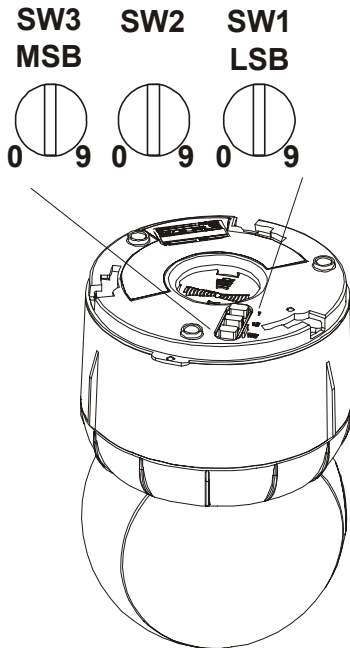

Use the following addresses for the protocols shown:

PROTOCOL	SW3	SW2	SW1
AD Manchester, Range: 001–064	0	x	x
PELCO "P," 4800 baud RS-422, Range: 001–099	0	x	x
Sensormatic, 4800 baud RS-422, Range: 001–063, 065–099	0	x	x
Sensormatic, RS-422 Address 64 is used for global broadcasts	0	6	4
SensorNet, Range: 001–099	0	x	x
VICON, 4800 baud RS-422, Range: 001–099	0	x	x
SensorNet, Range: 100–254	1 2	x x	x x
Address 255 is used for global broadcasts	2	5	5
Dept. of Transportation (NTCIP), 4800 baud RS-422, Range: 301–399	3	x	x
Dept. of Transportation (NTCIP), 9600 baud RS-422, Range: 401–499	4	x	x
Dept. of Transportation (NTCIP), 19.2K baud RS-422, Range: 501–599	5	x	x
PELCO "P," 2400 baud RS-422, Range: 601–699	6	x	x
PELCO "P," 9600 baud RS-422, Range: 701–799	7	x	x
Reset camera block from 38.4K to 4800 baud (SpeedDome Ultra VII WITH EIS 0100+ feature only).	8	3	0
PANASONIC UTC	8	9	0
Tyco UTC	8	9	1
PELCO UTC (Origins, Standard, & Extended)	8	9	3
RS-422, LED diagnostic mode for dome wiring installations without the I/O Board	9	0	0
Manufacturing Use, Range: 901-999	9	x	x

12. Connect the housing and eyeball assembly to the base (Figure 12) by aligning the cap and base tabs, and then turning the housing clockwise until you hear a click.

Note: The base has a florescent arrow and dot. Once the housing is secured, only the florescent dot will be seen.

Note: Tabs on the base and cap have small holes that align once the base and cap are locked. If required, insert the security pin supplied (part number 2869-0037-01) through the holes.

CAUTION: Use of the security pin prevents the use of the install/removal tool.

Figure 12. Connecting housing and eyeball assembly to mounting base

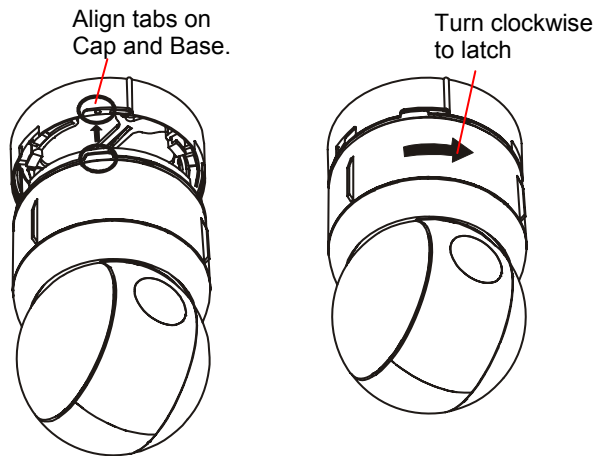

13. Wait a few seconds for dome to begin its homing routine. This routine indicates that the address was placed into the dome memory and that the dome is ready for programming.

Using the Install/Removal Tool

CAUTION: Do not use this tool to connect the dome to the standard base (without I/O board)

CAUTION: Use of the security pin prevents the use of the install/removal tool.

The RHIRT install/removal tool is used only when the dome is connected to a base having an I/O board. The tool eliminates the need for a ladder during routine service. It can be used to:

- Detach the skirt or bubble from the housing, if used. The skirt or bubble remains attached to the housing during service.
- Connect/Disconnect the dome from the base with I/O board.
- Reattach the skirt or bubble.

Telescopic Pole Required to Use Tool

The tool attaches to a telescopic pole used to clean swimming pools. The pole should be approximately 1.7m (5.5ft) telescoping to 4.7m (15.5ft) long. It should have a 29.7mm (1.17in) inside diameter to accept the 28.6mm (1.125in) outside diameter stem of the tool.

Procedure

Referring to Figure 13, maneuver the stem of the tool into the top of the pole until it snaps into place.

TO ATTACH SKIRT OR BUBBLE:

Use the tool to push up on the bubble to secure it in place. Magnets secure the bubble. Lower the pole.

TO DETACH SKIRT OR BUBBLE:

Lifting the pole up at an angle, use one of the hooks on the tool to catch one of the notches at the side of the dome and pull down. The T-lanyard will prevent the skirt or bubble from falling.

TO CONNECT DOME:

1. Insert the dome "eyeball down" into the tool's receptacle. Fins on the dome mate with slots in the tool. Use the fins to properly align the dimple at top of the dome with the label on the tool.
2. Align the label on the tool with the logo on the I/O board in the base. Push the dome up into place.
3. Turn the dome clockwise until it clicks.
4. If power is applied, the dome should begin its "homing" routine.
5. Lower the pole.

TO DISCONNECT DOME:

1. Raise the pole and insert the dome "eyeball down" into the tool's receptacle.
2. Fins on the dome mate with the slots in the tool.
3. Turn the dome counterclockwise until it unlocks.
4. Lower the pole "vertically" to prevent the camera dome from falling out.
CAUTION: Turning the pole horizontally as it is lowered can cause the camera dome to fall out of tool and possibly break on the floor.
5. Remove the dome for service.

Figure 13. How to use the install/removal tool

Skirt or Bubble Attachment/Detachment

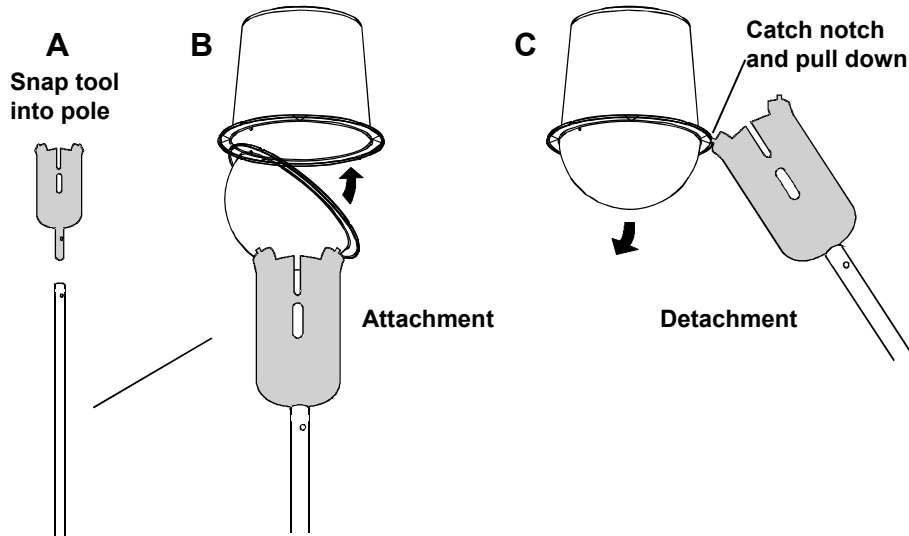

Dome Connection (Reverse the steps to disconnect)

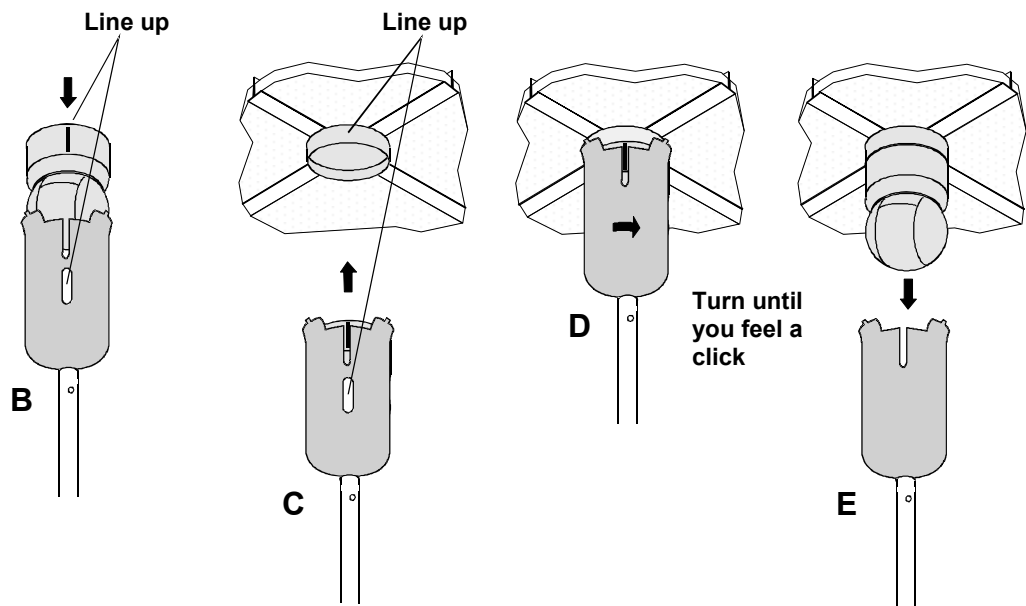

Troubleshooting Indoor Domes

CAUTION: This troubleshooting section is for indoor camera domes only! To troubleshoot outdoor domes, see the installation and service guide shipped with the outdoor housing.

This chapter contains information on:

- Routine troubleshooting
- Detailed troubleshooting
- Disassembling the dome.

IMPORTANT!

1. Try routine troubleshooting first! Use this procedure to isolate the problem without disassembling the housing and eyeball assembly (the I/O board is field repairable).

CAUTION: DO NOT troubleshoot if the dome functions but does not pan or tilt (see step 2).

2. If you cannot isolate the problem or the dome functions but does not pan or tilt, contact your sales representative for repair instructions.
3. If you have no choice but to repair the housing and eyeball assembly. Follow the detailed troubleshooting procedure, but use extreme care.

CAUTION: Once disassembled, parts of the housing and eyeball assembly are "extremely fragile" and may break. Proceed using extreme care!

Items You Will Need

You should have on hand the following items:

- Phillips screwdriver
- Small slotted screwdriver
- 2.5mm (0.1in) slotted screwdriver (for wire connections). Wider blade widths can damage connectors.
- Socket wrench with 127mm (5in) extension and 5.5mm, 6mm, 8mm, and 10mm sockets
- 14-18 AWG and 20-22 AWG wire strippers
- Install/Removal tool to connect/disconnect dome to indoor bases with I/O boards, and to attach/detach skirts and bubbles—without a ladder.

Routine Troubleshooting

Use this procedure if:

- Dome does not respond to commands
- Dome does not produce video
- Quality of the video is poor
- Dome has no lens control.

CAUTION:

- DO NOT use this procedure if the dome functions but does not pan or tilt (see step 2 on page 16).
- Use a ground strap when handling the I/O board. When shipping the base and I/O board assembly, place the dust cover over the spring finger connector to protect it.
- DO NOT over tighten connector screws on the I/O board; they are delicate. Use a 2.5mm (0.1in) slotted screwdriver. Wider blade widths can damage connectors.

Procedure

Follow steps until the problem is corrected.

1. Check video on monitor (a, b, or c).
 - a. No video? Go to step 2.
 - b. Contrast or color off?
YES Contact your sales representative for repair instructions.
NO Go to step 2.
 - c. Video rolls when switching between monitors?
YES Use the video controller or switcher to synchronize video vertical sync phases of all domes to ac line. For specific instructions, see the installation and service guide for the controller or switcher.
NO Go to step 2.
2. Check ac power and video connections at J-box. Are 24Vac and/or video signal absent?
YES Correct problem at J-box.
NO Go to step 3.

3. Detach the dome from its base. Are the address switches set correctly?

YES If dome still doesn't respond, contact your sales representative for repair instructions. If you must repair the dome, see **Detailed Troubleshooting** on page 18.

NO Set correct address and reattach housing and eyeball assembly.

4. Isolate the problem to the housing/eyeball assembly or base by attaching dome to another base. Does dome display video or respond to commands?

YES Problem is likely cable connections or the I/O board, if used. Go to step 5.

NO Contact your sales representative for repair instructions

5. Verify the video cable is securely connected to coax of I/O board (Figure 14). Is the cable disconnected?

YES Connect cable.

NO Go to step 6.

6. Observe the green power LED CR9 on the I/O board (Figure 15). Is the LED off or not on steady?

YES Verify the 24Vac cable is properly attached. If so, replace the I/O board or contact your sales representative for repair instructions.

NO Go to step 7.

P7 Connector (AC in)

Pin	Color	Designation
1	Black	24Vac
2	Red	Ground
3	White	24Vac

7. Observe the yellow comm. LED CR11 on the I/O board (Figure 15). Is the LED on or flashing?

YES Go to step 8.

NO Verify the cable is properly attached by referring to table in step 9, page 18. If so, replace the I/O board or contact your sales representative for repair instructions.

Figure 14. I/O board connector and jumper locations

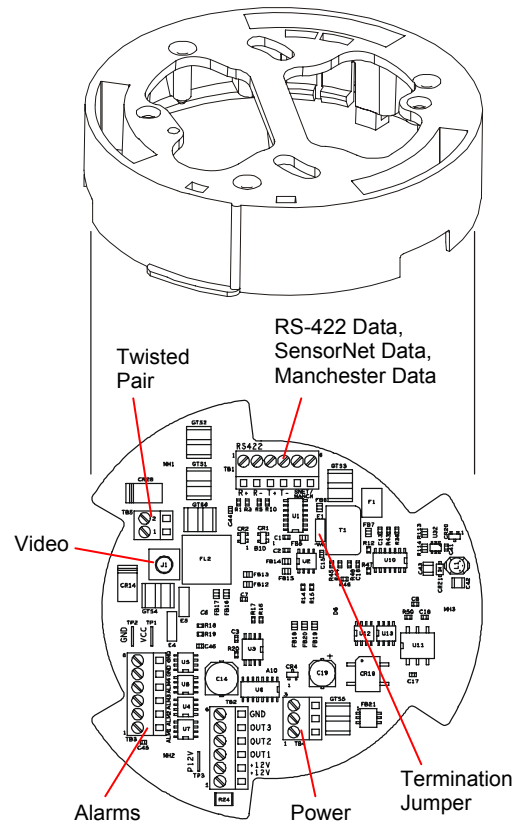

P1 connector (Manchester data)

Pin	Color	Designation
1-4		Not used.
5	Black	Manchester (+)
6	White	Manchester (-)

P1 connector (RS-422 data)

Pin	Color	Designation
1	Orange	RS-422 Data In High (+)
2	Green	RS-422 Data In Low (-)
3	Yellow	RS-422 Data Out High (+)
4	Brown	RS-422 Data Out Low (-)
5-6	—	Not used.

P1 connector (SensorNet 485 data)

Pin	Color	Designation
1-4	—	Not used.
5	Orange	SensorNet 485
6	Yellow	SensorNet 485

8. If using RS-422 network and an I/O board is used, check comm. line connections by pressing and holding data test switch SW1 (Figure 15) and observing nearby red (CR12) and green (CR13) LEDs. These LEDs indicate the following:

<i>Constant green, Blinking red</i>	Comm. line correctly wired.
<i>Constant green, Red off</i>	"Data In -" shorted to ground.
<i>Constant red, Blinking green</i>	"Data In +/" wires reversed.
<i>Blinking red, Green off</i>	"Data In +" shorted to ground.
<i>Both LEDs off</i>	"Data In +/" wires shorted or open.

9. Check the spring finger connector on the I/O board by connecting a known good dome to the base to verify contact between the spring fingers and the CPU board (under cap). Does dome produce video and respond to commands?

YES Spring fingers may not have seated properly. Reconnect housing and eyeball assembly.

NO Replace I/O board.

If routine troubleshooting did not solve the problem, the manufacturer strongly recommends that you contact your sales representative for repair instructions.

If you must perform detailed troubleshooting, use extreme care when disassembling parts! See Detailed Troubleshooting, next.

Figure 15. I/O board test switch and LED locations

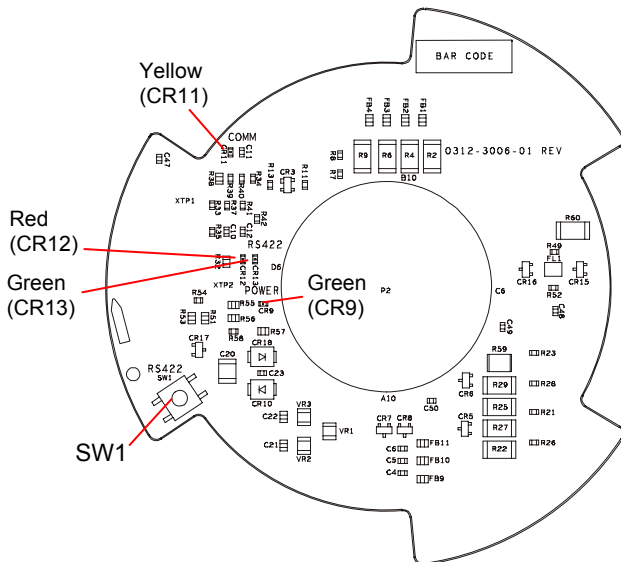

Detailed Troubleshooting

Use this procedure to determine if the problem is a simple cable connection or a major component.

To perform this procedure, you must open the housing and eyeball assembly. Refer to "Disassembling the Dome" on page 19.

CAUTION:

- DO NOT use this procedure if the dome functions but does not pan or tilt (see step 2 on page 16).
- If routine troubleshooting did not solve the problem, the manufacturer strongly recommends that you contact your sales representative for repair instructions. If you must perform detailed troubleshooting, use extreme care when disassembling parts!
- When shipping a base and I/O board assembly, use a dust cover to protect the spring fingers.
- Connector screws on the I/O board are delicate. DO NOT over tighten them! Use a 2.5mm (0.1in) slotted screwdriver. Wider blade widths can damage connectors.
- The dome contains electrostatic-sensitive PC boards. Use a ground strap when handling these boards.

Procedure

Choose a, b, c, d or e to determine if the problem is a cable connection or major component.

a. Dome functions but does not pan.

On the power supply board, is the pan motor ribbon cable attached to connector P2 and is the metal side of its fingers towards the contacts of connector?

YES Replace the power supply board. If this doesn't work, replace the pan motor.

NO Connect the cable(s).

b. Dome functions but does not tilt.

On the camera/lens board, is the tilt motor cable attached to connector P3?

YES Replace the camera/lens board. If this doesn't work, replace the tilt motor or power supply board.

NO Connect the cable(s).

c. Dome pans to the home position but does not tilt or display video.

On the power supply board, is the slip ring cable attached to connector P1?

YES Replace the Camera/Lens board.

NO Connect the cable.

d. Dome does not "home" or respond to commands even when attached to another dome's base and its address switches are set correctly (dead dome).

Is the slip ring cable attached to connector P1?

YES Replace the CPU board. If this doesn't work, replace the power supply board.

NO Connect the cable(s).

e. Dome functions but does not find the pan home position.

On the bottom of the power supply board, check that the optical sensor is functioning and plugged into connector P3 on the power supply board.

Disassembling the Dome

CAUTION: Once disassembled, parts of dome housing and eyeball assembly are "extremely fragile" and may break. Use extreme care!

This section explains how to remove the following parts from the camera dome.

- CPU board, page 20
- Power supply, page 20
- Pan motor, page 21
- Slot covers, page 21
- Camera, page 22
- Eyeball, page 22
- Camera/Lens board, page 23
- Tilt motor, page 24.

To order parts (authorized users only), see page 25.

Tools Required

- Phillips screwdriver.
- Small slotted screwdriver.

Removing the CPU Board

CAUTION: Electrostatic-sensitive device. Use a ground strap when handling CPU board.

Referring to Figure 16.

1. Remove cap.

Remove the three Phillips screws holding the cap, then "gently" lift the cap (this will unplug the CPU board from the power supply).

2. Remove CPU board.

Remove the two screws holding the board in the end cap. Then push your finger through large finger connector hole in the cap to pop out the board.

3. Reverse the steps to reassemble.

Figure 16. Removing the CPU board

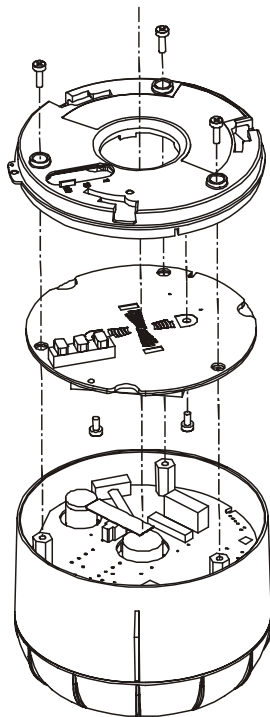

Removing the P/S Board

CAUTION: Electrostatic-sensitive device. Use a ground strap when handling power supply board.

Referring to Figure 17.

1. Remove three Phillips screws holding the cap, then "gently" lift the cap (this will unplug the CPU board from the power supply).

2. On the power supply board, detach 14-pin slip ring cable from connector P1 and pan motor flat flex cable from connector P2.

3. Carefully lift the power supply board and tilt it to the edge to remove the 4-pin optical sensor cable P3 on the bottom of the board.

4. Remove the power supply board.

5. Remove three standoffs. Then remove the power supply board from the housing.

6. Reverse the steps to reassemble.

Figure 17. Removing the P/S board

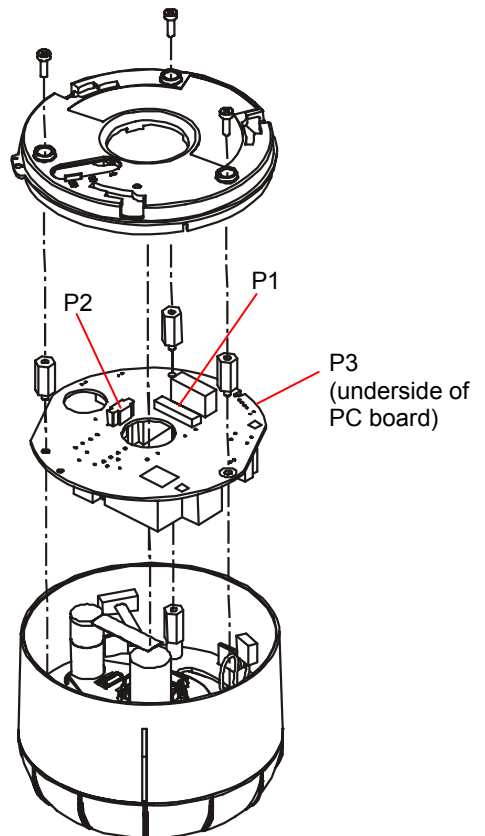

Removing the Pan Motor

Referring to Figure 18.

1. Perform procedure "Removing the P/S Board" (page 20).
2. Remove pan motor.
 - a. Lift the motor housing up as shown to disengage the motor from the pan gear.
 - b. Then pull the motor bracket towards the outside of the housing to remove it.
3. Reverse the steps to reassemble.

CAUTION: When putting in a new motor, be careful to properly mesh motor and pan gears! Failure to do so can destroy both motor and pan gear. Verify pan gear turns freely!

Figure 18. Removing the pan motor

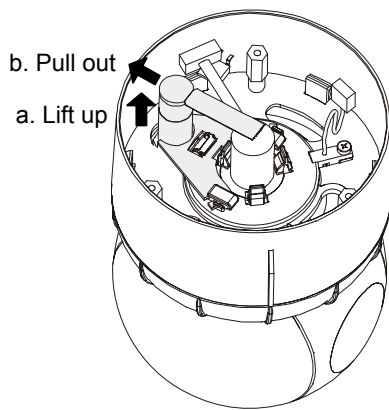

Removing the Slot Covers

1. Gently swivel eyeball to totally expose one of two slot covers (Figure 19).

CAUTION: Swiveling fast can damage gears.

2. Insert small, thin-bladed screwdriver into space between cover and eyeball.
3. Gently pry off slot cover.
4. Gently swivel eyeball to totally expose remaining slot cover. With other cover removed, this cover can be easily removed.

Figure 19. Removing slot covers

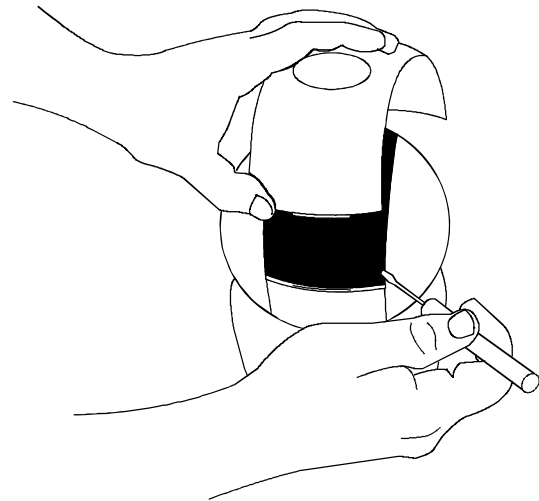

Removing the Camera

1. Perform procedure "Removing the Slot Covers" (page 21).
2. Remove ribbon cable from camera (Figure 20).
Swivel camera yoke to expose camera connector. Then, using a small slotted screwdriver, 1) gently pry camera connector loose from camera, and 2) pull it down through cable tie wrap.

Figure 20. Removing the ribbon cable

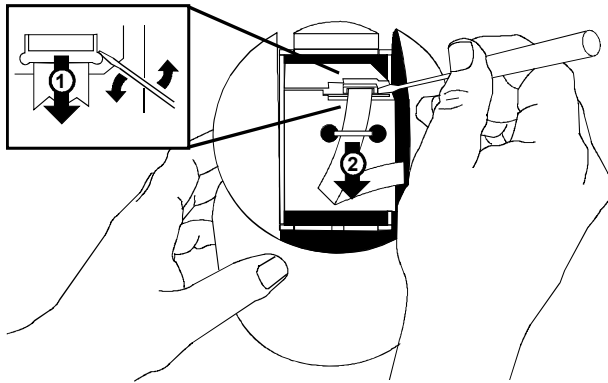

3. Remove camera (Figure 21).
1) Loosen the screw holding the camera tripod mount and then 2) carefully lift the camera out.

Figure 21. Removing the camera

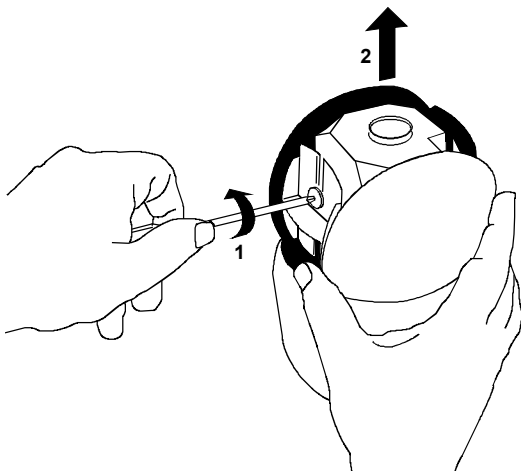

4. Reverse the steps to reassemble. Ensure ribbon cable pins are inserted "face down".

Detaching the Eyeball

1. Perform procedure "Removing the Slot Covers" (page 21).
2. Perform procedure "Removing the Camera" (this page).
3. Detach the eyeball from the housing (Figure 22).
 - a. Turn the yoke to access the tabs. One tab is more accessible than the other. Use your finger to press this tab while using a small slotted screwdriver to press the other tab.
 - b. While pressing both tabs, push up on eyeball to detach it.

Figure 22. Loosening the eyeball

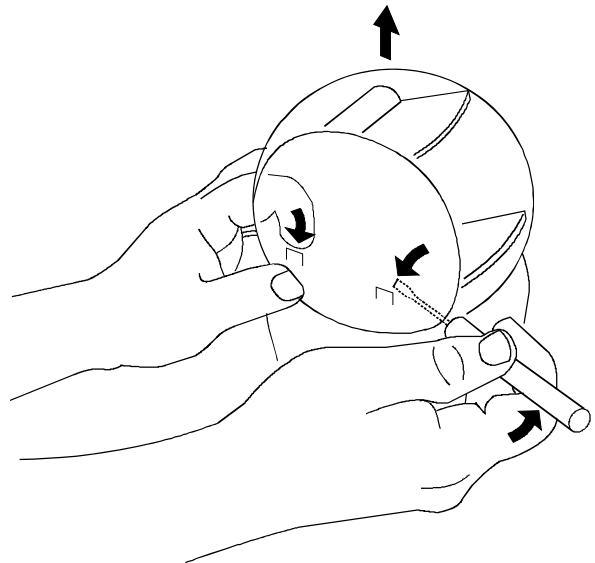

4. Detach slip ring connector (Figure 23).

Figure 23. Detaching the eyeball

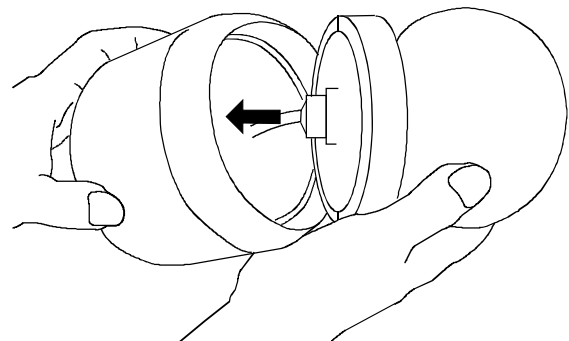

Removing the Camera/Lens Board

1. Perform procedure "Removing the Slot Covers" (page 21).
2. Perform procedure "Removing the Camera" (page 22).
3. Perform procedure "Detaching the Eyeball" (page 22).
4. Separate the yoke brackets (Figure 24).

Figure 24. Separating the yoke brackets

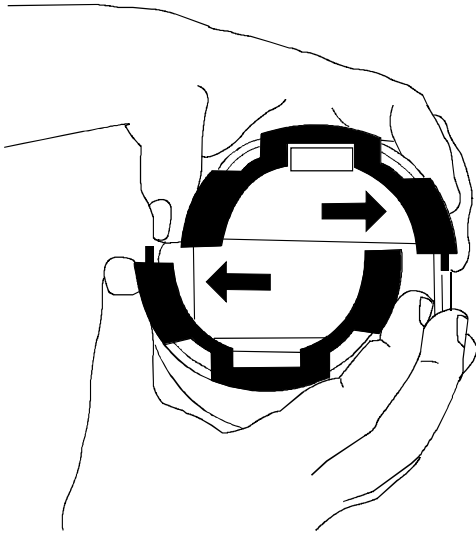

5. Gently pry off the yoke bracket covering the camera/lens board to access the bearing assembly (Figure 25).

Figure 25. Removing the yoke brackets

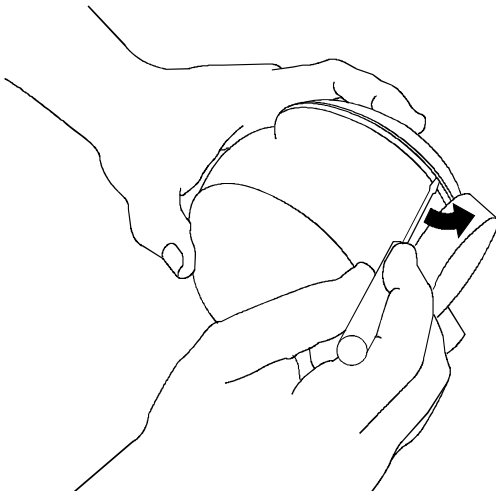

The following steps refer to Figure 26.

6. Access camera/lens board.
To do this, loosen captive retaining screw holding bearing assembly in place and remove this assembly.
7. Remove cables from camera/lens board.
 - a. Small amber ribbon cable is from tilt motor. Unplug this cable from connector J3 on camera/lens board.
 - b. Large gray ribbon cable is from slip ring connector. Unplug this cable from connector J2 on camera/lens board.

DO NOT unplug small white ribbon cable from connector J1.
8. Push out on the three prongs to detach the camera/lens board.
9. Reverse the steps to reassemble.

Figure 26. Removing the camera/lens board

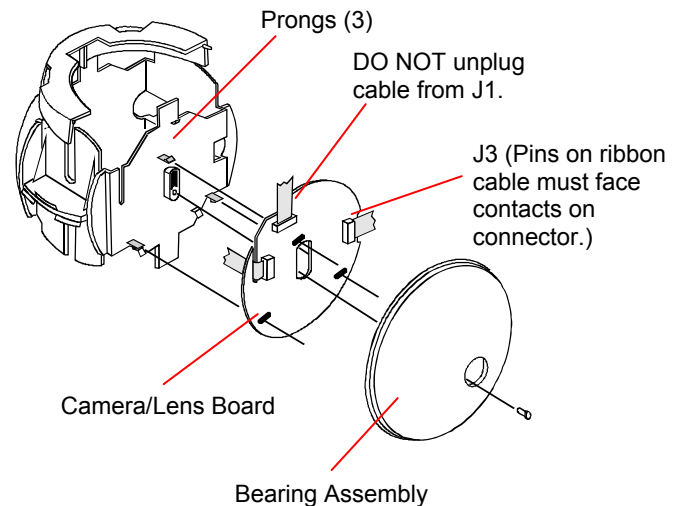

Removing the Tilt Motor

1. Perform procedure "Removing the Slot Covers" (page 21).
2. Perform procedure "Removing the Camera" (page 22).
3. Perform procedure "Detaching the Eyeball" (page 22).
4. Separate the yoke brackets (Figure 27).

Figure 27. Separating the yoke brackets

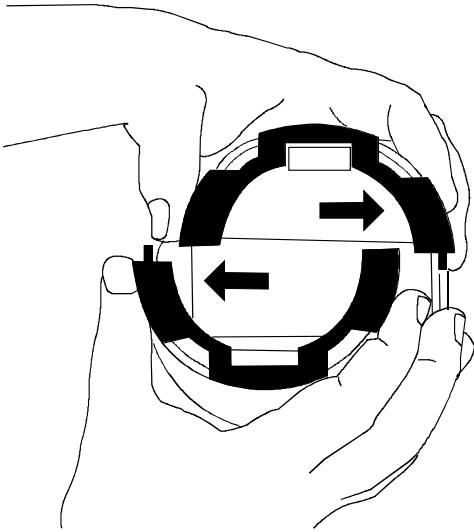

5. Gently pry off the yoke bracket covering the pan gear assembly to access the tilt cable assembly (Figure 28).

Figure 28. Removing the yoke brackets

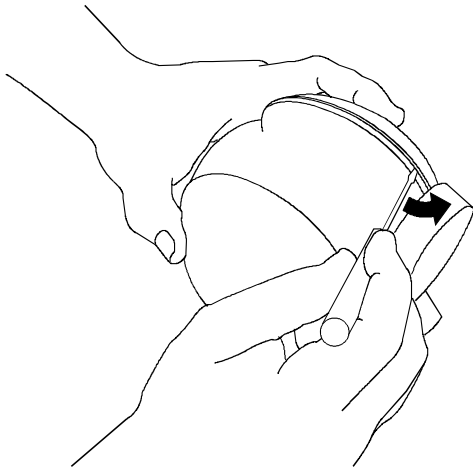

6. Access the tilt motor.

To do this, loosen the captive retaining screw holding the tilt cable assembly in place and gently remove the assembly.

7. Remove the tilt motor (Figure 29).

Lift the motor housing up as shown to disengage the motor from the tilt gear. Then pull the motor bracket towards the outside of the cable/tilt assembly to remove the motor.

Figure 29. Removing the tilt motor

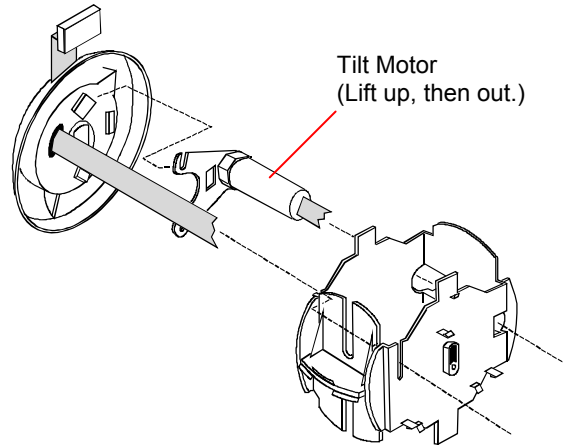

8. Reverse the steps to reassemble.

CAUTION: When installing a new motor, be careful to properly mesh the motor with the tilt gears! Failure to do so can destroy both motor and tilt gear. Verify the tilt gear turns freely.

Parts List for Authorized Users

The following parts can be ordered by authorized users only. To become authorized, contact your sales representative. Parts in the tables below are shown in Figure 30.

Parts lists

Base Assembly with I/O Board

Key	Description	Part Number
1	Mounting Base	0500-7257-02/03
2	I/O Board, Indoor	0312-3006-01
3	Dust Cover	3100-0066-01
4	Video XCVR BNC	ADACTP01BNC

Housing Assembly

Key	Description	Part Number
5	Screws, M3x10 PHP (Qty. 3†)	5801-1061-120
6	Cap	0505-1224-01/02
7	CPU PC Board	0312-2104-01
8	Screw, M3x6, PHP (Qty. 2†)	5801-1041-120
9	Standoff, M3x16 LG SS (Qty. 3†)	5899-0055-03
10	Power Supply PC Board	0312-2122-01
11	Pan Motor	3501-0017-01
12	Screw, M3x6, PHP	5801-1041-120
13	Optical Sensor	6003-0228-01
14	Slip Ring Assy.	2100-0005-02
15	Standoff, M3x16 LG SS (Qty. 3†)	5899-0055-03
16	Housing	0500-7255-02/03
17	Bearing Assy., Pan Gear	2510-0040-01
18	Trim Ring	0505-1281-01/02

Eyeball Assembly

Key	Description	Part Number
19	Cable Assy., Tilt	0650-1680-01
20	Tilt Motor	3501-0018-01
21	Yoke, Camera	0500-7258-01
22	Slot Cover (No Lens)*	0500-8037-01/-02
23	Camera/Lens PC Board	0312-0953-01
24	Bearing Assy., Lens Carriage	2510-0038-01
25	Yoke Bracket (Qty. 2†)	0500-8038-01/-02
26	Camera, Color, 22x, NTSC	2003-0037-41
27	Camera, Color, 22x, PAL	2003-0037-42
28	Camera, Color, 35x, Day/Night, NTSC	2003-0054-01
29	Camera, Color, 35x, Day/Night, PAL	2003-0054-02
30	Screw, 1/4-20 x 1/2 (Qty. 2)	2804-7106-07
31	Washer, Locking (Qty. 2)	2847-0101-10
32	Washer, Flat (Qty. 2)	2848-8100-08
33	Screw, M2x3 (Qty. 4†)	5801-0011-120
34	Screw, M2x3 (Qty. 2†)	5801-0011-120
35	Tripod Mount	0500-6712-01
36	Camera Support	0500-9680-01
37	Slot Cover with Lens*	0404-0353-01/-02

* Items 22 and 37 are supplied with the final assembly, not the eyeball assembly.

† Item shipped in quantities of one. Order the quantity required.

Figure 30. Base, housing, and eyeball assembly

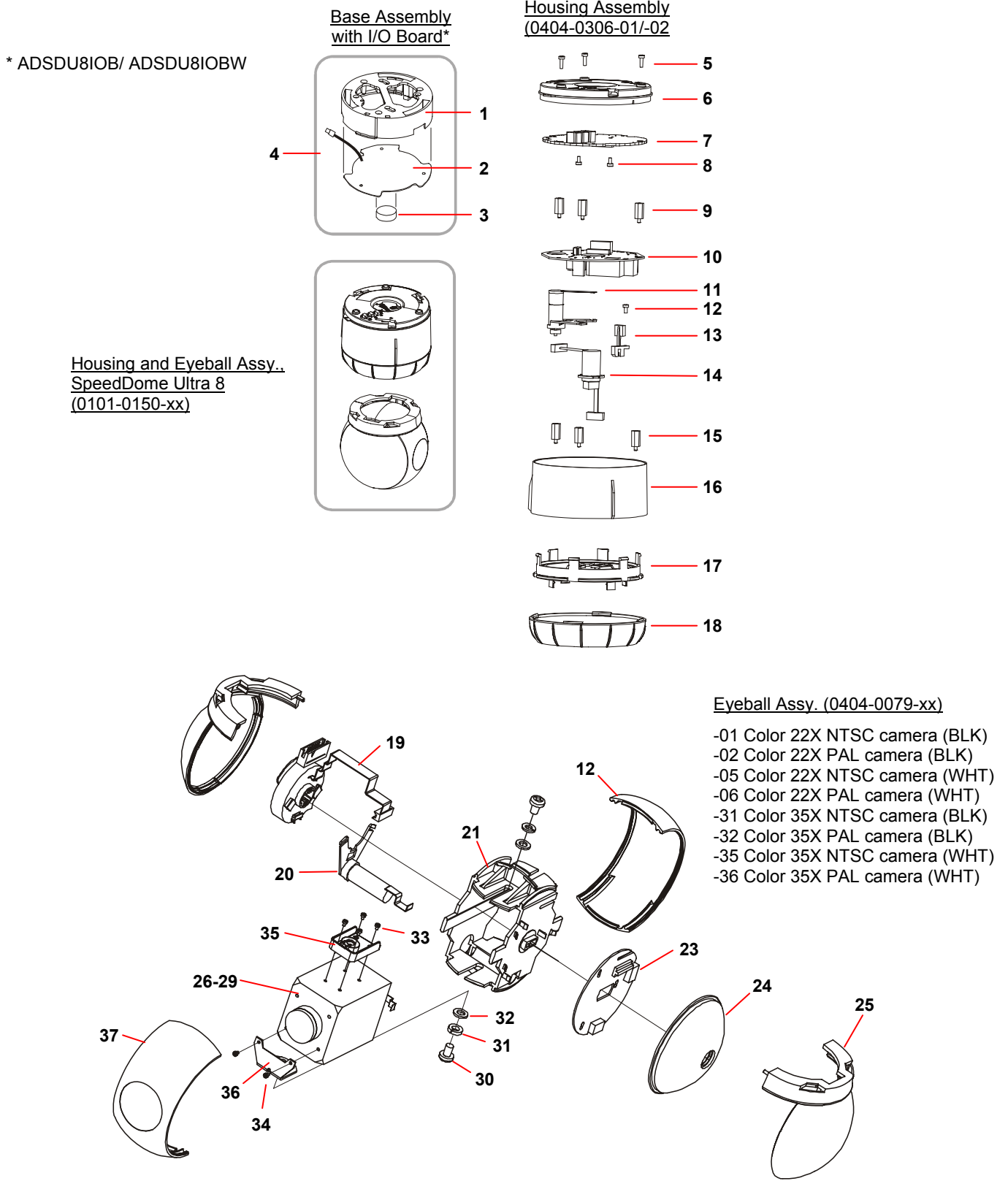

Specifications-Indoor Dome

Operational

Pan/Tilt:

Manual pan speed	0.25°-100° per second (scaled to zoom position)
Manual tilt speed	0.25°-100° per second (scaled to zoom position)
Preset pan speed:	360° per second maximum
Preset tilt speed	220° per second maximum
Pan travel	360° continuous rotation
Tilt travel	110°
Pan/Tilt accuracy	±0.5°

Auto synchronization:

Line locked	Remote V-phase adjustment
Internal	Built-in sync generator
Up-the-coax	System sync
Address range	1-99 (RS-422/RS-485), 1-64 (Manchester), 1-255 (SensorNet) AD-UTC (based on number of inputs)
Preset access time	<1 second to position. Full zoom in <4 seconds. Focus on dome saved presets in <1 second. Focus on controller saved presets in <7 seconds
Programmable patterns	Up to 16 depending on host
Program storage	2 Mbytes of Flash memory
Data storage	256 Kbytes of SRAM
Menu languages	English, French, German, Spanish, Italian, and Portuguese

Electrical

Input voltage	18-30Vac, 50/60 Hz NEC Class 2, LPS
Design tolerance	16-36Vac, 50/60Hz
Power consumption	11W max.
Current	0.77A @ 16Vac
Power on in-rush current	1.5A
Allowable drop out	100ms

Surge Protection:

Video output	Low capacitance Zener suppressor 6.5V, 1500W
Power line	TVS rated at 60V, 1.5 joules, 250A 8/20µs impulse

RS-422

TVS rated at 9.8V/1A, 20V/25A, 500W, 8/20µs impulse

Manchester/
SensorNet 485

Gas discharge tube rated at: 8/20µs impulse discharge current of 10kA, ten 8/20µs impulse discharge current of 5kA Isolation transformer coupled 2000Vrms. PTC fuse protects transformer. TVS rated at 9.8V/1A, 20V/25A, 500W, 8/20µs impulse

Alarm input

TVS rated at 9.8V/1A, 20V/25A, 500W, 8/20µs impulse

Alarms Inputs/Control Outputs:

Inputs	4 opto-isolated; requires 3.5mA sink to ground
Outputs	3 open collector drivers @ 30Vdc, 40mA

Environmental

Operating temperature	-10° to 50°C (14° to 122°F)
Relative humidity	0 to 95% non-condensing
Storage temperature	-20°C to 65°C (-4°F to 149°F)

Mechanical

Height (TBD)	205mm (8in)
Eyeball diameter	120mm (4.7in)
Weight:	
Housing and eyeball	1.09kg (2.4 lbs)
Base (with I/O board)	0.16kg (0.35 lbs)

Lens and Bubble Densities

Eyeball Lens	f0
Bubbles:	
RUCLR (Clear)	f0
RUSLV (Silver)	f1.5 to f2
RUSMK (Smoke)	f0.5
RUGLD (Gold)	f1.5 to f2

22X Camera

Type..... Interline transfer 1/4in CCD array
Scanning area 3.2 (H) x 2.4 (V) mm
Scanning system 2:1 interlace
Horizontal resolution 470 lines at center
Video out 1.0 Vp-p/75 ohms composite
Signal-to-noise..... 50dB (typical)
Minimum illumination 0.3 lux (AGC On, 20 IRE)
0.02 lux with ¼ sec open shutter
White balance Through-the-Lens (TTL), Automatic
Tracing White balance (ATW)

NTSC:

Pickup device 768 (H) x 494 (V) pixels
Scanning 525 lines, 60 fields, 30 frames
Horizontal 15.734kHz
Vertical 59.9Hz

PAL:

Pickup device 752 (H) x 582 (V) pixels
Scanning 625 lines, 50 fields, 25 frames
Horizontal 15.625kHz
Vertical 50Hz

Lens Design:

Type Aspherical
Focal length 4 to 88mm
Aperture f1.6 (wide angle), f3.8 (telephoto)

Viewing angle (equivalent to 8mm to 80mm on ½-inch
CCD array or 11mm to 110mm on 2/3-inch CCD array):

4mm 47.0°(H) x 35.2°(V)
88mm 2.2°(H) x 1.6°(V)

Total zoom 242X

Optical zoom 22X

Digital zoom 11X

Zoom pause 33X default; 22X selectable

Zoom stop 44X, 66X, 88X (default),
110X, 132X, 154X,
198X, 220X, 242X

Zoom/Focus accuracy ±0.5%

35X Day/Night Camera

Type Interline transfer 1/4in CCD array
Scanning area 3.2 (H) x 2.4 (V) mm
Scanning system 2:1 interlace
Horizontal resolution 540 lines at center
Video out 1.0 Vp-p/75 ohms composite
Signal-to-noise 50dB (typical)
Minimum illumination 0.24 lux (AGC On, 20 IRE)
0.028 lux with ¼ sec open shutter
0.021 lux in IR mode
0.00041 lux in IR mode with ½ sec open shutter

White balance Through-the-Lens (TTL), Automatic
Tracing White balance (ATW)

NTSC:

Pickup device 768 (H) x 494 (V) pixels
Scanning 525 lines, 60 fields, 30 frames
Horizontal 15.734kHz
Vertical 59.9Hz

PAL:

Pickup device 752 (H) x 582 (V) pixels
Scanning 625 lines, 50 fields, 25 frames
Horizontal 15.625kHz
Vertical 50Hz

Lens Design:

Type Aspherical
Focal length 3.4 to 119mm
Aperture f1.4 (wide angle), f3.4 (telephoto)

Viewing angle:

3.4mm 55.8°(H) x 41.8°(V)
119mm 1.7°(H) x 1.3°(V)

Total zoom 420X

Optical zoom 35X

Digital zoom 12X

Zoom pause 52X default; 35X selectable

Zoom stop 71X, 94X, 117X, 140X (default)
163X, 186X, 209X, 232X, 255X,
278X, 301X, 324X, 347X, 370X,
393X, 420X

Zoom/Focus accuracy ±0.5%

Field-of-View Formulas:

$$\frac{3.2\text{mm} \times \text{distance from camera (m)}}{\text{Focal length (mm)} \times \text{Digital Zoom}} = \text{Horizontal view (m)}$$

$$\frac{2.4\text{mm} \times \text{distance from camera (m)}}{\text{Focal length (mm)} \times \text{Digital Zoom}} = \text{Vertical view (m)}$$

* Horizontal scanning area of pickup device (mm) in camera.

** Vertical scanning area of pickup device (mm) in camera.

Example: Wide angle view with lens at 6mm and viewed object at 10m.

$$\frac{3.2\text{mm} \times 10\text{m}}{6\text{mm}} = 5.33\text{m Horizontal view (m)}$$

$$\frac{2.4\text{mm} \times 10\text{m}}{6\text{mm}} = 4.0\text{m Vertical view (m)}$$

Declarations

Regulatory Compliance

REG ID	VP SDU
Emissions	47 CFR, Part 15, Class A ICES-003 Class A EN55022 Class A EN61000-3-2 EN61000-3-3
Immunity	EN50130-4
Safety	UL1950 CSA C22.2 No. 950 EN 60950-1

FCC COMPLIANCE: This equipment complies with Part 15 of the FCC rules for intentional radiators and Class A digital devices when installed and used in accordance with the instruction manual. Following these rules provides reasonable protection against harmful interference from equipment operated in a commercial area. This equipment should not be installed in a residential area as it can radiate radio frequency energy that could interfere with radio communications, a situation the user would have to fix at their own expense.

EQUIPMENT MODIFICATION CAUTION: Equipment changes or modifications not expressly approved by Sensormatic Electronics Corporation, the party responsible for FCC compliance, could void the user's authority to operate the equipment and could create a hazardous condition.

Other Declarations

Thank you for using American Dynamics products. We support our products through an extensive and worldwide network of dealers. The dealer, through whom you originally purchased this product, is your point of contact if you have a need for service or support. Our dealers are fully empowered to provide the very best in customer service and support. Dealers should contact American Dynamics at (800) 507-6268 or (561) 912-6259 or on the web at www.americandynamics.net.

WARRANTY DISCLAIMER: Sensormatic Electronics Corporation makes no representation or warranty with respect to the contents hereof and specifically disclaims any implied warranties of merchantability or fitness for any particular purpose.

NOTICE: The information in this manual was current when published. The manufacturer reserves the right to revise and improve its products. All specifications are therefore subject to change without notice.

LIMITED RIGHTS NOTICE: For units of the Department of Defense, all documentation and manuals were developed at private expense and no part of it was developed using Government Funds. The restrictions governing the use and disclosure of technical data marked with this legend are set forth in the definition of "limited rights" in paragraph (a) (15) of the clause of DFARS 252.227.7013. Unpublished - rights reserved under the Copyright Laws of the United States.

TRADEMARK NOTICE: *American Dynamics* and *Sensormatic* are trademarks or registered trademarks of Sensormatic Electronics Corporation. Other product names mentioned herein may be trademarks or registered trademarks of Sensormatic or other companies.

COPYRIGHT: Under copyright laws, the contents of this manual may not be copied, photocopied, reproduced, translated or reduced to any electronic medium or machine-readable form, in whole or in part, without prior written consent of Sensormatic Electronics.

MDR 01/2007

www.americandynamics.net

Appendix A: Vicon Wiring Configurations

In Vicon systems where domes support loop through, daisy chain the SpeedDome Ultra 8 domes off the last Vicon dome in the communications chain.

Figure 31. SpeedDome Ultra 8 dome loop-through wiring from Vicon dome

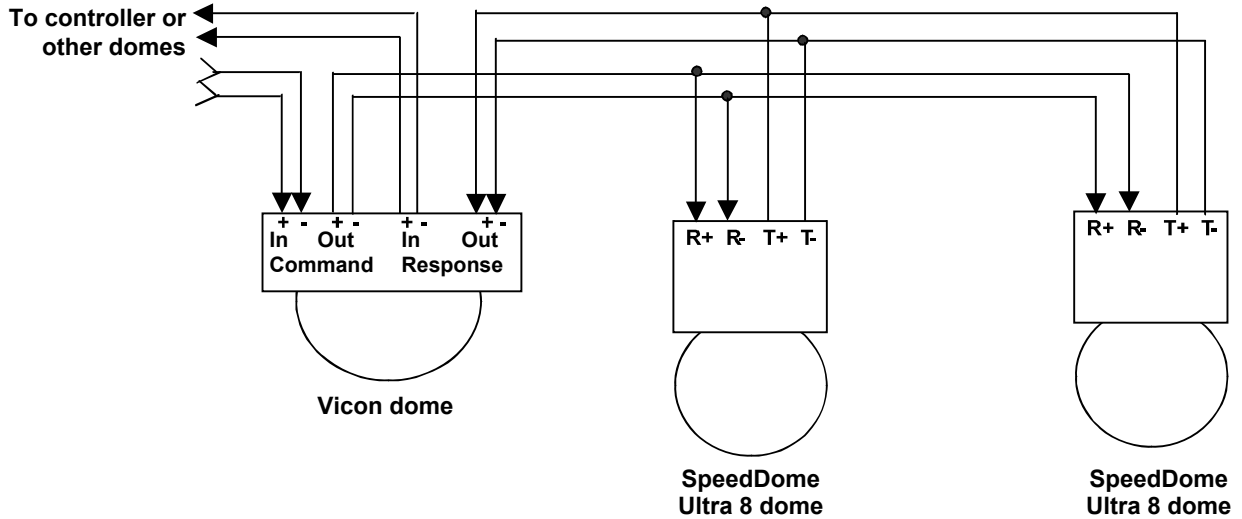

In Vicon systems where domes support RS-485 daisy chaining, daisy chain the SpeedDome Ultra 8 domes off the controller or one of the Vicon domes in the communications chain.

Figure 32. SpeedDome Ultra 8 dome RS-485 wiring from Vicon dome

